

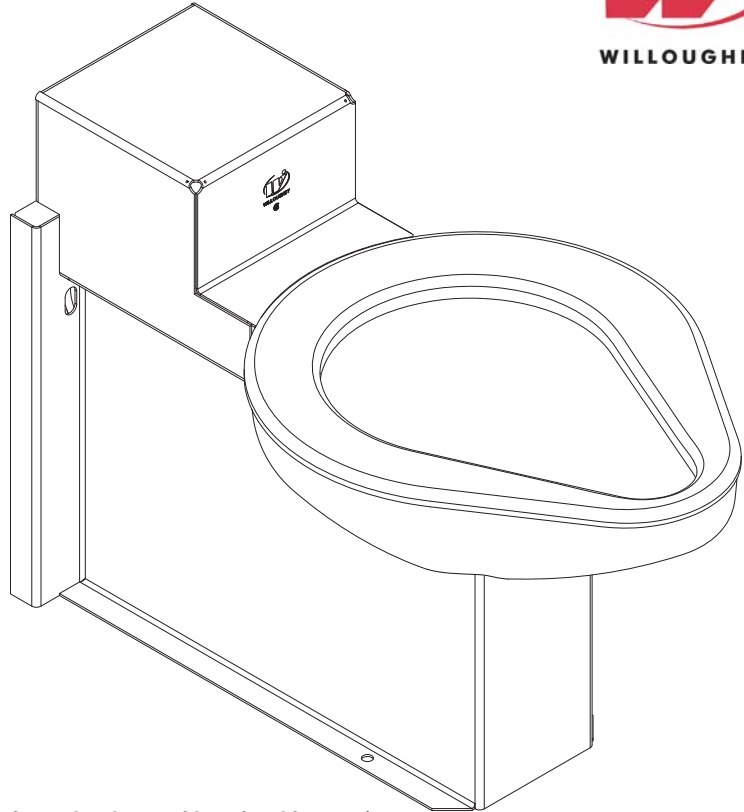

## ETW-1490-FM-RPF Replacement Floor Mounted Wall Outlet Blowout Series Toilet



### Recommended Specifications

*(Unit may be shown with optional features)*

Replacement, Floor Mounted, Wall Outlet, Blowout Series Toilet shall be: Willoughby Model No. **ETW-1490-FM-RPF**

Fixture shall be fabricated from 14 GA, Type 304 stainless steel. The construction shall be an all welded, with exposed stainless surfaces polished to a #3 satin finish.

Standard toilet shall include: elongated toilet bowl with contoured seat, integral crevice-free self-draining flushing rim with positive afterfill and fully enclosed 2-3/8" O.D. trap which shall maintain a minimum 2" seal and pass a 2" ball. Toilet shall be blowout type which requires 35 psi minimum flushing pressure.

Fixture shall withstand loadings up to 2,000 lbs. with no measurable deflection and loadings up to 5,000 lbs. with no permanent damage.

Anchoring shall be through the front and through the floor (anchoring hardware provided by others). Back spud unit shall require chase area for installation and maintenance.

**Note:** Unit will pass a 2" ball.

**Note:** Fixture should only be used with a listed high-efficiency flushometer to ensure the complete system meets the requirements of WaterSense.

*On back to back fixture installations, do not use standard cross type waste fittings: cross flow may result due to blowout jet action. Use sanitary or offset type waste fittings.*

✓	MANUFACTURER	MODEL #	A	B	C	D
	KOHLER	4480ER	11"	5-1/2"	9"	6-1/2"
	AMERICAN STANDARD	2516.037	10-1/4"	6"	10"	6-3/4"
	SUPER SECUR	A-100	10-1/4"	6-1/4"	10"	6-3/4"
	ELJER	111-0580	10"	6"	10"	6-3/4"
	CRANE	3-487	11"	5-1/2"	S	S

S = SPECIFY



**WARNING:** Cancer and Reproductive Harm

- [www.P65Warnings.ca.gov](http://www.P65Warnings.ca.gov)

visit our website at [www.willoughby-ind.com](http://www.willoughby-ind.com)  
5105 West 78th Street • Indianapolis, IN. 46268  
(317) 875-0830 • Fax: (317) 875-0837 • (800) 428-4065



MADE IN THE U.S.A.

# MODEL NUMBER AND OPTIONS:

**1.) Base Model Number:**

- ETW-1490-FM-RPF Replacement, Floor Mounted, Wall Outlet, Blowout Series Toilet

**2.) Inlet Location:**

- BS Back Spud
- TS Top Spud

**3.) Toilet Waste:**

- GWC Gasketed Waste Connection (Standard)

**4.) Flush Valve:**

- FV Hydraulic Flush Valve (Includes Actuator)
  - 1.28 GPF HET (4.8 Lpf)     1.6 GPF ULF (6.0 Lpf)
  - 3.5 GPF (13.2 Lpf)
- EFVP Electronic Flush Valve w/ (PZPB) Ligature-resistant Piezo Push Button (Pick Control)\*\*
  - 1.28 GPF HET (4.8 Lpf)     1.6 GPF ULF (6.0 Lpf)
  - 3.5 GPF (13.2 Lpf)
- NFV Flush Valve Provided by Others

**5.) Other Options:**

- T4 Manual Reset Toilet Overflow Preventer, Requires: (FV) Hydraulic Flush Valve and Accessible Chase
- ET4 Electronic Toilet Overflow Preventer\*, Requires (EFVP), Accessible Chase, & (WUCC-3010) or (WMSII) control
- FVT Flush Valve Connection (Back Spud Only)
- ASFVC Flush Valve Cover (Ligature-resistant, Top Spud Only)\*\*
- ASFVCADA Ligature-resistant ADA Flush Valve Cover (Top Spud Only)\*\*
- AP Flush Valve Access Panel (Allows access to chase-mounted flush valve from fixture side)

**[Other Options CONTINUED:]**

- HS Hinged White Plastic Seat (No Cover, not recommended for Maximum Security/Ligature-resistant use)
- DC Decorator Color (Fixture exterior only - White)
- TF24H Hard-wired Transformer, 110VAC to 24VAC\*
- TF24P Plug-in Transformer, 110VAC to 24VAC\*
- HPS High Polish Seat
- TSC Toilet Shipping Cover
- RTH1 Wall Mounted Recessed Tissue Holder (Rear Mounted, Requires Accessible Chase)
- RTH2 Wall Mounted Recessed Tissue Holder (Front Mounted, 4-1/2" Depth)
- RFVB Remote Flush Valve with Box
- REFVB Remote Electronic Flush Valve with Box\*
- Other \_\_\_\_\_
- Other \_\_\_\_\_

**6.) Electronic Controls\* (Must Use Electronic Flush Valve):**

- WUFC-4000     Pneumatic     WMSII
- WUCC-3010 (Select WUCC-3010 Control if pairing a Toilet with a Lavatory or if the Toilet is selected with an (ET4) overflow option)

\*(Req. 110V power through ground fault interrupter (GFCI) receptacle / breaker)

**\*\*LIGATURE-RESISTANT DISCLAIMER**

This product is designed to minimize ligature points. While every effort has been made to reduce the possibility of ligature points, this product does not eliminate all risks. Ligature-Resistant products by Willoughby Industries are to be used in conjunction with, not as a replacement for, trained professionals.

**[CONTINUED IN NEXT COLUMN:]**

Approved For Manufacturing By: \_\_\_\_\_ Date: \_\_\_\_\_ Company: \_\_\_\_\_  
 Wall Thickness: \_\_\_\_\_ Wall Type: \_\_\_\_\_

**VERIFY ALL DIMENSIONS WITH FACTORY PRIOR TO ROUGH-IN**  
 WILLOUGHBY RESERVES THE RIGHT TO MAKE CHANGES IN DESIGN AND DIMENSIONS WITHOUT FORMAL NOTICE AND WITHOUT INCURRING OBLIGATION.

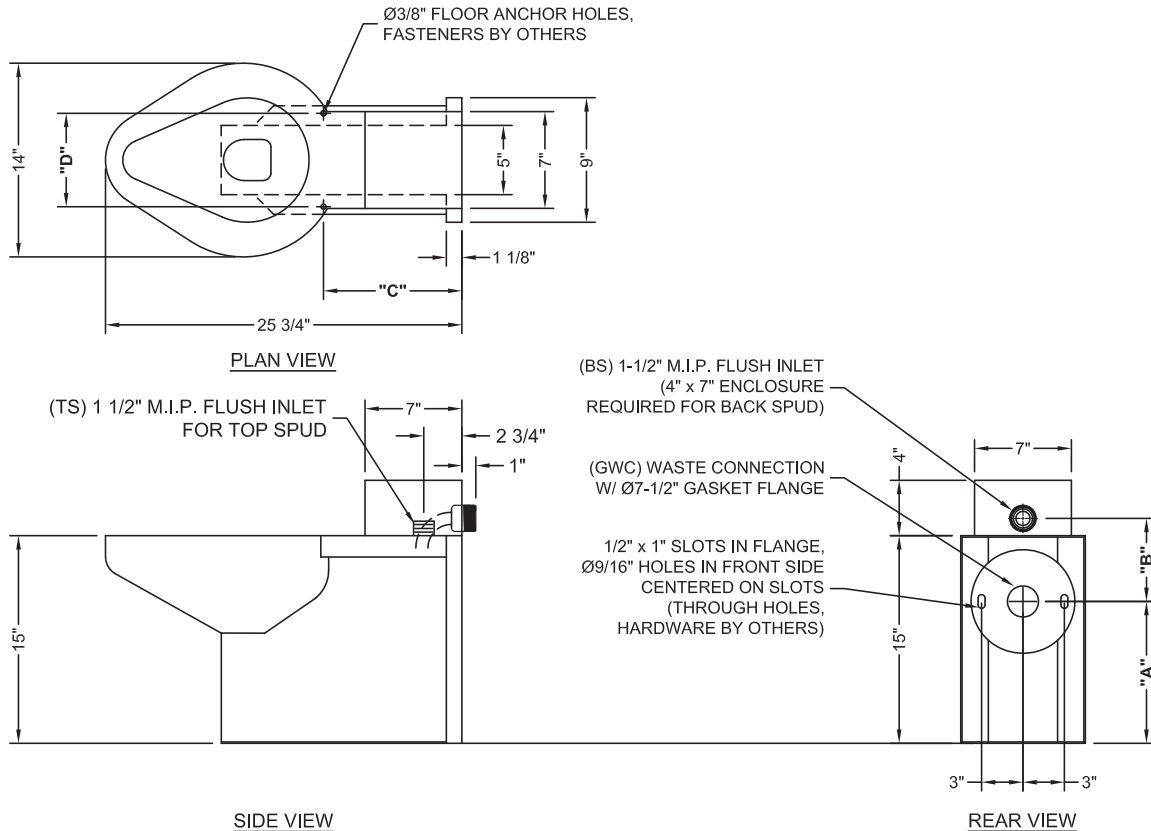

visit our website at [www.willoughby-ind.com](http://www.willoughby-ind.com)  
 5105 West 78th Street • Indianapolis, IN. 46268  
 (317) 875-0830 • Fax: (317) 875-0837 • (800) 428-4065



MADE IN THE U.S.A.