



BUILT TO LAST, IN AMERICA



WILLOUGHBY 1490 SERIES

Bariatric Toilet

Designed specifically for bariatric patients in healthcare environments.

Finally, an aesthetically pleasing toilet that is consistent with FGI's *Guidelines for Design of Construction of Health Care Facilities* and provides a **2,000 lb. weight rating** to properly serve bariatric patients.

Purpose Built

We consulted with leading healthcare professionals to create a toilet specifically for this market—we didn't retrofit an existing model.

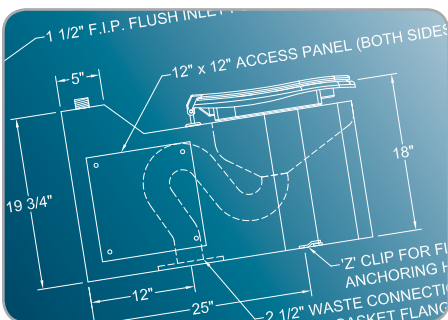

Built to Last

Crafted from heavy gauge, all-welded, type 304 stainless steel, this toilet is designed to last and to withstand loads that vitreous china can't.



Quality Finishing

Our toilet's stainless steel exterior is powder coated with anti-microbial gloss white enamel finish and the bowl interior has a sanitary bead-blasted stainless steel finish.



WILLOUGHBY

COUNT ON US.

800.428.4065 | www.willoughby-ind.com



2,000 lb. weight rating*

* The fixture (less hinged seat) will withstand loadings up to 2,000 pounds with no measurable deflection and loadings up to 5,000 pounds with no permanent damage. Bariatric toilet seat is rated for 1,200 pounds. Anti-microbial gloss white powder coating does not protect users against bacteria, viruses, or other disease organisms. Always use good hygienic cleaning practices.

Technical Specification: Model BET-1490-FM
Standard14.25" wide x 31.25" deep x 19.75" tall

REVIT details available at
www.willoughby-ind.com

Willoughby Industries, Inc.
5105 West 78th Street, Indianapolis, IN 46268
800.428.4065 | fax 317.875.0837
www.willoughby-ind.com

