

Installation & Operation Manual

E1L1 and E1L2 Lead-Free Electronic Series Valves (Plastic Bodied)

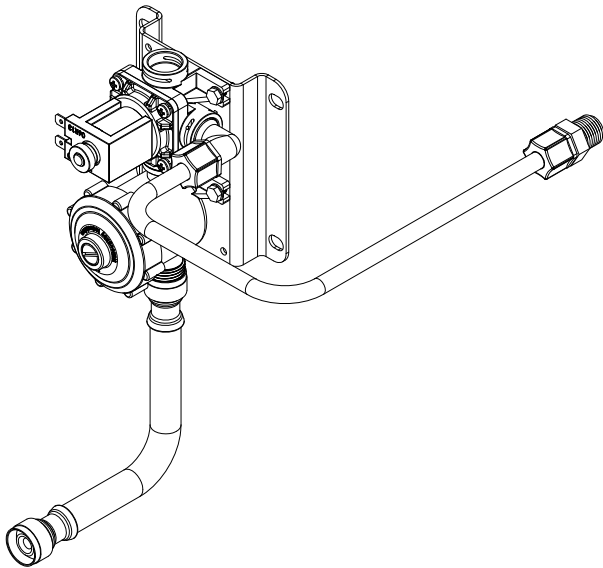

E1L1

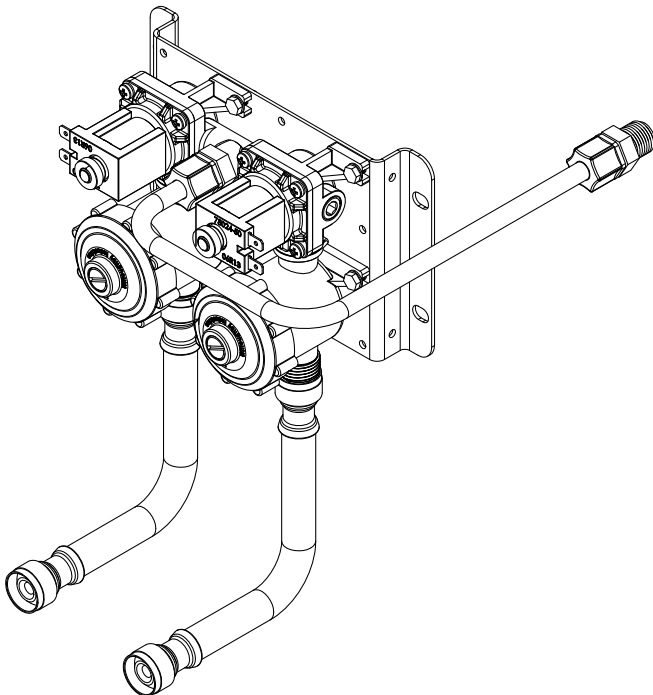

E1L2

Table of Contents

Pre-Installation Information.....	3
General Specifications.....	4
Physical Dimensions	
E1L1 Single Temp Solenoid Valve Assembly #980408.....	5
E1L11 Valve Breakdown.....	6
E1L12 Manifold Valve Breakdown.....	7
E1L21 Valve Breakdown.....	8
E1L22 Manifold Valve Breakdown.....	9
Checking Contents	11
Installation Instructions	12
Electronic Piezo Switch Detail	13
Jaco Fitting Instructions.....	14
Care and Maintenance	
Electronic Valve Assembly Operation and Maintenance	15
Cleaning Instructions	16
Troubleshooting Electronic Valves	17
Replacement Part Numbers.....	
E1L1 Single Temp Solenoid Valve Assembly #980408.....	18
Checkstop Breakdown P/N 980183.....	19
Drawings	
Pushbutton Assembly #600313	20
Pushbutton Assembly #600314LR	21
Warranty.....	22



Willoughby Industries, Inc.

5105 West 78th Street
Indianapolis, IN 46268

Toll Free: (800) 428-4065

Local: (317) 875-0830

Fax: (317) 875-0837

www.willoughby-ind.com

WILLOUGHBY

Rev. 1/2026

MADE IN THE U.S.A.



(Page left intentionally blank)

Pre-Installation Information

Installation notice!

Check Rough-In location **PRIOR** to installation

Flush lines thoroughly **PRIOR** to hook-up

When installing the **Willoughby Industries' E1L1 and E1L2 Lead-free Electronic Series Valves:**

Before step 1 of the installation instructions, ensure that rough-ins are in the correct location.

The valve assembly, including the spray head, **MUST NOT BE** connected until *after* all lines have been flushed to remove the small particles of debris that are inherent with new construction projects and all chemicals that are used in flushing are purged from the system.

Chemicals used in flushing plumbing systems can attack the internal components of the valve and spray head and severely damage them, so any flushing of the system must be followed by a full flushing with pure water to clear any harsh chemicals remaining in the system. Debris in the system if allowed to enter the valve assembly and spray head can cause poor performance or outright failure.

Again **DO NOT** attempt to connect the valve assembly and spray head until *after* all flushing is complete and pure water is the only media that will be passing through the system. Damage to the valve assembly or spray head caused by harsh chemicals or debris will not be covered by the manufacturer's warranty.

DO NOT use pipe joint compound on any threaded connections to plastic componets, use teflon thread tape only.

Installation notice!

Check Rough-In location **PRIOR** to installation

Flush lines thoroughly **PRIOR** to hook-up

General Specifications

Electronic valve assembly shall be Willoughby Model No. E1L1 or E1L2 as noted. Valve shall be constructed of plastic and stainless steel materials and complies with NSF-61 standard.

Stainless steel pushbutton switches on the fixture shall be wired to an appropriate electronic valve control (select from the list of control choices). The vandalproof pushbuttons shall be keyed and non-removable from the front of the fixture. The pushbuttons shall require less than 5 lbs. of force to operate.

The single temperature solenoid valve assembly shall include a stainless steel screwdriver stop and an integral mounting bracket. Replaceable stainless steel strainer and optional 0.5 GPM flow control shall be field serviceable. The connection to the filler/bubbler/showerhead shall be 3/8" O.D. flexible tubing. The water inlet shall be 1/2" FPT (S/S flexible supply line) and shall be reversible for either top or bottom supply. Valve assembly shall be accessible from the pipe chase only.

Flexible tubing shall be supplied for walls up to 8 inches thick. Recommended operating pressure shall be 35-70 psi. The valve shall withstand pressures up to 90 psi. Cost reducing manifolded valves shall consist of multiple valve assemblies served by a common supply line. A 24 volt AC source shall be required for timer and valve operation.

Physical Dimensions

E1L1 Single Temp Solenoid Valve Assembly #980408

ITEM #	SUB-ASSY#	PART #	DESCRIPTION	QTY.
1	N/A	980534	NYLON NUT, 5/16-18	1
2	N/A	980532	COIL, 24V DC	1
3	N/A	980170	#8-32 x 1/2 " SCREW	4
4	N/A	980002	SPLIT LOCK WASHER	4
5	N/A	980530	ARMATURE CAP, 24v VALVE	1
6	N/A	980533	SPRING, 5/8 24v VALVE	1
7	N/A	980565	ARMATURE BUMPER ASSEMBLY, EL VALVE	1
8	980305	980128	3 PRONGED INSERT	1
9		980129	WATER SIDE DIAPHRAGM	1
10	N/A	980420	SINGLE TEMP BASE W/INSERTS	1

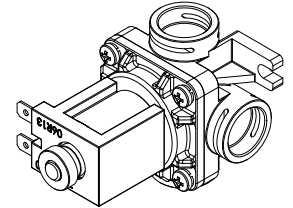

ASSEMBLED VIEW

NOTE: REPAIR KIT ORDERING #S ARE LISTED IN THE EXPLODED VIEW.

NOTE: PARTS LISTED IN THE PVK REPAIR KITS ARE NOT SOLD INDIVIDUALLY

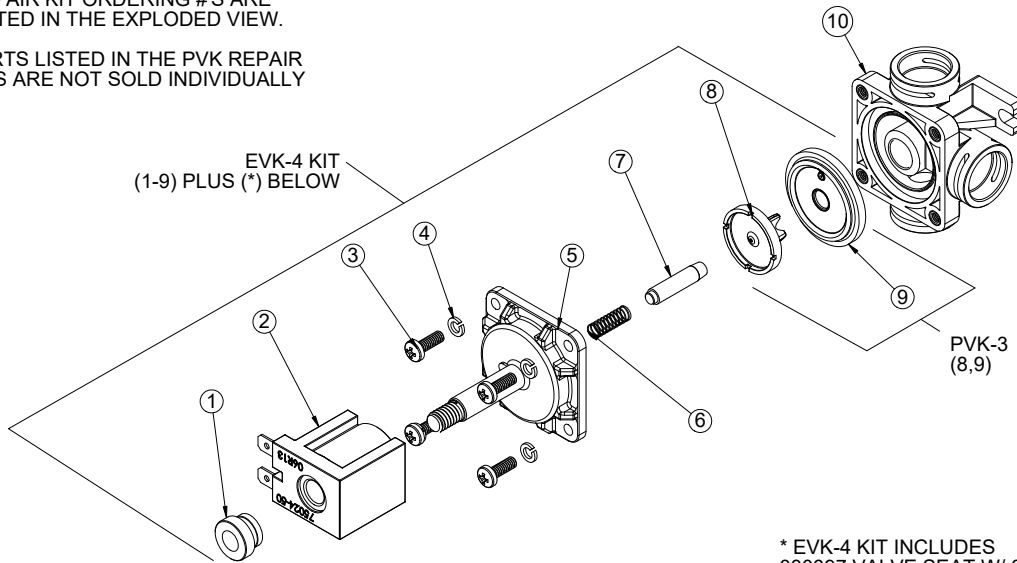

Physical Dimensions

E1L11 Valve Breakdown

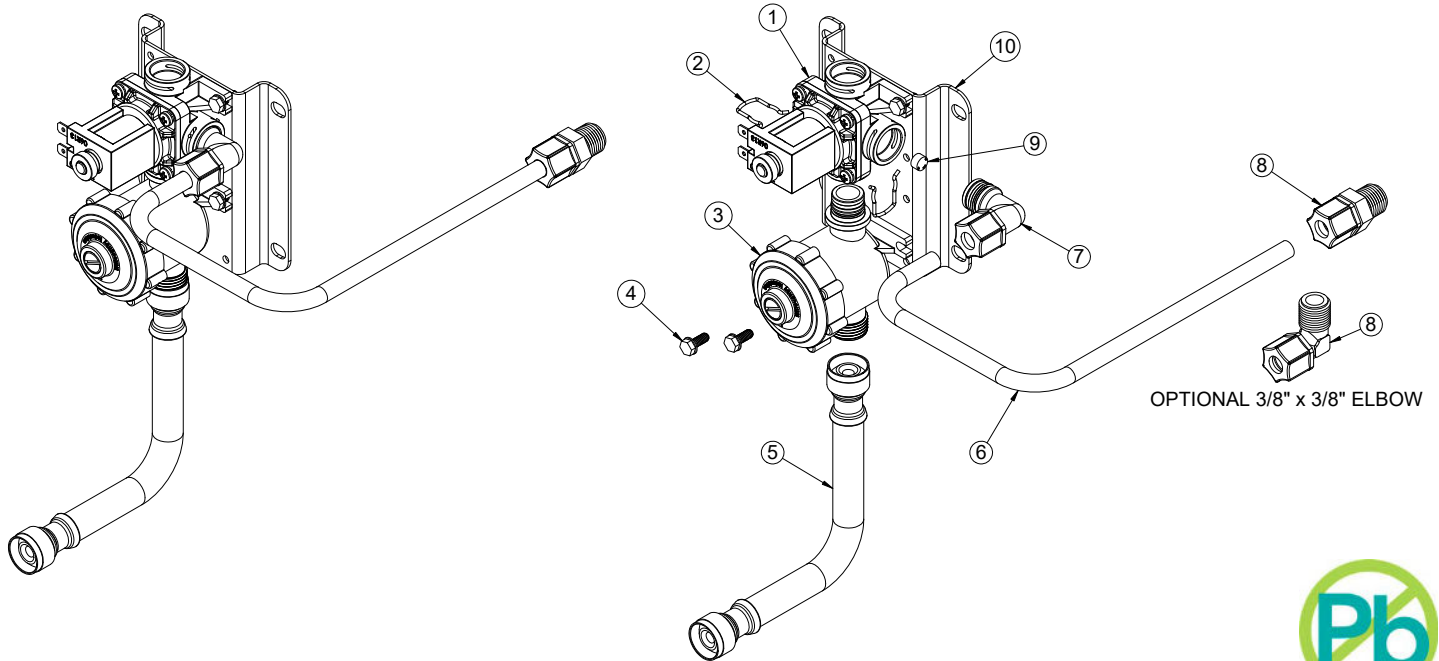

ITEM NO.	PART #	DESCRIPTION	QTY
1	980408PR	E1L VALVE ASSEMBLY, RIGHT-PLUGGED PORT	1
2	980140	SPRING CLIP	2
3	980183	CHECKSTOP ASSEMBLY	1
4	800133	#10-16 SELF TAP TYPE B HEX HEAD SCREW	4
5	980506	(OPTIONAL) 6" STAINLESS STEEL FLEX HOSE	1
5	980520	(OPTIONAL) 20" STAINLESS STEEL FLEX HOSE	1
6	600523	FLEXIBLE TUBING 3/8" (10mm) O.D. 20 FT. TOTAL	PERFOOT
7	980600A	VALVE FITTING ASSEMBLY, 3/8" ELBOW	1
8	320566	(OPTIONAL) CONNECTOR, 3/8" TUBE x 3/8" MPT	1
8	320577	(OPTIONAL) ELBOW, 3/8" TUBE x 3/8" MPT	1
9	380138	FLOW CONTROL 0.5 GPM (RED)	1
10	980501	PM1 VALVE BRACKET	1

Physical Dimensions

E1L12 Manifold Valve Breakdown

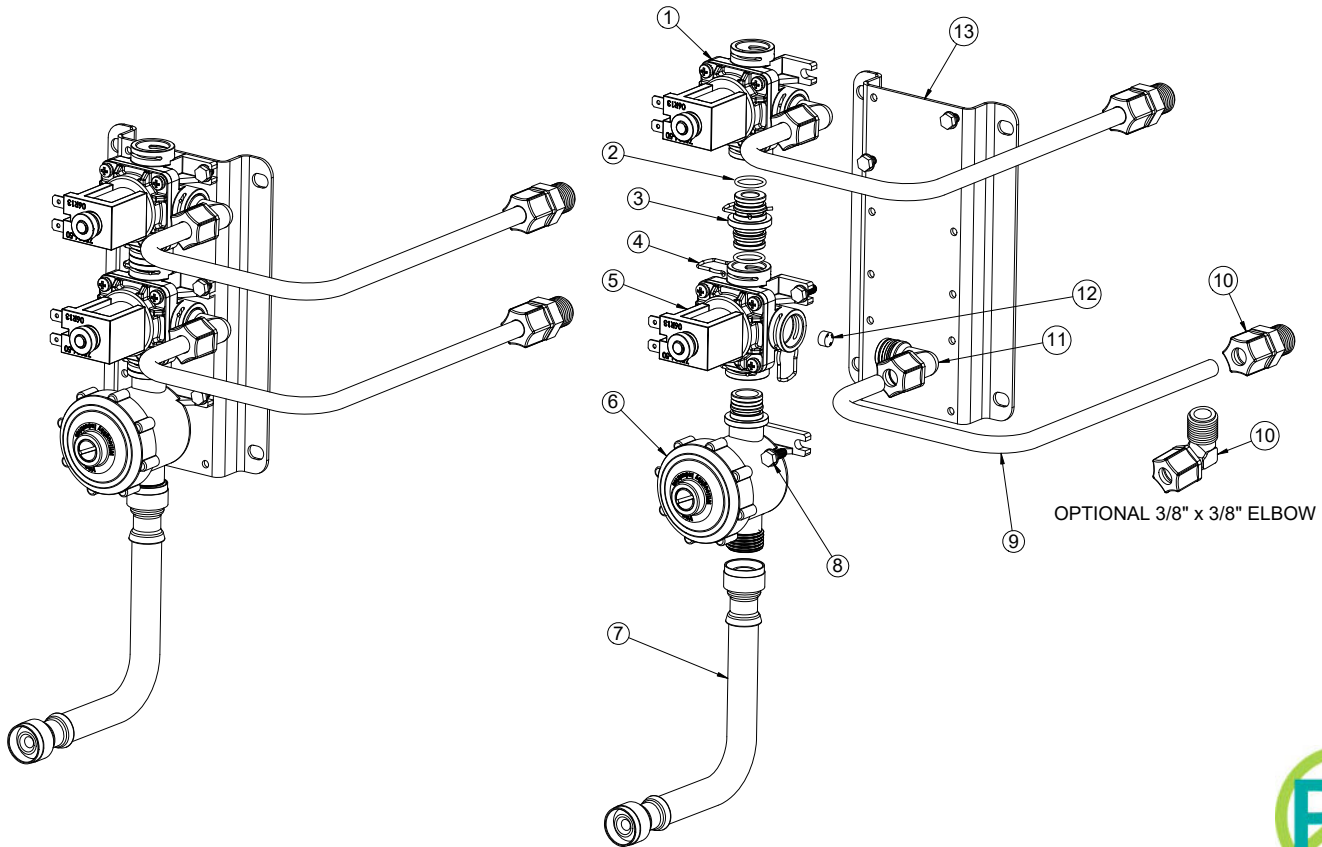

ITEM NO.	PART #	DESCRIPTION	QTY
1	980408PR	E1L VALVE ASSEMBLY, RIGHT-PLUGGED PORT	1
2	980164	'O'-RING, #015	2
3	980197	PLASTIC VALVE COUPLING	1
4	980140	SPRING CLIP	5
5	980408	E1L VALVE ASSEMBLY	1
6	980183	CHECKSTOP ASSEMBLY	1
7	980506	(OPTIONAL) 6" STAINLESS STEEL FLEX HOSE	1
7	980520	(OPTIONAL) 20" STAINLESS STEEL FLEX HOSE	1
8	800133	#10-16 SELF TAP TYPE B HEX HEAD SCREW	6
9	600523	FLEXIBLE TUBING 3/8" (10mm) O.D. 20 FT. TOTAL	PER FOOT
10	320566	(OPTIONAL) CONNECTOR, 3/8" TUBE x 3/8" MPT	2
10	320577	(OPTIONAL) ELBOW, 3/8" TUBE x 3/8" MPT	2
11	980600A	VALVE FITTING ASSEMBLY, 3/8" ELBOW	2
12	380138	FLOW CONTROL 0.5 GPM (RED)	2
13	9805012	PM1-MA2 VALVE BRACKET-PLASTIC	1

Physical Dimensions

E1L21 Valve Breakdown

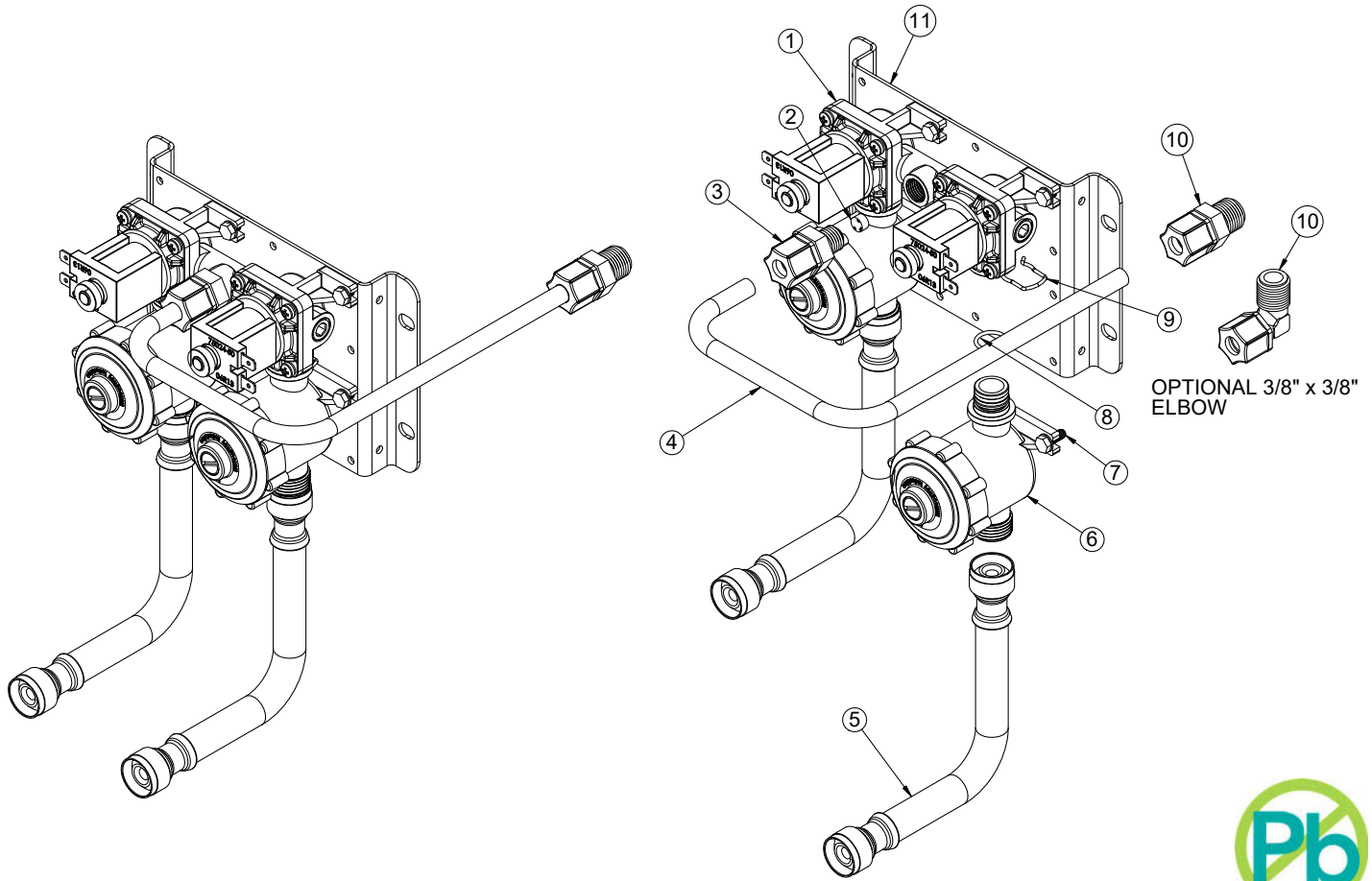

ITEM NO.	PART #	DESCRIPTION	QTY
1	980409	DUAL TEMP, WILLOUGHBY SOLENOID PARTS ASSY (E1L2)	1
2	380138	FLOW CONTROL 0.5 GPM (RED)	1
3	321010	CONNECTOR, 3/8" TUBE x 1/4" MPT	1
4	600523	FLEXIBLE TUBING 3/8" (10mm) O.D. 20 FT. TOTAL	PER FOOT
5	980506	(OPTIONAL) 6" STAINLESS STEEL FLEX HOSE	2
5	980520	(OPTIONAL) 20" STAINLESS STEEL FLEX HOSE	2
6	980183	CHECKSTOP ASSEMBLY	2
7	800133	#10-16 SELF TAP TYPE B HEX HEAD SCREW	8
8	980164	'O'-RING #015	2
9	980140	SPRING CLIP	2
10	320566	(OPTIONAL) CONNECTOR, 3/8" TUBE x 3/8" MPT	1
10	320577	(OPTIONAL) ELBOW, 3/8" TUBE x 3/8" MPT	1
11	980502	PM2 VALVE BRACKET-PLASTIC	1



Physical Dimensions

E1L22 Manifold Valve Breakdown

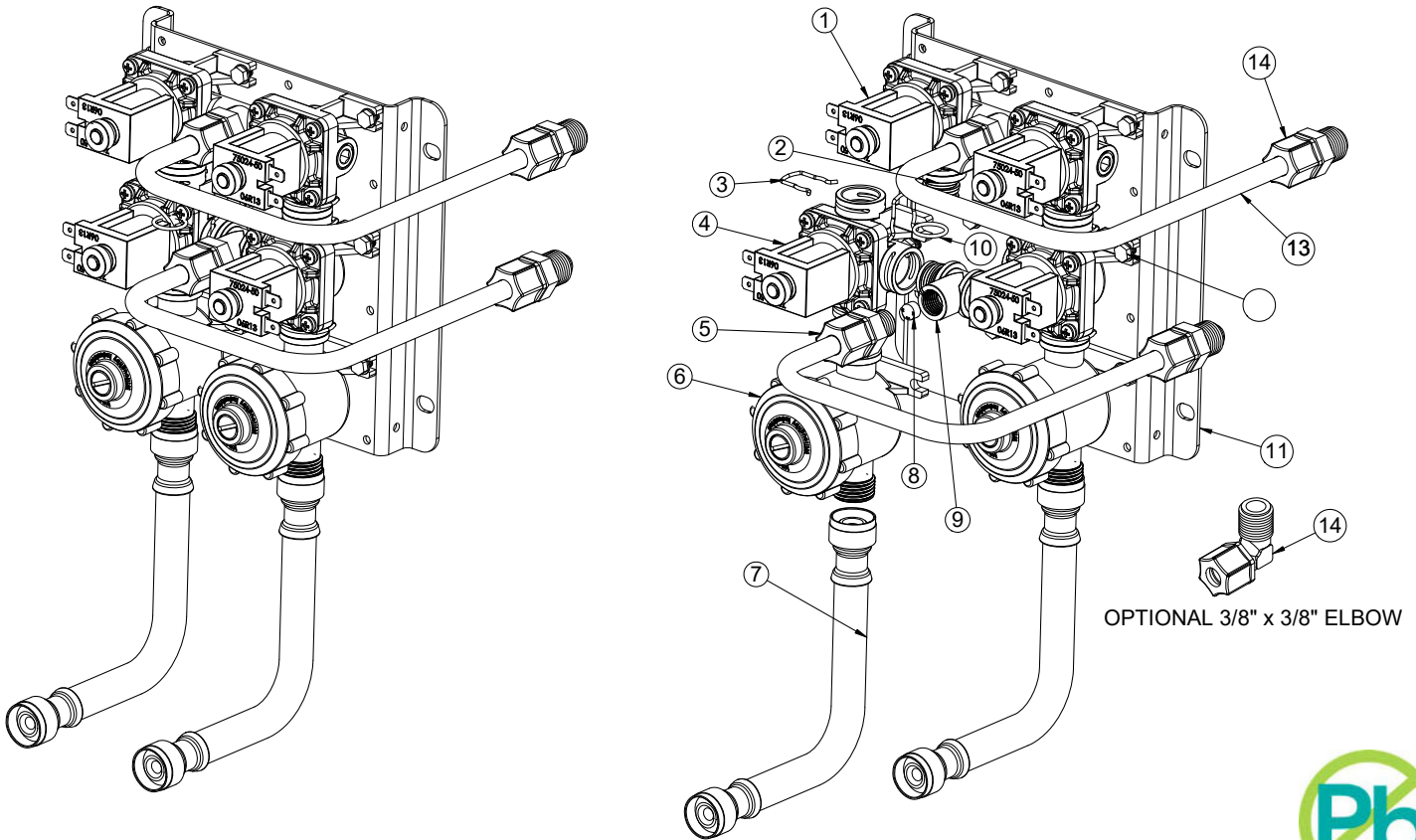

ITEM NO.	PART #	DESCRIPTION	QTY
1	980409	DUAL TEMP, WILLOUGHBY SOLENOID PARTS ASSY (E1L2)	1
2	980197	PLASTIC VALVE COUPLING	2
3	980140	SPRING CLIP	8
4	980408	E1L VALVE ASSEMBLY	2
5	321010	CONNECTOR, 3/8" TUBE x 1/4" MPT	2
6	980183	CHECKSTOP ASSEMBLY	2
7	980506	(OPTIONAL) 6" STAINLESS STEEL FLEX HOSE	2
7	980520	(OPTIONAL) 20" STAINLESS STEEL FLEX HOSE	2
8	380138	FLOW CONTROL 0.5 GPM (RED)	2
9	980196	PLASTIC VALVE 'T'	1
10	980164	'O'-RING, #015	3
11	9805022	PM22 VALVE MOUNTING PLATE	1
12	800133	#10-16 SELF TAP TYPE B HEX HEAD SCREW	12
13	600523	FLEXIBLE TUBING 3/8" (10mm) O.D. 20 FT. TOTAL	PER FOOT
14	320566	(OPTIONAL) CONNECTOR, 3/8" TUBE x 3/8" MPT	2
14	320577	(OPTIONAL) ELBOW, 3/8" TUBE x 3/8" MPT	2



(Page left intentionally blank)

Check Contents

- Separate all parts from packaging and make sure all parts are accounted for before discarding any packaging material. If any parts are missing, do not attempt to install E1L1 or E1L2 Lead-free Electronic Series Valves until you obtain the missing parts.

NOTE: Before beginning installation, all supply, drain and waste piping for the E1L1 and E1L2 Lead-free Electronic Series Valves must be completed according to specified rough-ins. If you have not received rough-in details, please contact Willoughby Industries, Inc. (800) 428-4065

IMPORTANT: Flush all the water supply lines before making connections.

Installation Instructions

- (1) Clear and flush all supply lines to valves.
- (2) Mount the valves at any convenient location. Make sure to have sufficient length of wire leads to reach between the electrical piezo switches and the valves.
- (3) Connect water supply lines to valves. Close the check stop valves.
- (4) Assemble the push buttons to the fixture backsplash. Connect the push button wire leads to the timer assembly or Water Management System.
- (5) Connect the valve wires from the timer or Water Management System to the solenoid valves.
- (6) Install 3/8" MPT x comp. plastic adapter into filler/bubbler or shower head, on fixture.
- (7) Insert one end of plastic tube into adapter on filler/bubbler or shower head, and the other end into adapter on valve assembly.
- (8) Open water supply stops and checkstop valves, checking for leaks.
- (9) Connect the power supply transformer into a 110 volt power source.
- (10) Actuate push buttons several times to clear water lines and valves of trapped air. Check for leaks at all connections.
- (11) Adjust hot and cold water mixing valve, if applicable, by pressing pushbutton and releasing to start the water flowing.

Installation Instructions (cont.)

Electronic Piezo Switch Detail

✓	WIRE TERMINATOR	INV. #
	BARE STRIPPED WIRE	701179
	1/4" FEMALE SPADE CONNECTION	701179-C

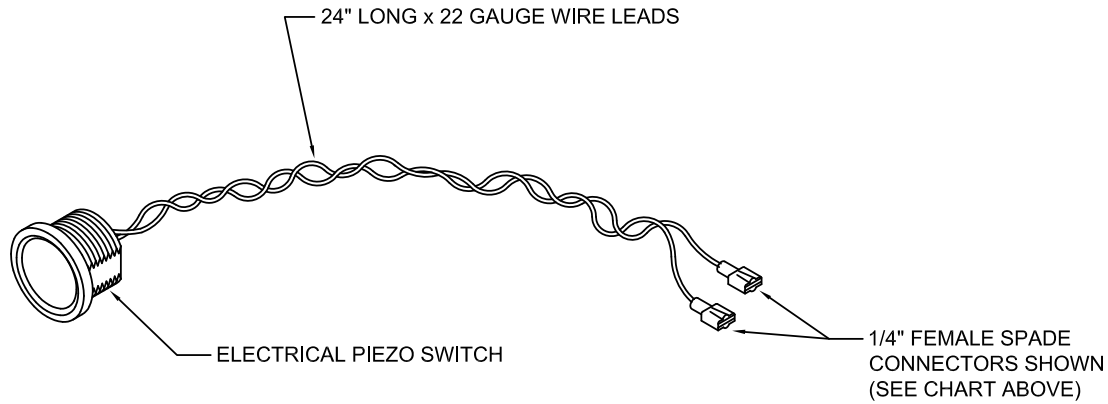

PIEZO SWITCH SPECIFICATIONS

PIEZO SWITCH HOUSING:

- MATERIAL: STAINLESS STEEL
- MOUNTING GEOMETRY: DOUBLE 'D' HOUSING
- SUPPLIED WITH NUT FOR MOUNTING
- 2 FT. LEADS INTEGRAL TO SWITCH (EXTENSION CABLES CAN BE SPECIAL ORDERED)
- EXTERNAL HOUSING OF SWITCH ELECTRICALLY ISOLATED FROM CIRCUITRY OF SWITCH

OPERATIONAL RATINGS:

- ACTUATION FORCE: LESS THAN 5 LBS.
- MAXIMUM VOLTAGE: 36 VOLTS AC/DC
- MAXIMUM AMPERAGE: 100 MA

Installation Instructions (cont.)

Jaco Fitting Instructions



Note: It is not necessary to disassemble this fitting for application. Merely insert tubing to stop and tighten seal.

1. Cut tubing end squarely and remove the internal burrs.
2. Insert the tubing through the back of the nut all the way through the nut assembly to the tube stop in the fitting body (see illustration). If the tubing does not enter the nut easily, loosen the nut one turn and reinsert the tubing all the way to the tube stop in the fitting body.
3. Turn the nut hand tight.
4. Wrench tighten the nut 1½ - 2 turns.
5. All nuts must be retightened when the system reaches projected operating temperature.

Note: To ensure proper assembly, tubing MUST be fully inserted into the fitting body all the way to the tube stop.

Note: Squeaking sound when tightening nut is normal. For pipe threaded connections, Teflon tape must be used.

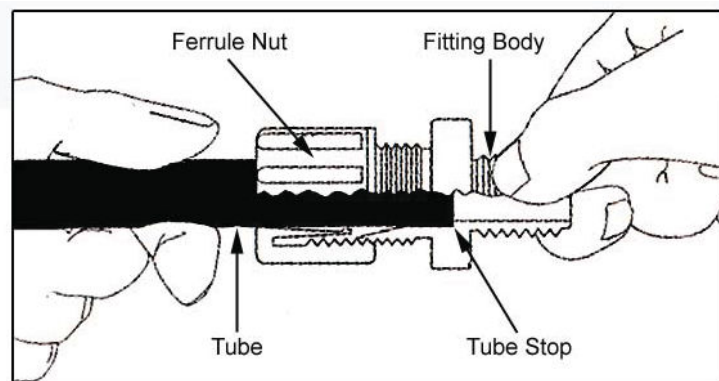
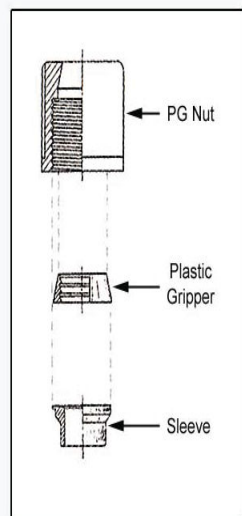

Care and Maintenance

Electronic Valve Assembly Operation and Maintenance

The Willoughby Electronic Valve Assembly is designed as an electrically operated, normally closed valve, low voltage valve. This type of valve is used for lavatories as well as showers.

A strainer/checkstop is an integral part of the valve assembly and provides a means of shutting off the water if the valve needs servicing. A check valve in the checkstop eliminates cross flow of hot or cold water into the opposite supply line. Fine mesh stainless steel strainers keep normal line debris from interfering with the mechanical components of the valves.

By virtue of its design, the electronic valve is a 24 VAC operated valve and is a normally closed valve. The operating sequence of the valve begins with pressing the push button. Based upon what the valve is connected to, a timer or a water management system, the valve will open and stay open until the voltage stops.

The valve contains a valve seat, water side diaphragm, an armature and a coil. When voltage is applied to the coil, the armature is pulled upwards. The water pressure will then push up against the rubber diaphragm and water will flow thru to the outlet side of the valve.

The bypass hole is the rubber diaphragm assist the valve in closing. The bypass orifices are molded in the edge of the diaphragm. Both of these orifices must be clear for the valve to function properly.

Care and Maintenance

Cleaning Instructions

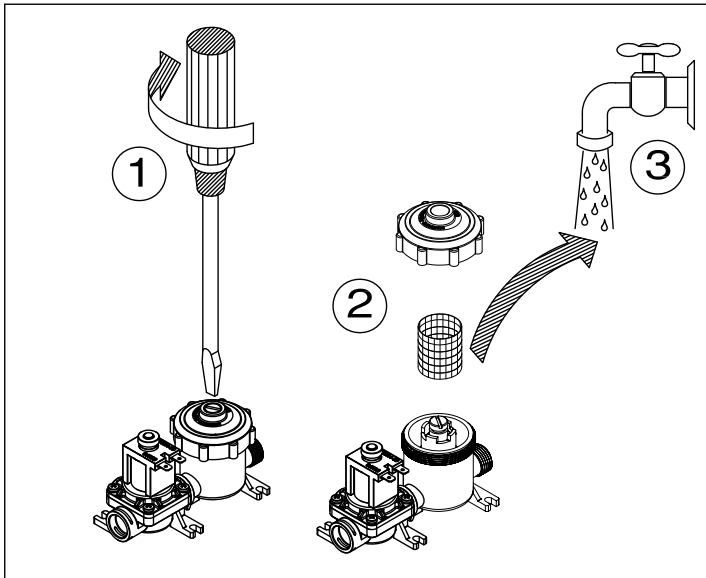

To clean strainer:

1. Close stop
2. Remove strainer cap & strainer
3. Rinse strainer

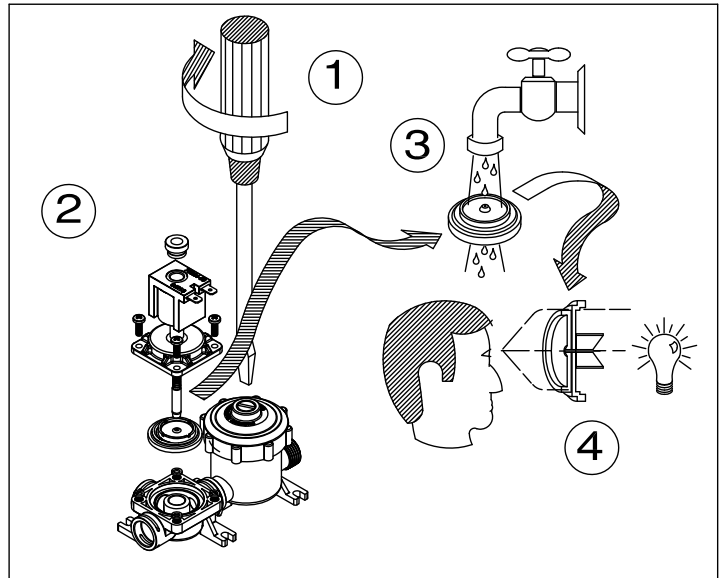

To clean valve:

1. Close stop
2. Carefully remove valve motor
3. Wash water side diaphragm
4. Check for unobstructed diaphragm openings (3)



Willoughby Industries, Inc.

Troubleshooting Electronic Valves

VALVE LEAKS, WILL NOT OPEN, OR WILL NOT SHUT OFF:

- (1) Make sure the checkstop/strainer on the supply line to the valve is fully open. Do not partially close the checkstop for any reason as it is not a throttling valve. The check stop should be fully open (normal operation) or fully closed (when servicing the valve).
- (2) Close the check stop, then remove the cap. Remove and inspect the strainer in the supply line to make sure the strainer is not blocked or partially blocked and prohibiting water flow.
- (3) Check the voltage at the valve for 24 VAC after pressing the pushbutton.
- (4) Verify that the appropriate DIP switches are in the "ON" position on the timer (if applicable).
- (5) If the above steps do not solve the problem, follow the steps below to disassemble and inspect the valve:
 - a) Separate valve motor from valve base by removing the four (4) #8 screws.
 - b) Inspect the water diaphragm assembly to see if bypass hole in diaphragm is blocked. Remove any debris by blowing on diaphragm or using compressed air. DO NOT use any tool (such as a straight pin) to remove any debris. Enlarging the hole will shorten the valve cycling, cause erratic behavior, and possibly shorten the life of the valve.
 - c) Inspect seating area on valve base to make sure no debris, pitting, or scoring is present. Clean seat as necessary.
 - d) Inspect seating area on diaphragm for debris and clean as necessary. If debris has caused permanent indentations in the rubber, it may have to be replaced.
 - e) Check the rubber bumper on the end of the solenoid armature for any debris, marks, indentations, scratches, or deformations. Replacement may be necessary.
 - f) Ensure that the armature spring is in place and not missing.
 - g) Using the exploded view provided with this manual, reassemble the valve and test it's operation to determine if the problem has been fixed.

Replacement Part Numbers

E1L1 Single Temp Solenoid Valve Assembly #980408

ITEM #	SUB-ASSY#	PART #	DESCRIPTION	QTY.
1	N/A	980534	NYLON NUT, 5/16-18	1
2	N/A	980532	COIL, 24V DC	1
3	N/A	980170	#8-32 x 1/2 " SCREW	4
4	N/A	980002	SPLIT LOCK WASHER	4
5	N/A	980530	ARMATURE CAP, 24v VALVE	1
6	N/A	980533	SPRING, 5/8 24v VALVE	1
7	N/A	980565	ARMATURE BUMPER ASSEMBLY, EL VALVE	1
8	980305	980128	3 PRONGED INSERT	1
9		980129	WATER SIDE DIAPHRAGM	1
10	N/A	980420	SINGLE TEMP BASE W/INSERTS	1

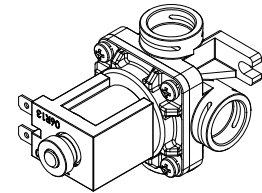

ASSEMBLED VIEW

NOTE: REPAIR KIT ORDERING #S ARE LISTED IN THE EXPLODED VIEW.

NOTE: PARTS LISTED IN THE PVK REPAIR KITS ARE NOT SOLD INDIVIDUALLY

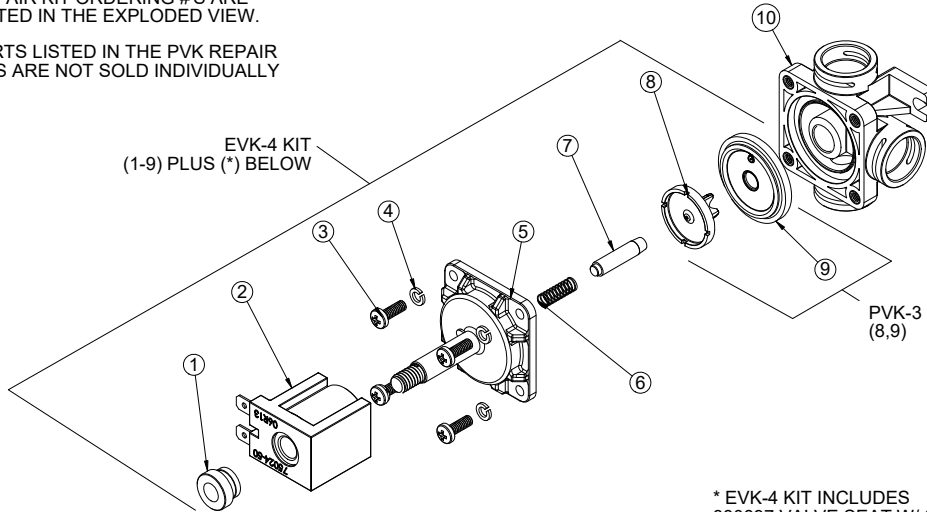

* EVK-4 KIT INCLUDES
 380897 VALVE SEAT W/ O-RING (NOT SHOWN)



Replacement Part Numbers

Checkstop Breakdown P/N 980183

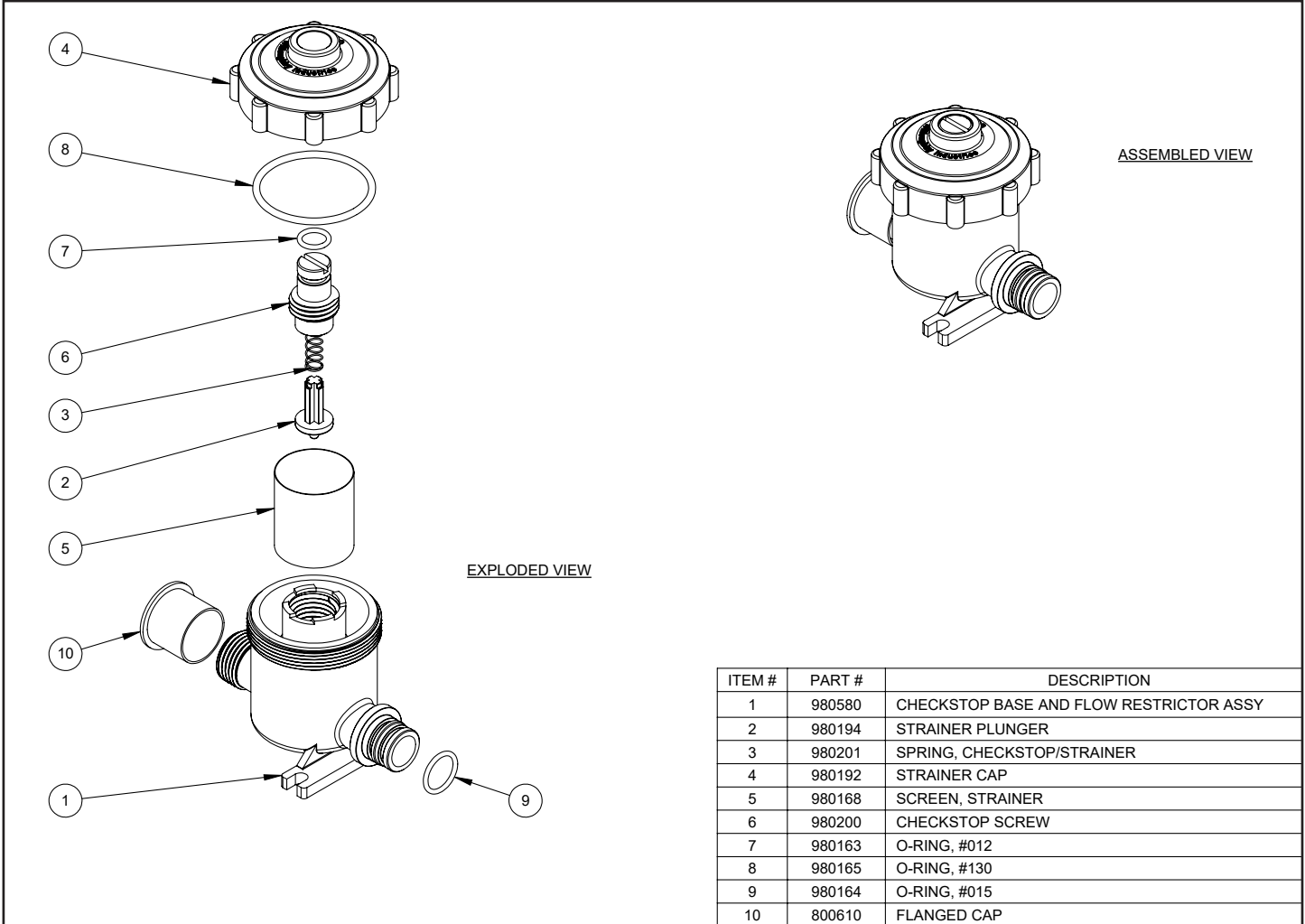

Drawing- Pushbutton Assembly #600313

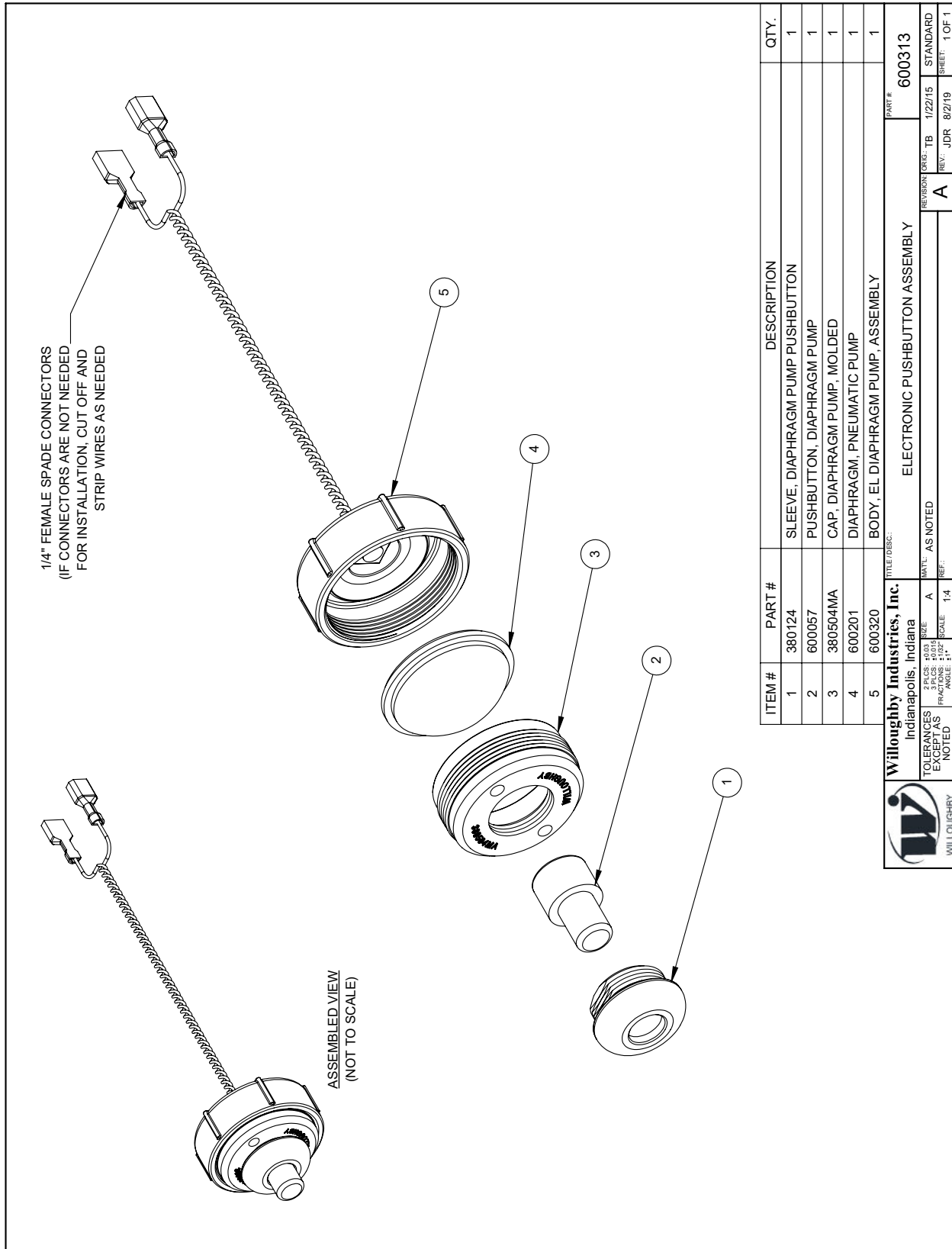

Drawing- Pushbutton Assembly #600314LR

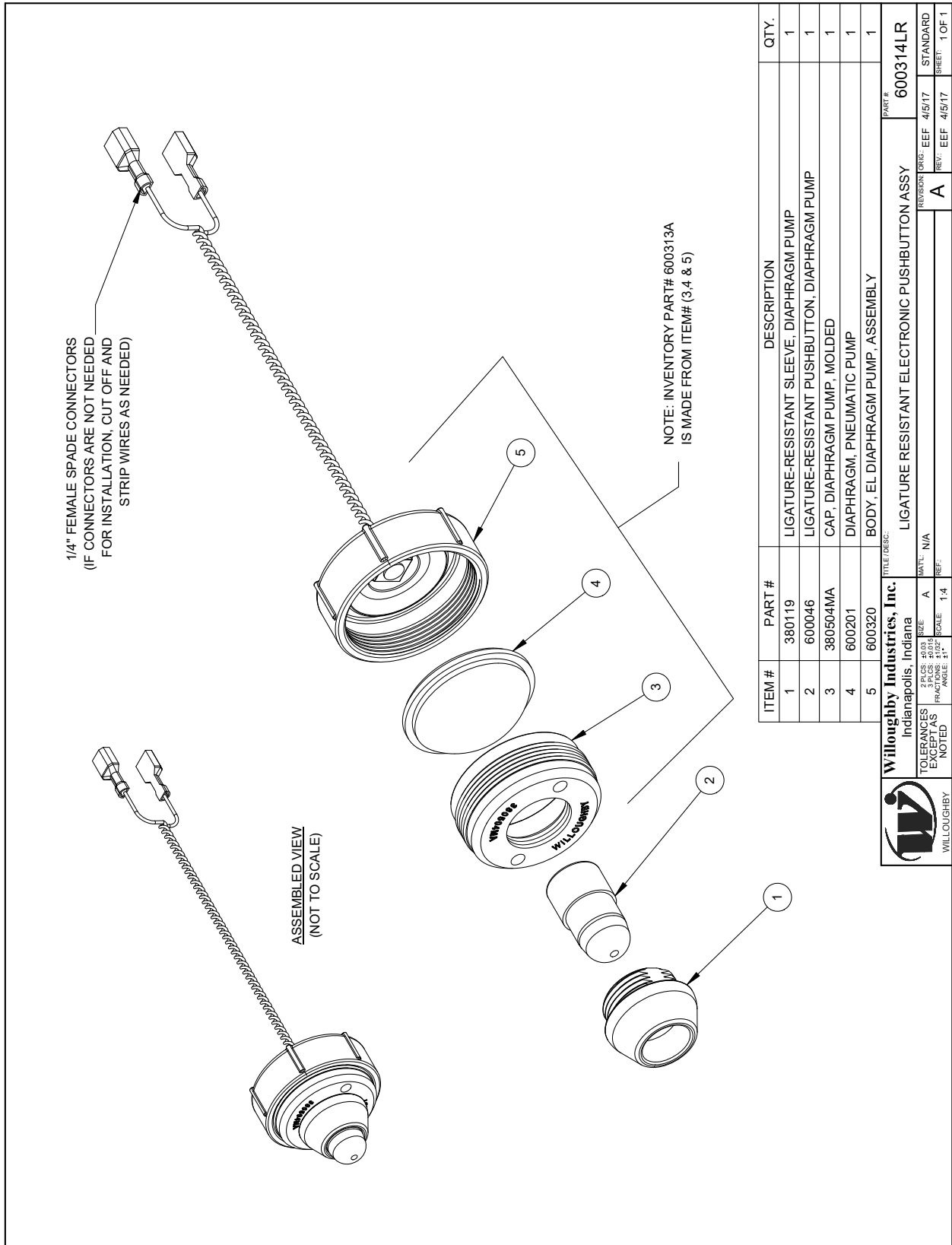

ITEM #	PART #	DESCRIPTION	QTY.
1	380119	LIGATURE-RESISTANT SLEEVE, DIAPHRAGM PUMP	1
2	600046	LIGATURE-RESISTANT PUSHBUTTON, DIAPHRAGM PUMP	1
3	380504MA	CAP, DIAPHRAGM PUMP, MOLDED	1
4	600201	DIAPHRAGM, PNEUMATIC PUMP	1
5	600320	BODY, EL DIAPHRAGM PUMP, ASSEMBLY	1

Willoughby Industries, Inc.
Indianapolis, Indiana

TOLERANCES EXCEPT AS NOTED

2 PLCS #003
FRACTIONS #182

SIZE A
SCALE 1/4

MATL. N/A
REF.

REVISION (DRG) EEF 4/5/17
REV. EEF 4/5/17

PART # 600314LR
TITLE/DESC. LIGATURE RESISTANT ELECTRONIC PUSHBUTTON ASSY

STANDARD SHEET 1 OF 1

Warranty

Willoughby Industries, Inc. warrants to commercial and institutional purchasers only that each unit will be free from defects in workmanship and materials under normal use and service upon the following terms and conditions. The period during which components are warranted is as follows:

1. Solid surface components are warranted for 2 years from date of shipment.
2. All other components warranted for 1 year from date of shipment.

This warranty does not cover installation or any other labor charges and does not apply to any components damaged by accident, abuse, improper installation or improper maintenance. This warranty does not cover any installation that did not comply with national, state and local building, plumbing or electrical codes. The warranty is limited to replacing or repairing at manufacturer's option, transportation charges prepaid by the purchaser, any component or part which upon our inspection shall be deemed as defective within the limitations of this warranty. The replacement or repair of defective units as stated in this warranty shall constitute the sole remedy of the purchaser and the sole liability of Willoughby Industries, Inc. Willoughby Industries, Inc. shall not otherwise be liable under any indirect damages caused by defects in the repair or replacement thereof.

This warranty only extends to commercial and industrial purchasers and does not extend to any others, including consumer customers of commercial institutional purchasers. This warranty is in lieu of all other warranties, expressed or implied, including implied warranty of merchantability or fitness for a particular purpose or otherwise.