

# Installation & Operation Manual

## CWSSS Series

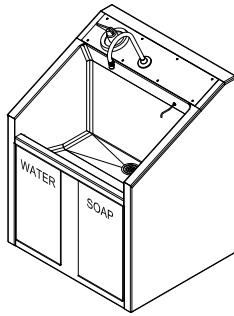

**CWSSS-1**

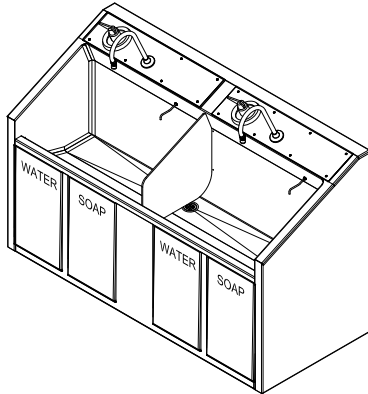

**CWSSS-2**

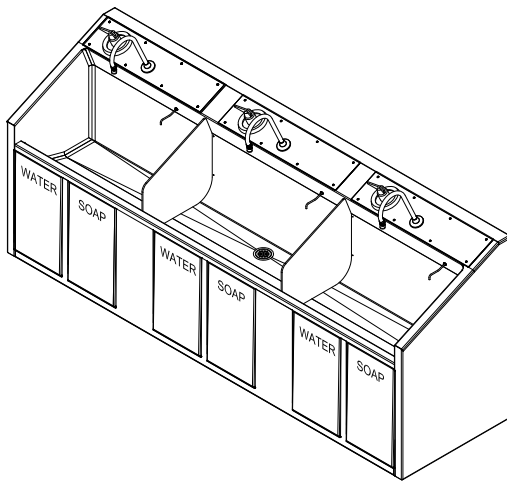

**CWSSS-3**

(SOME OPTIONS MAY BE SHOWN)

## One-, Two-, and Three-station Stainless Steel Scrub Sink (IR) and (KA) Models

### Table of Contents

Pre-Installation Information.....	3
Physical / Rough-in Dimensions.....	4
Parts List.....	10
Exploded-view Drawing.....	11
Hardware Identification.....	12
Required Installation Supplies.....	13
Installation Instructions.....	
Step 1: Unpacking the Fixture.....	14
Step 2: Installing the Wall Carrier Assembly (MC)	
.....	15
Step 3: Installing the Fixture 'Z' Clips and	
Anchors.....	16
Step 4: Fixture Preparation.....	17
Step 5: Drain Assembly.....	18
Step 6A: Connections for (IR) Infrared Actuators	
.....	19
Step 6B: Connections for (KA) Knee-activated	
Actuators.....	20
Step 7: Mounting the Fixture Assembly.....	21
Step 8: Final Assembly.....	22
(T/P) Temp./Pressure Mixing Valve Installation....	23
(TMV) Thermostatic Mixing Valve Installation.....	24
(IR) Infrared Sensor Installation Instructions.....	25
Care and Maintenance.....	26
Troubleshooting.....	
Infrared Sensors.....	27
Electronic Valves.....	28
Drawings.....	
Wall Carrier Details.....	29
Electronic Valve Details.....	32
Warranty.....	35
Manufacturers Appendix.....	37
HIGHLAND LABS Model 415.....	38-39
HIGHLAND LABS Model 470.....	40-41
VEEDER-ROOT Series C342.....	42-45



**Willoughby Industries, Inc.**

5105 West 78th Street  
Indianapolis, IN 46268

Toll Free: (800) 428-4065

Local: (317) 875-0830

Fax: (317) 875-0837

www.willoughby-ind.com

**WILLOUGHBY**

Rev. 11/2024

MADE IN THE U.S.A.



**(Page intentionally left blank)**

## Pre-Installation Information

# Installation notice!

Check Rough-In location **PRIOR** to installation

Flush lines thoroughly **PRIOR** to hook-up

When installing the **Willoughby Industries' CWSSS Series** scrub sink system:

Before Step 1 of the installation instructions, ensure that rough-ins are in the correct location.

The valve assembly, including the spray head, **MUST NOT BE** connected until *after* all lines have been flushed to remove the small particles of debris that are inherent with new construction projects and all chemicals that are used in flushing are purged from the system.

Chemicals used in flushing plumbing systems can attack the internal components of the valve and spray head and severely damage them, so any flushing of the system must be followed by a full flushing with pure water to clear any harsh chemicals remaining in the system. Debris in the system if allowed to enter the valve assembly and spray head can cause poor performance or outright failure.

Again **DO NOT** attempt to connect the valve assembly and spray head until *after* all flushing is complete and pure water is the only media that will be passing through the system. Damage to the valve assembly or spray head caused by harsh chemicals or debris will not be covered by the manufacturer's warranty.

# Installation notice!

Check Rough-In location **PRIOR** to installation

Flush lines thoroughly **PRIOR** to hook-up

# Physical Dimensions- CWSSS-1\*

\*Shown with optional knee-activated liquid soap dispensers

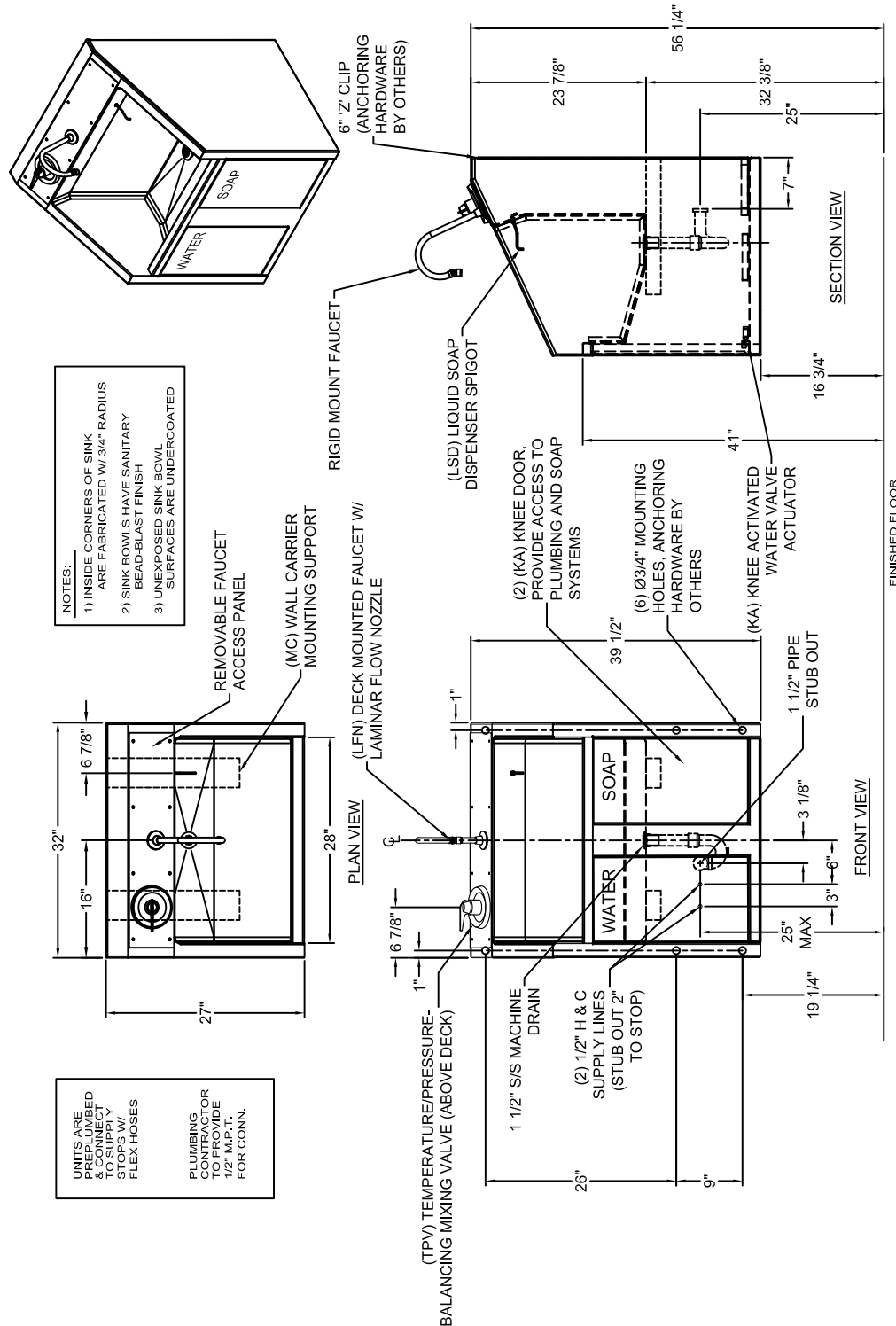

# Rough-in Dimensions- CWSSS-1\*\*

## ONE-STATION

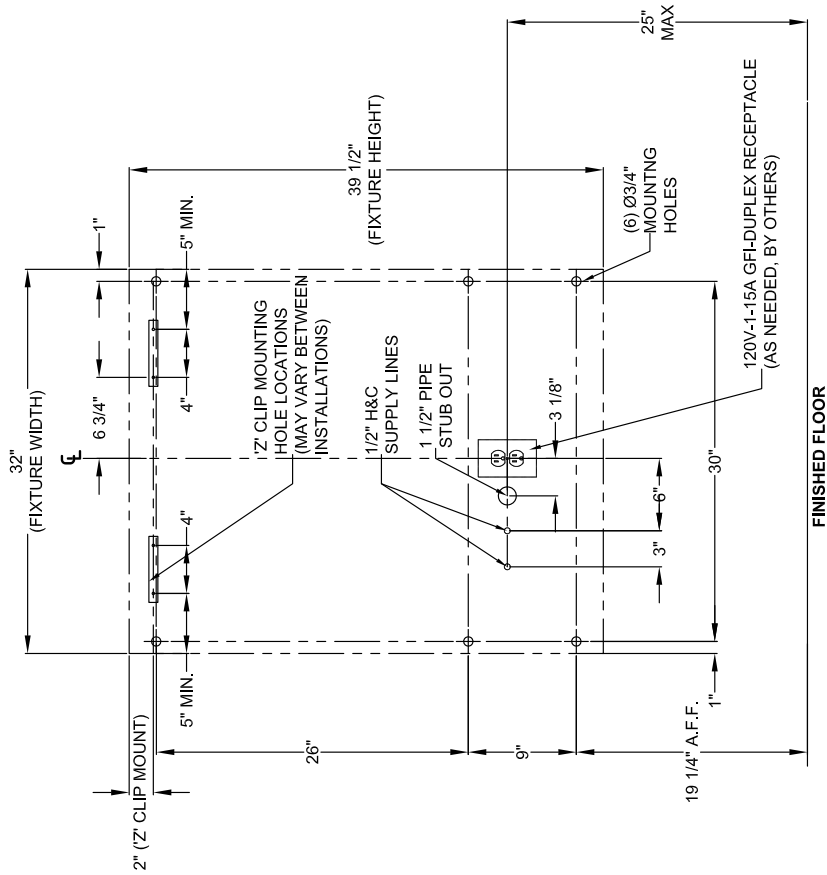

**\*\*GFCI power receptacles are shown for positioning. Depending on options and factory wiring installation, fixture may not require all GFCI receptacles shown here. Consult factory on fixture-specific power needs, if necessary.**

# Physical Dimensions- CWSSS-2\*

\*Shown with optional knee-activated liquid soap dispensers

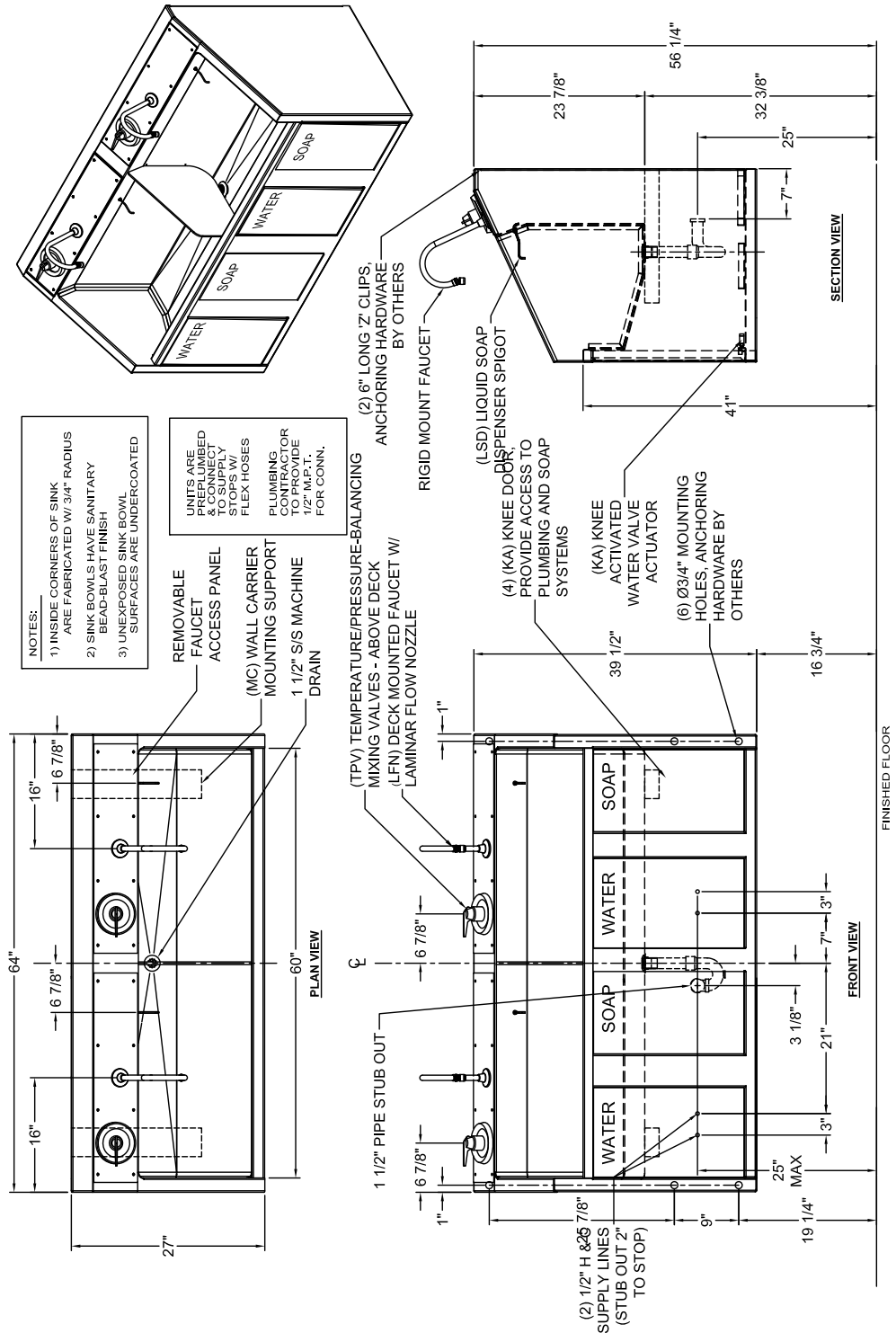

# Rough-in Dimensions- CWSSS-2\*\*

## TWO-STATION

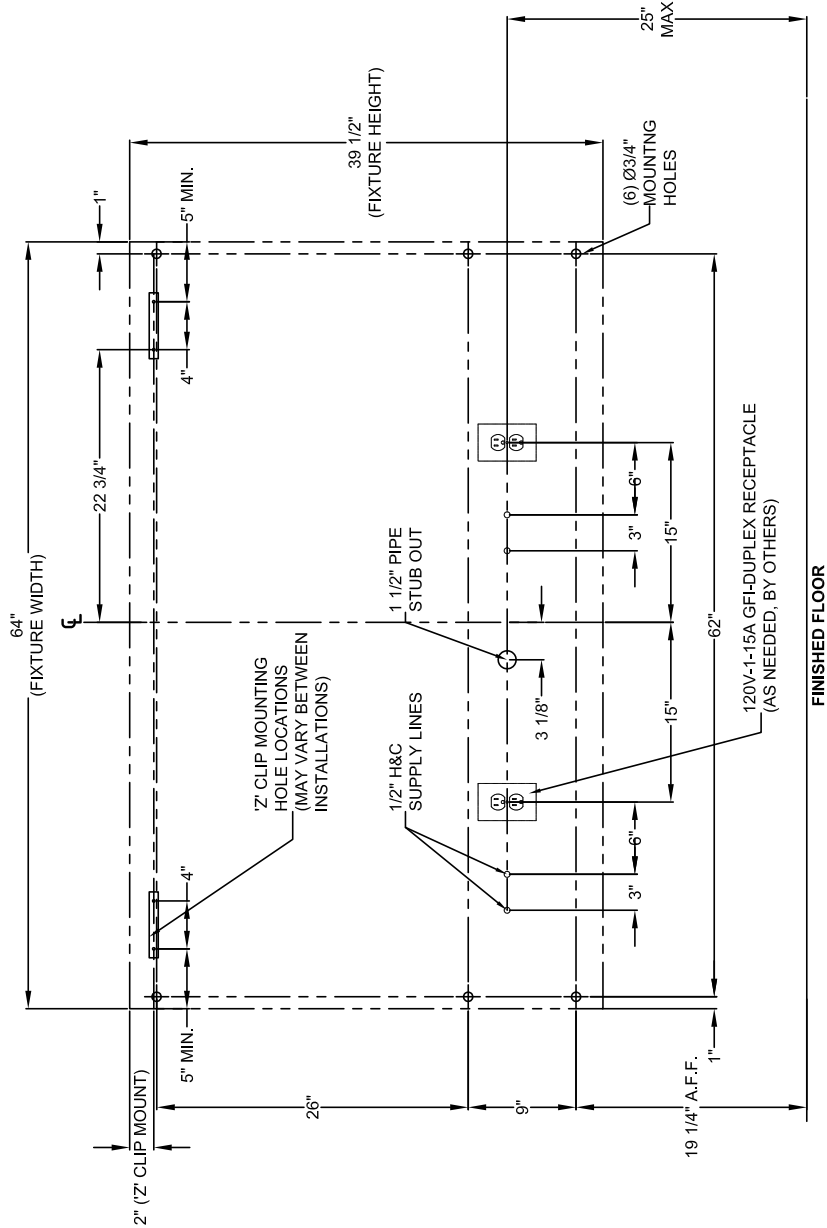

**\*\*GFCI power receptacles are shown for positioning. Depending on options and factory wiring installation, fixture may not require all GFCI receptacles shown here. Consult factory on fixture-specific power needs, if necessary.**

# Physical Dimensions- CWSSS-3\*

\*Shown with optional knee-activated liquid soap dispensers

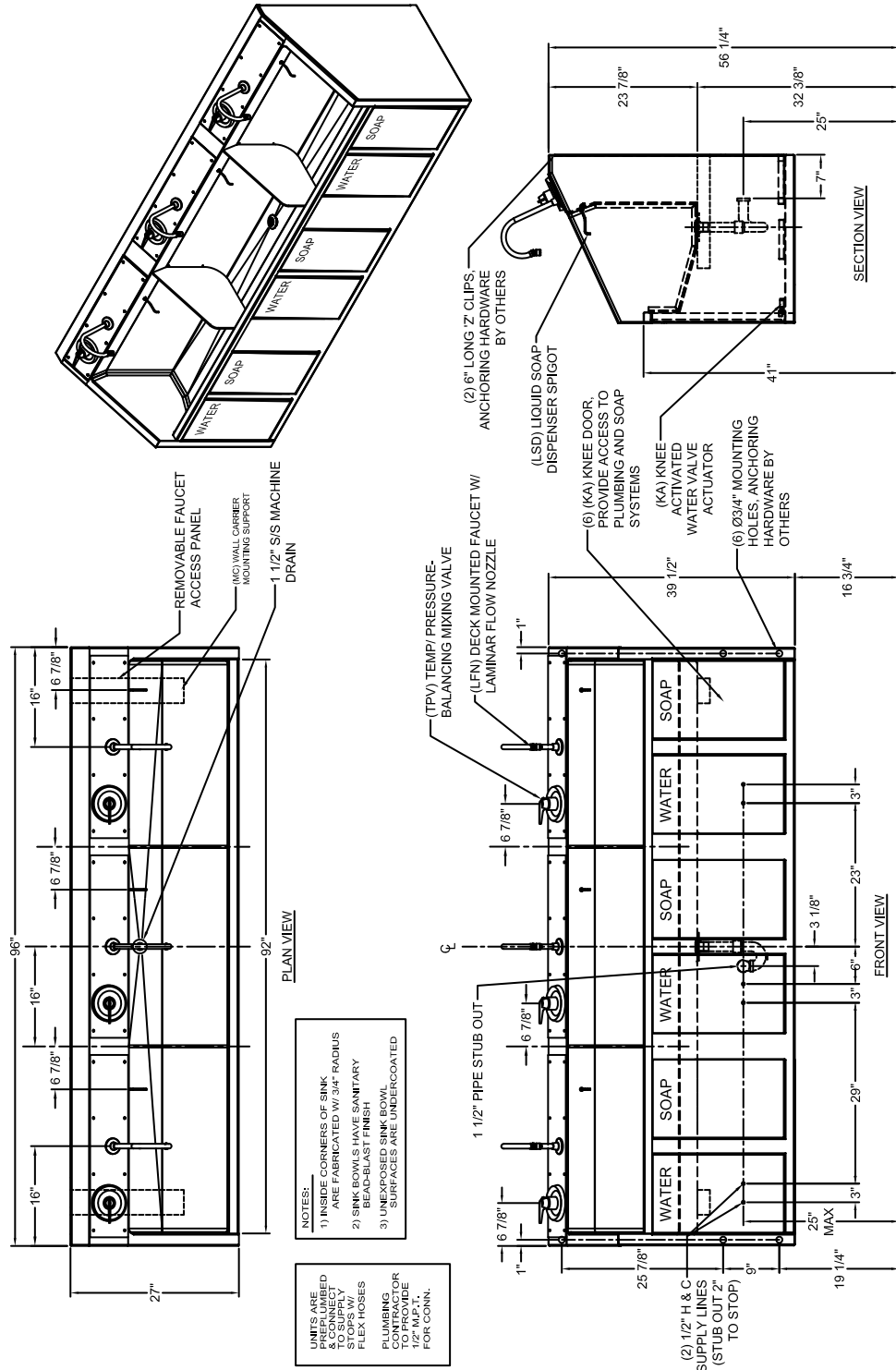

# Rough-in Dimensions- CWSSS-3\*\*

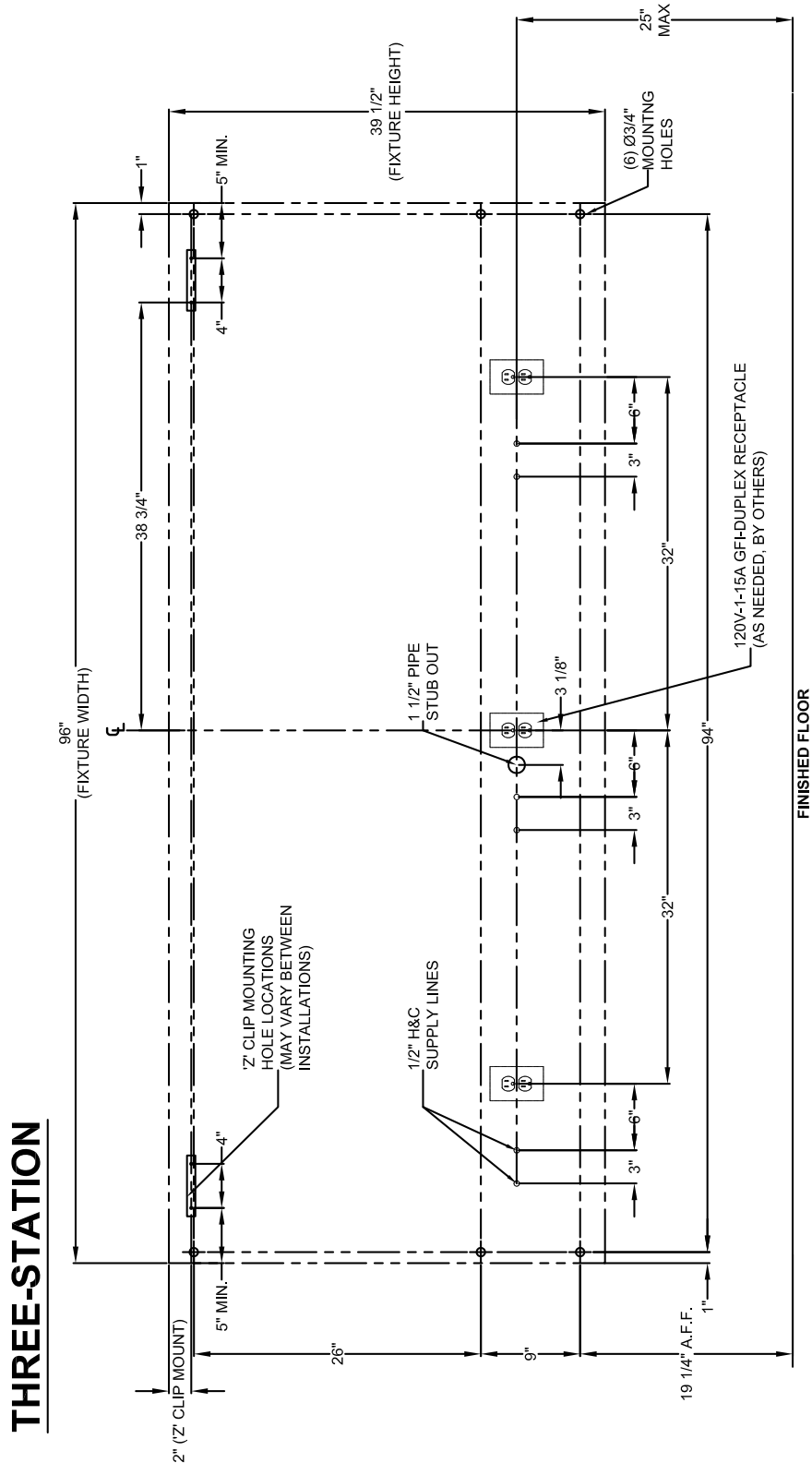

**\*\*GFCI power receptacles are shown for positioning. Depending on options and factory wiring installation, fixture may not require all GFCI receptacles shown here. Consult factory on fixture-specific power needs, if necessary.**

# Parts List

#	DESCRIPTION	WILLOUGHBY PART #s BY MODEL		
		CWSSS-1	CWSSS-2	CWSSS-3
1	SCRUB SINK FIXTURE ASSEMBLY	S700046	S700047	S700048
2	(MC) WALL CARRIER ASSEMBLY	S700082	S700083	S700084
3	(MB) MOUNTING BASE ASSEMBLY	S700269	S700212	N/A
4	FRONT ACCESS PANEL- FOR (IR)	S700229		
5	FAUCET ACCESS PANEL W/ (T/P) (SHOWN)	S700296		
	FAUCET ACCESS PANEL W/ (T/P) & (DTD)	S700300		
	FAUCET ACCESS PANEL W/ (T/P), (DTD), (SDEW)	S700294		
6	(KA) KNEE-ACTIVATED DOOR ASMB (SHOWN)	S700171 (SPECIFY "WATER" OR "SOAP")		
	(KA) KNEE-ACTIVATED DOOR ASMB, DUAL			
	(LSD) KNEE-ACTIVATED SOAP DOOR ASMB.			
7	(KA) HIGHLAND LABS VALVE ACTUATOR	700339LF		
8	(KA) VALVE ACTUATOR MOUNTING BRACKET	S700081		
9	(IR) INFRARED SENSOR ASSEMBLY	701341		
10	S/S DRAIN ASSEMBLY, FLAT STRAINER	320001		
11	(TMV) ADJUSTABLE MIXING VALVE	700480ELF (SPECIFY USE, IE: "FAUCET SUPPLY")		
12	GOOSENECK FAUCET, SCRUB SINK	320421		
	W/ (LFN) LAMINAR FLOW NOZZLE, FAUCET	900205		
13	(TPV) TEMPERATURE/PRESSURE MIXING VALVE	700720		
14	(LSD) LIQUID SOAP DISPENSER- SPIGOT	600302		
15	(LSD) LIQUID SOAP DISPENSER- PUMP			
NOT SHOWN	(LSD) LIQUID SOAP DISPENSER- BOTTLE	800603		
	(LSD) PUMP- MOUNTING BRACKET	S700100		
	(PB) PRESSURE-BALANCING MIXING VALVE	P902G		
	(SDEW) SWING DOWN EYE WASH STATION	G1848		
	VALVE ASSEMBLY, ELECTRONIC	600957 ((T/P) <u>OR</u> (PB) EQUIPPED MODELS)		
		803105-1EW ((TMV) EQUIPPED MODELS)		
	(DTD) DIGITAL TIME DISPLAY	970000N		
	P-TRAP W/ EXTENSION TUBE	380287		
'Z' CLIPS, 6"	800005			

# Exploded-view Drawing

\*CWSSS-1 shown, CWSSS-2 and CWSSS-3 are similar in configuration. See Parts List for model Part # variations.

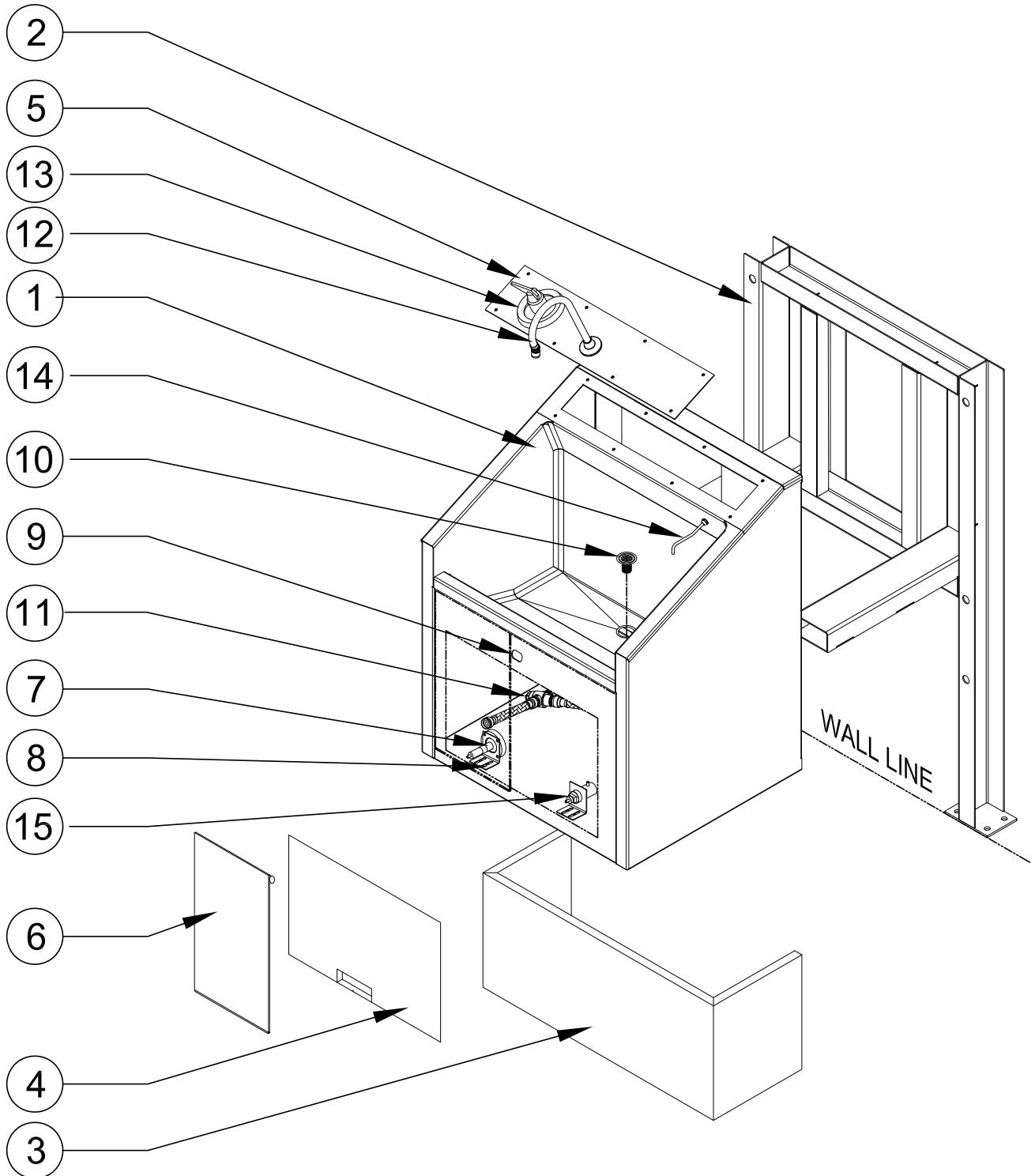

# Hardware Identification

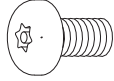

1/4-20 x 1/2"  
SECURITY SCREW  
4500NSS

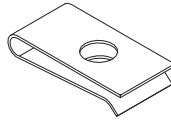

1/4-20  
TINNERMAN NUT  
800113

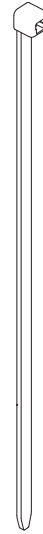

4" WIRE TIE  
800117

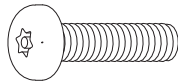

1/4-20 x 1"  
SECURITY SCREW  
800114

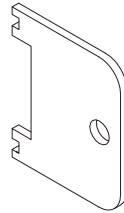

SECURITY  
SPANNER TOOL  
800116

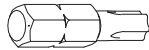

T27  
1/4" PINNED TORX BIT  
800115

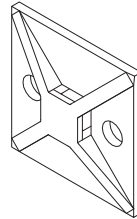

4-WAY  
WIRE TIE BASE  
701206

## **Required Installation Supplies**

- Proper mounting hardware
- Hardware for waste outlet connections
- Gasket for waste outlet connection
- Shims (for installation if necessary)
- Supply piping
- Silicone caulk
- Plumbers putty

**WARNING: Willoughby Industries does not assume any responsibility for personal injury or damage to equipment due to an improperly installed CWSSS Series Scrub Sink.**

# **Installation Instructions**

## **Step 1: Unpacking the Fixture**

### **Parts supplied:**

- Scrub Sink fixture (partially assembled)
- Wall carrier assembly (MC, pre-assembled)  
or
- Mounting base assembly (MB, pre-assembled with fixture)

- 1.) Fixtures will be typically be shipped partially assembled for installation. Upon receiving the fixture, remove the packing material from the assembly and inspect all parts for damage.
- 2.) If you have a wall carrier assembly, separate the fixture from the wall carrier assembly, and set the fixture aside.
- 3.) Position the wall carrier assembly or mounting base assembly within the fixture's specified location:

**If installing a wall carrier assembly (MC), go to Step 2.**

**If installing a floor mounting base assembly (MB), go to Step 3.**

**If installing the fixture without a carrier (MC) or mounting base (MB), go to Step 3.**

# Installation Instructions

## Step 2: Installing the Wall Carrier Assembly (MC)

### Parts supplied:

- Wall carrier assembly (pre-assembled)

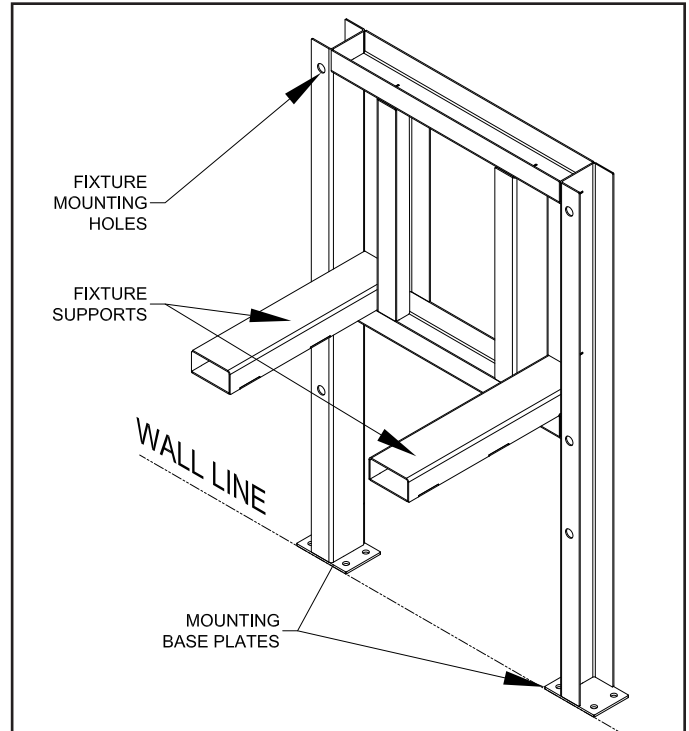

- 1.) Position the wall carrier assembly within the fixtures specified location.  
*Make sure that the intended location will provide adequate support to enable the carrier to safely support the installed fixture within the wall structure. If adequate backing does not exist where the carrier assembly's base plates are located, install appropriate support or relocate unit before proceeding with installation* (adequate backing for carrier mounting by others).
- 2.) Install the carrier assembly through the mounting base plates using anchors that are adequate for the floor type (anchors by others). Carrier can also be welded in place depending on installation parameters. (Suitable weld installation is the responsibility of the installer; it is the manufacturers recommendation that the carrier assembly is anchored through the base plates in all instances to ensure assembly performs as designed.)

**NOTE: Be sure the carrier assembly fixture supports are level to ensure proper draining.**

**NOTE: If finishing the wall at this time (i.e. drywall, sheathing, etc.), make sure to keep the mounting holes on the carrier assembly uncovered. Holes are threaded and could be damaged if drilled.**

- 3.) Once wall carrier assembly is properly installed, go to Step 3 to install the 'Z' clips (if required).

# **Installation Instructions**

## **Step 3: Installing the Fixture 'Z' Clips and Anchors**

### **Parts supplied:**

- Scrub Sink fixture 'Z' clips (if required)
- 'Z' clip anchors (by others)

***NOTE: The included 'Z' clips are meant to be installed on a finished wall (i.e. drywall, sheathing, etc.) or the surface that the fixture back will be in contact with after installation. Make sure that the intended location will provide adequate support to enable the 'Z' clip anchors to safely support the installed fixture. (anchors and adequate backing by others)***

- 1.) Locate the 'Z' clip positions using rough-in details specific to the installed fixture (see *Physical / Rough-in Dimensions on Pages 4-9*).
- 2.) Install 'Z' clips using appropriate wall anchors (wall anchors by others).

***NOTE: Be sure the 'Z' clips are level to ensure proper fixture draining.***

- 3.) Locate the (6) 3/4" Dia. mounting holes for the fixture using rough-in details specific to the installed fixture (see *Physical / Rough-in Dimensions on Pages 4-9*).
- 4.) Install appropriate wall anchors to securely mount the fixture (wall anchors by others).

***NOTE: Be sure the anchor locations are level to ensure proper fixture draining once fixture is mounted.***

# Installation Instructions (cont.)

## Step 4: Fixture Preparation

### Parts supplied:

- Scrub Sink fixture (partially assembled)

- 1.) Place the fixture on level ground.
- 2.) If you have a Knee-Activated (KA) sink, remove the Door Assembly:
  - 2a.) The door is hinged at the top; to open, push in gently and release; the door should rebound to you. If the door is stuck, use a non-marring material (wood/composite shim, rubber spatula, credit card, etc.) to carefully pry the door open from the bottom.
  - 2b.) Once the door is away from the fixture, reach through the opening and lift the hinged catch on the bottom of the door and open until resistance is felt.
  - 2c.) To remove, reach up to the top if the Door Assembly from the inside. At the upper corners are two spring-latches. Slide the latch pins towards the center of the Door Assembly to release and remove the door.
- 3.) If you have an Infrared Actuated (IR) sink, remove the Front Access Panel:
  - 3a.) Unscrew the security screws for the front access panel. Screws are located above the panel (*see upper diagram*).
  - 3b.) Once the panel is free, lift the panel up and outward, and slide down to remove. Set aside. Make sure to retain the screws and tinnerman nuts for reassembly.
- 4.) If you have a two- or three-station sink, repeat step 2 or 3 to remove the front access panels at each station.
- 5.) Remove the faucet access panel(s) located on the top of the fixture, making sure to disconnect the faucet from the water supply line. Set aside for later reassembly.

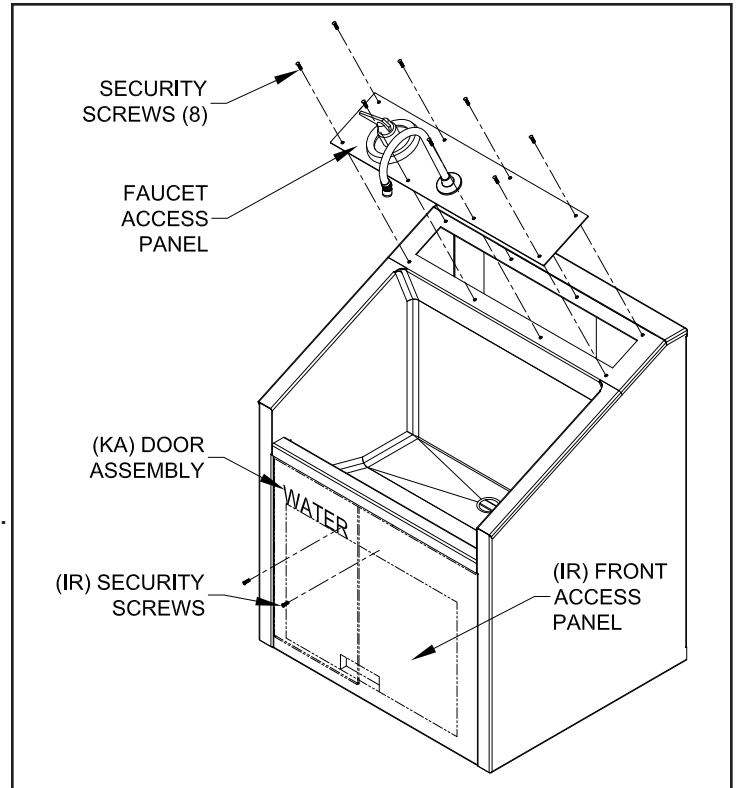

**One-station fixture shown, both (KA) and (IR) panels**

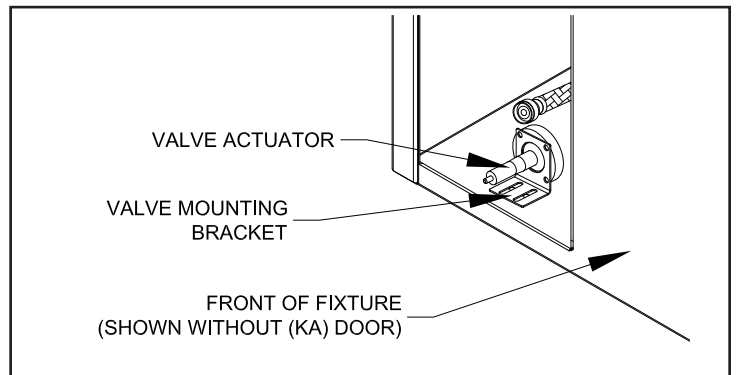

**(KA) valve actuator shown, (KA) models only**

## Installation Instructions (cont.)

### Step 5: Drain Assembly

**Parts supplied:**

- Scrub Sink fixture
- Drain assembly (see diagram)

**NOTE: If installing a two- or three-station sink, remove the divider panel(s) before drain assembly installation.**

- 1.) Insert the drain basket down through the sink drain hole.
- 2.) Secure in place by fitting the rubber washer and drain cup around the drain basket from the underside of the sink. Tighten the locknut onto the drain basket, sandwiching the washer between the sink and drain cup.

**Note: Over-tightening can damage the basin and/or drain assembly components**

- 3.) The fixture is ready for plumbing and electrical installation:

**If you have (IR) infrared actuated faucet(s), go to Step 4A.**

**If you have (KA) knee-activated faucet(s), go to Step 4B.**

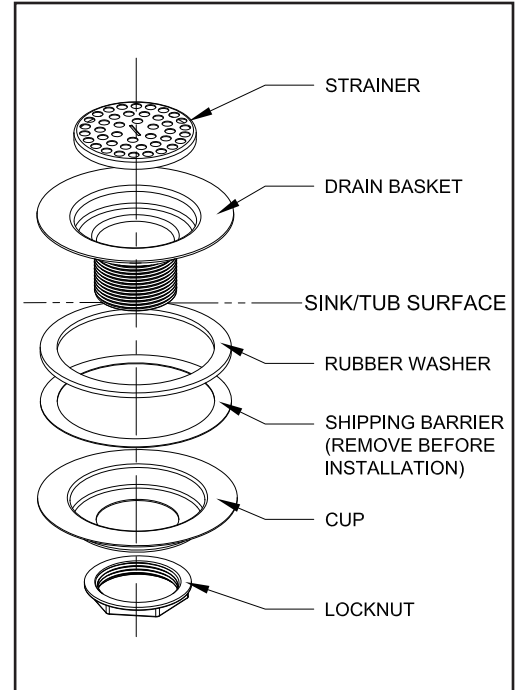

**Drain Assembly #320001**

## Installation Instructions (cont.)

### Step 6A: Connections for (IR) Infrared Actuators

#### Parts supplied:

- Valve assembly (pre-installed)
- (IR) infrared sensor
- Sensor wiring assembly (pre-assembled w/ 24V transformer)
- (T/P), (TMV), or (PB) mixing valve
- Faucet water supply lines
- H&C water supply flex hoses
- Security screws

**Note:** Use wire tie mounts and wire ties to route and secure wiring. Wires are long enough to accommodate various routing paths. Longer tubes may need to be bundled with wire ties so they do not come in contact with sharp corners.

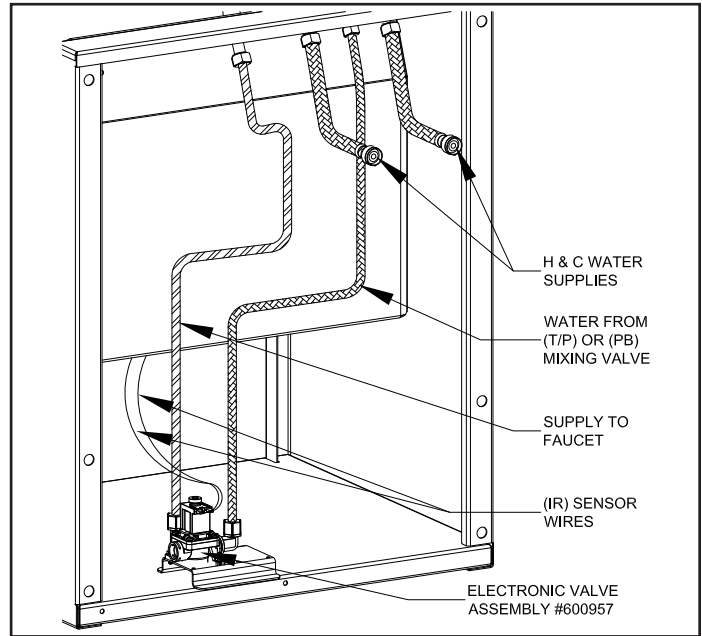

**(IR) with (T/P) sink station setup, shown from wall-side**

- 1.) Locate the infrared sensor. Attach the sensor inside the front of the sink assembly using appropriate mounting screws, making sure that the sensor window is oriented and positioned correctly behind the sensor hole to ensure proper operation.
- 2.) Plug the colored wires coming from the sensor wiring assembly onto the mounted infrared sensor as shown on the [\(IR\) Infrared Sensor Installation Instructions page](#).
- 3.) Attach the dark-colored wire harness plugs to the contacts on the blue solenoid on the electronic valve assembly (pre-installed in the fixture). Attach the light-colored wire harness contacts to the 24V transformer; do not plug-in transformer at this time.

**NOTE:** If installing a two- or three-station fixture, wire colors and routing may vary

- 4.) If installing a model with a (T/P) (*Standard on CWSSS*), (TMV), or (PB) mixing valve, connect the hot and cold water supply flex hoses to the mixing valve per valve installation instructions, then connect the valve outlet to the valve assembly inlet using an included brass elbow and mixing valve adapter. Secure the adapter to the inlet using a collar pin.
- 5.) Connect the faucet supply line to the valve assembly outlet using an included brass elbow and mixing valve adapter. Retighten the nut to secure the water line in the elbow. Secure the adapter to the outlet using a collar pin.
- 6.) Repeat steps 1-5 as needed for remaining stations, if installing a two- or three-station fixture.

## Installation Instructions (cont.)

### Step 6B: Connections for (KA) Knee-activated Actuators

**Parts supplied:**

- Valve assembly (pre-installed)
- Hydraulic valve actuator
- Security screws
- Faucet water supply lines
- H&C water supply flex hoses
- Adjustable mixing valve
- Security screws

**Note: Use wire tie mounts and wire ties to route and secure tubing. Tubes and supply lines are long enough to accommodate various routing paths. Longer tubes may need to be bundled with wire ties so they do not come in contact with sharp corners.**

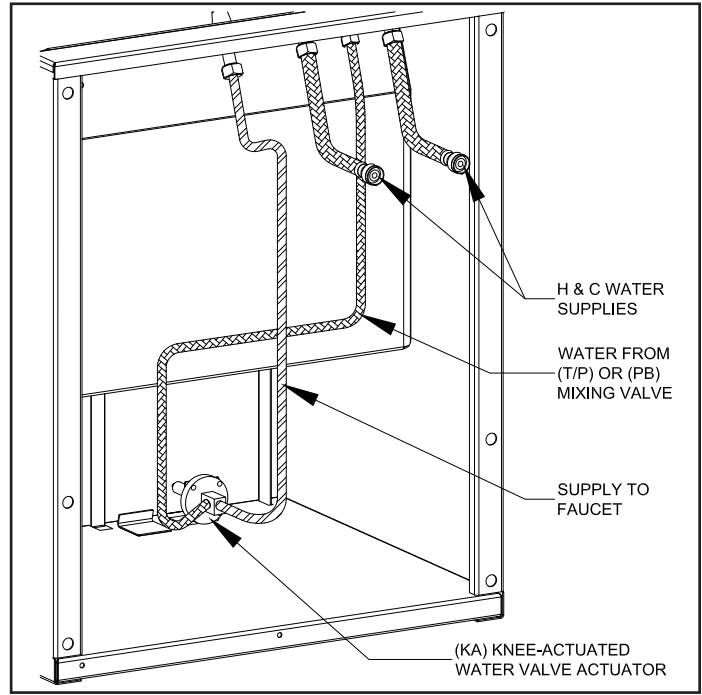

**(KA) sink station setup, non-PB, shown from wall-side**

- 1.) Locate the (KA) knee-activated valve actuator.
- 2.) If installing a model with a thermostatic mixing valve, connect the hot and cold water supply flex hoses to the thermostatic mixing valve, then connect the valve outlet to the valve actuator inlet (side) with an additional flex hose.
- 3.) Connect the faucet supply line to the valve actuator outlet (rear). Use the included valve actuator instructions for reference (see the **Manufacturers Appendix** at the end of this manual).
- 4.) Make sure the valve actuator assembly and adjustable mixing valve are secured to the fixture.
- 5.) If installing a two- or three-station fixture, repeat steps 1-4 for each remaining station.

## Installation Instructions (cont.)

### Step 7: Mounting the Fixture Assembly

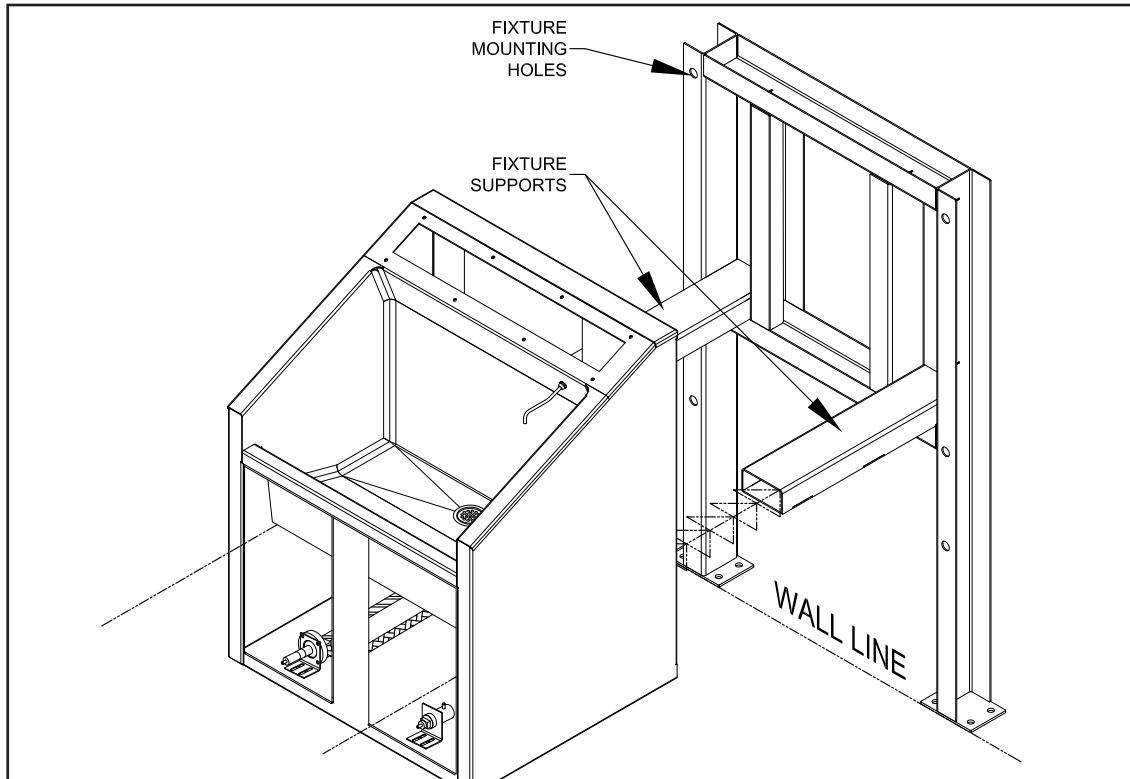

#### Parts supplied:

- Fixture assembly (prepared in Steps 4, 5, & 6A or 6B)
- Wall carrier assembly (if installed)
- Mounting bolts

**Caution: Do not leave the fixture unsupported while mounting, as it may fall and cause damage or personal injury.**

- 1.) With the help of an assistant, lift the fixture and slide it up and over the 'Z' clips, and wall carrier fixture supports if needed, making sure to align the holes in the back of the fixture with the wall anchor holes or mounting holes in the wall carrier.
- 2.) While an assistant supports the fixture, bolt the fixture to the wall anchor holes or mounting holes in the wall carrier depending on the installation. Use the openings on the front and top of the fixture to access the hole locations. **Do not fully tighten bolts yet.**
- 3.) Check to make sure fixture is level front-to-back and side-to-side to ensure proper drainage. Fully tighten bolts to secure the fixture once in-place and level.

## **Installation Instructions (cont.)**

### **Step 8: Final Assembly**

#### **Parts supplied:**

- Faucet access panel
- Front access panel or knee-activated door assembly on (KA) model)

**NOTE: BEFORE MAKING FINAL CONNECTIONS, MAKE SURE THAT THE SYSTEM HAS BEEN PROPERLY FLUSHED AS DETAILED IN THE PRE-INSTALLATION INSTRUCTIONS.**

- 1.) If you have an optional digital timing display (DTD), install and setup the unit at this time per the digital timer manufacturers' installation instructions (*see the **Manufacturers Appendix** at the end of this manual for instructions*). Attach the LCD timer to the faucet access panel.
- 2.) If you have an optional liquid soap dispenser system (LSD), install the unit at this time per liquid soap pump manufacturers' installation instructions (*see the **Manufacturers Appendix** at the end of this manual for instructions*). Install the factory supplied soap spigot on the fixture at this time if it has not yet been installed.
- 3.) Feed the faucet water supply tube up through the top access in the fixture, and connect to the faucet. Re-attach the faucet to the faucet access panel (if needed).
- 4.) Replace the faucet access panel and secure using the included security screws.
- 5.) Make all final plumbing connections to valve inlets using supplied flex hoses (flex hoses have shut-off valves attached that should be connected to the supply inlets).
- 6.) If installing an (IR) fixture, plug-in the transformer. Infrared sensor is self-calibrating; see (IR) Infrared Sensor Installation Instructions page for further details.

**NOTE: PLUG-IN TRANSFORMER (IF NEEDED) MUST BE USED WITH A GROUND FAULT INTERRUPT (GFCI) RECEPTACLE TO HELP PREVENT POSSIBLE ELECTRICAL SHOCK.**

- 7.) If you have a Knee-Activated (KA) and/or (LSD) sink, adjust the position of the valve mounting bracket to ensure that the (KA) door and/or (LSD) door effectively activates the actuator with the least amount of travel. Use the included valve actuator instructions for reference.
- 8.) Make final adjustments to valves and supply lines as needed and replace the front access cover or knee door(s) using the included security screws and tinnerman nuts.
- 9.) Replace the divider panel(s) in the sink, if necessary.

# (TPV) Temp./Pressure Mixing Valve Installation

Ile700CR

**POWERS™**

**HydroGuard® T/P**  
Series e700

## INSTALLATION INSTRUCTIONS Cartridge Replacement

### e700 CARTRIDGE REPLACEMENT INSTRUCTIONS

The following instructions explain how to replace the cartridge to your Series e700 valves:

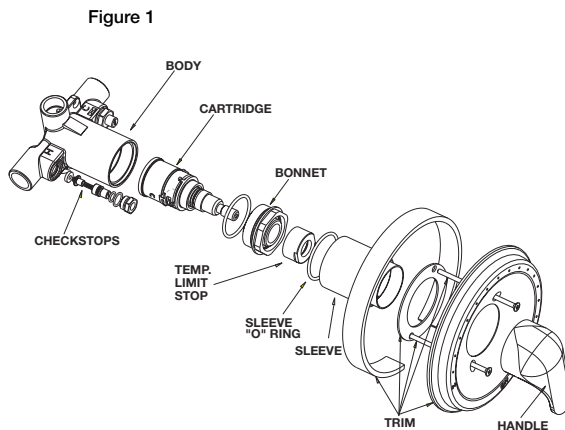

#### Disassembly:

1. Turn off hot & cold water supply-stops.
2. Remove the handle and trim plate.
3. Remove bonnet.
4. Remove all internal components from the valve body.
5. At this point you should have an empty valve body.

You are now ready to put the new cartridge into your existing valve.

#### CALIFORNIA PROPOSITION 65 WARNING

**WARNING:** This product contains chemicals known to the State of California to cause cancer and birth defects or other reproductive harm. (California law requires this warning to be given to customers in the State of California.)

For more information: [www.watts.com/prop65](http://www.watts.com/prop65)

#### Reassembly:

1. Ensure the inside of the valve body is free of deposits and debris. Clean as necessary.
2. Place the cartridge into the body ensuring following:
  - a) "C" on the cartridge should be on the cold inlet side.
  - b) Align tab on the back of the cartridge to the groove in the body.
3. While holding cartridge firmly, screw bonnet into body; tighten to 100 + 20/-0 in-lbs.
4. Turn the hot and cold water supplies back on and verify there is no leakage.

#### Maximum Temperature Setting/Handle Rotation Stop

The handle rotation setting must be adjusted to limit the distance the user can rotate the handle towards the full hot water position.

**CAUTION:** Any repair or modification of the valve may affect the high temperature setting. The maximum temperature setting must be checked by the installer before use.

5. Adjust the valve to the desired maximum outlet temperature [110°F (43°C) max]. Screw on the high temp. limit stop until it touches the stem shoulder.
  6. Turn the stem clockwise until the water stops. Open valve to full hot position and verify max outlet temperature setting.
  7. (a) For e707
    1. Install the trim plate.
    2. Snap-on the indicator plate. Guide on the back of the plate goes into the locator hole.
    3. Install O-ring on the bonnet, slide sleeve on the bonnet.
    4. Install handle and tighten the set screw.
- CAUTION:** Indicator plate must be installed before sleeve.
7. (b) For e705 & e710  
Place sleeve O-ring on the bonnet shoulder. Slide sleeve over the O-ring until it stops and replace trim plate and handle.

If you have any problems, comments, or suggestions, please contact your Powers representative. We are interested in feedback from the field.

**POWERS™**  
a division of Watts Water Technologies, Inc.

© 2006 Powers

USA: Phone: 1.800.669.5430 • Fax 1.847.229.0526 • [www.powerscontrols.com](http://www.powerscontrols.com)  
Canada: Phone: 1.888.208.8927 • Fax 1.888.882.1979 • [www.powerscontrols.ca](http://www.powerscontrols.ca)

Ile700CR 0632

EDP# 6511200

# (TMV) Thermostatic Mixing Valve Installation

**POWERS™**

IS-P-e480

**HydroGuard® T/P Series e480  
Lavatory Combination Valve**

## Installation Instructions

### To Install ■

**NOTE:** Installation should be in accordance with accepted plumbing practices. Flush all piping thoroughly before installation.

1. Locate a suitable place for the tempering valve. Valve should be accessible for service and adjustment and as close to the point-of-use as possible.
2. Connect hot and cold water to the supply valve using 1/2" NPT or 3/8" compression connections.
3. Connect outlet of tempering valve to fixture(s) using 1/2" NPT or 3/8" compression connections.
4. Turn on hot and cold water supplies. If any leaks are observed, tighten connections as necessary to stop leaks before proceeding.
5. Turn on fixture and allow water to flow for 2 minutes. Measure water temperature at outlet. If water is not at desired temperature, adjust as necessary.

### Specifications ■

e480-00	.....1/2" NPT (Rough Bronze)
e480-01	.....1/2" NPT (Rough Chrome)
e480-10	.....3/8" Compression (Rough Bronze)
e480-11	.....3/8" Compression (Rough Chrome)
Capacity:	..... 4.0 gpm (15.0 l/m)
Approach Temperature:	.....5°F (2.8°C) above set pt.
Max. Operating Pressure:	..... 125psi (862 kpa)
Max. Static Pressure:	..... 125psi (862 kpa)
Max. Hot Water Temperature:	..... 180°F (82°C)
Temp. Adjustment Range:	
.....	ASSE Type T/P: 95 – 110°F (43-48°C)
.....	ASSE Type T: 80 – 120°F (27-49°C)
Minimum Flow:	..... 0.5 gpm (2.2 l/m)
Checks:	..... Integral
Construction:	..... Cast Brass Body
Certified:	..... CSA B125
Listing	.....ASSE 1016-1996 (Type T/P)
.....	.....ASSE 1070

#### CALIFORNIA PROPOSITION 65 WARNING

**WARNING:** This product contains chemicals known to the State of California to cause cancer and birth defects or other reproductive harm. (California law requires this warning to be given to customers in the State of California.)

For more information: [www.watts.com/prop65](http://www.watts.com/prop65)

Figure 1

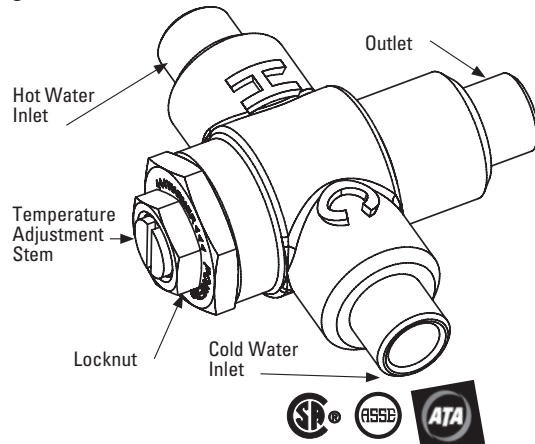
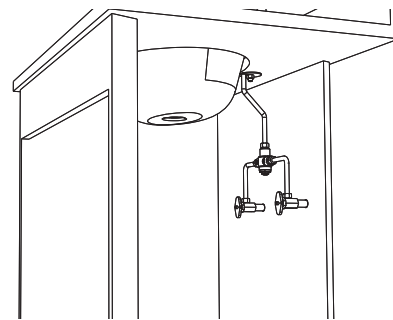

Figure 2: Typical Installation



### To Adjust Temperature ■

1. Loosen locknut.
2. Turn on fixture and run water for at least two (2) minutes to allow supply temperature to stabilize.
3. Turn temperature stem counter-clockwise for hotter or clockwise for colder outlet temperature.
4. Tighten locknut to prevent accidental or unauthorized temperature adjustment.
5. Re-check outlet temperature.

### Repair Kit ■

Motor Repair Kit.....480-270

# (IR) Infrared Sensor Installation Instructions

**SLOAN**<sup>®</sup>

Code No. 0816196  
Rev. 2 (11/11)

## OPTIMA<sup>®</sup> SENSOR REPLACEMENT KIT INSTALLATION INSTRUCTIONS

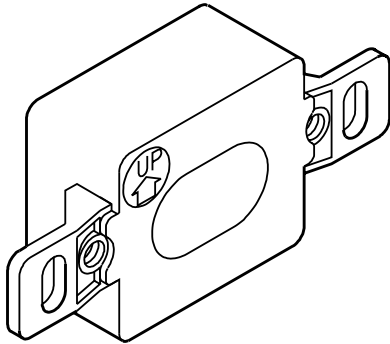

**EL-1500-LL  
Lavatory Sensor**

### Lavatories (EL-1500-LL Sensor)

When the sensor detects a user, a slow flashing red light appears in the sensor window. After one (1) second, the light flashes rapidly and the sensor immediately activates the solenoid valve to begin water flow.

The solenoid valve remains open as long as the user is detected. The solenoid valve turns off after the user is no longer detected for two (2) seconds.

### INSTALLATION AND REPLACEMENT

1. Disconnect 24 VAC power supply at the transformer or fuse box.
2. Remove the cover plate and old sensor from the wall installation. Use a hex wrench to remove the cover plate.
3. Connect one 24 VAC lead to the sensor terminal labeled "24 VAC IN." (See Fig. 2)
4. Connect one solenoid lead to the sensor terminal labeled "TO VALVE." (See Fig. 1)
5. Connect the remaining 24 VAC lead to the remaining solenoid lead.
6. On water closet installations ONLY, connect the override button (shown as Override Switch in Fig. 1 Wiring Diagram) parallel to the EL-1500-L sensor.
7. The illustration of the sensor on the front cover of these installation instructions shows an orientation arrow on the lens side of the sensor. Reinstall the sensor with the arrow pointing UP. Replace the cover plate and tighten the cover plate to the wall.
8. Reconnect the 24 VAC power supply at the transformer or the fuse box.

### SLOAN EL-1500 SERIES SELF-ADAPTIVE OPTIMA SENSOR

The EL-1500 Series Optima Sensor represents the most advanced technology used in any sensor activated plumbing product available today.

### ABOUT SLOAN EL-1500 SERIES OPTIMA SENSORS

The EL-1500 Series Optima Sensor is the first sensor used with a plumbing product that "thinks." An EL-1500 sensor adapts itself to its environment. The sensor self adjusts its own range setting based on what it "sees" in front of it, and therefore needs no manual range adjustment. It automatically compensates for the depth and reflectivity of the opposite wall or stall door and for the ambient lighting conditions of the restroom.

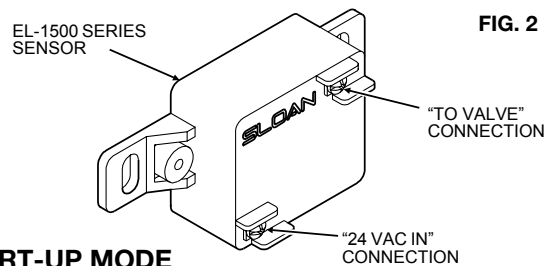

**FIG. 2**

### START-UP MODE

The self-adaptive sensor automatically adapts to the surrounding environment when 24 volt supply is activated. No manual adjustments are required.

Start-up mode will take approximately one (1) minute to complete its cycle and is important that no non-permanent target is present at this time. A continuous red light visible in sensor window indicates sensor is in the start-up mode. If the red light is flashing, this indicates that the sensor is picking up a target. Unless this target is a permanent fixture in the sensor's environment (i.e., wall or stall door), it must be removed from the view of the sensor. Then, either disconnect the 24 volt supply for twenty (20) seconds or more, or push the manual override button for more than twenty (20) seconds in closet set-up. Reconnect the 24 VAC power supply at the transformer or the fuse box. When the start-up cycle is complete, there will be no light visible in the sensor window.

**NOTE: If the 24 volt power supply is ever interrupted for longer than twenty (20) seconds, the start-up mode automatically begins when power is restored.**

Incorrect wiring or a short in the 24 volt power supply is indicated by a continuous warning signal seen in the sensor window. The visible red light flashes an "SOS" signal: three (3) slow, three (3) fast, three (3) slow flashes.

**When further assistance is required, please contact your  
local Sloan Representative or Sloan Technical Support at:  
1-888-SLOAN-14 (1-888-756-2614)  
or visit us online at [www.sloanvalve.com](http://www.sloanvalve.com)**

# **Care and Maintenance**

## **STAINLESS STEEL CARE**

Stainless Steels are basically alloys of iron and chromium and are corrosion resistant. Stainless steel has a bright surface that is easy to clean and is free from oxides. Therefore, cleaning of stainless steel is relatively simple and easy if done on a regular basis.

Frequency of cleaning should depend on the rate at which the fixture becomes dirty. Remember that fresh (soft) deposits of all kinds are relatively easy to remove, while removing older (hard) deposits are much more difficult. Establish a cleaning SCHEDULE.

Routine cleaning should involve ordinary soap or detergent and water, applied with a sponge, brush or cloth. Baking soda, borax or any of several non-abrasive commercial cleansing agents can help hasten the cleaning action. after scrubbing, rinse THOROUGHLY and wipe dry.

DO NOT use common steel wool, scouring pads, scrapers, wire brushes, files or other steel tools to clean stainless steel. Such items will scratch the surface or leave small particles of iron imbedded in the surface, which will eventually rust and stain the surface - even appearing as if the stainless itself was rusting.

Certain chemical compounds, if used on stainless steel, can give the appearance of rust and if allowed to stand for long periods of time, can pit the surface of stainless steel. Products containing hydrochloric acid, muriatic acid or potassium hydrochloride can ruin the surface.

## **Troubleshooting - Infrared Sensors**

- I. Faucet does not function (red light does not appear when user steps in front of sensor)
  - A. No power to sensor. Make certain that power is on. Check transformer leads and connections. Repair or replace as necessary.
  - B. IR Sensor not operating. Replace IR Sensor.
  
- II. Faucet does not function (red light appears when user steps in front of sensor and solenoid does not click)
  - A. Debris in solenoid; disassemble, clean, and flush.
  - B. Solenoid not wired correctly; check solenoid connections.
  - C. Solenoid problem; replace solenoid.
  
- III. No water when activated (valve clicks)
  - A. Make certain that water is turned on.
  - B. Valve clogged. Clean or replace filter.
  
- IV. Very low flow or slow dribble
  - A. Check supply stop(s); open if closed.
  - B. Debris in filter; remove, clean, and reinstall.
  - C. Debris in aerator or spray head; remove, clean and reinstall.
  - D. Disassemble solenoid; clean and flush.
  
- V. Continues to run (with power on and red light flashing)
  - A. Non-permanent target in range after user leaves. Remove non-permanent target. If this target is a new permanent target (i.e., a new wall or partition), turn off 24 volt power for twenty (20) seconds. Turn power back on and let the sensor complete start-up mode.
  - B. Sensor failure; replace sensor.
  
- VI. Continues to run (even with power disconnected)
  - A. Solenoid valve installed backwards.
  - B. Debris in solenoid, won't close properly; remove operator and clean. Reassemble in the same manner.

## **Troubleshooting - Electronic Valves**

The two most common reasons an electronic valve does not operate properly are: (1) lack of power or (2) lack of water pressure. The following steps should be used as a guide in identifying the problem of a malfunctioning electronic valve.

- I. Lack of power
  - A. Verify that the 110V GFCI outlet has power
  - B. Check all connections to ensure they have been made correctly:
    1. Cable connecting the valve coil and the timer or IR sensor
    2. Cable connecting the timer and the pushbutton (Piezo only)
    3. Cable connecting the timing device and the 24VAC transformer
    4. The 24VAC transformer and the 110V GFCI outlet
  - C. If the valve is wired correctly, the solenoid will make a “click” sound indicating that the valve has been actuated. The electronic valve is actuated by either the piezo pushbutton or the triggering of the infrared sensor (see the Start-Up Instructions for Infrared Sensors in this manual).
  
- II. Lack of water pressure
  - A. Check the supply to the rough-ins
  - B. Make sure the screwdriver stops are in the open position
  - C. Water pressure needs to be above 35psi to operate the valve
    1. If the water supply pressure is above 35psi but not exiting the valve:
      - a. Clean any debris from the screen on the inlet side of the solenoid valve body
      - b. Remove the screws on the valve body and clean any debris from the diaphragm

After all of the above steps have been followed, if there is still no water coming out of the spray head, there may be a damaged or defective part (see installation notice in the beginning of this

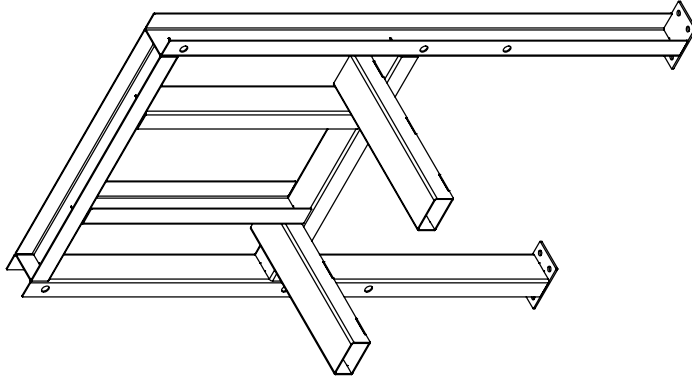

Part Number: W-H4132-0088

Scrub Sink Drawing #: S700046

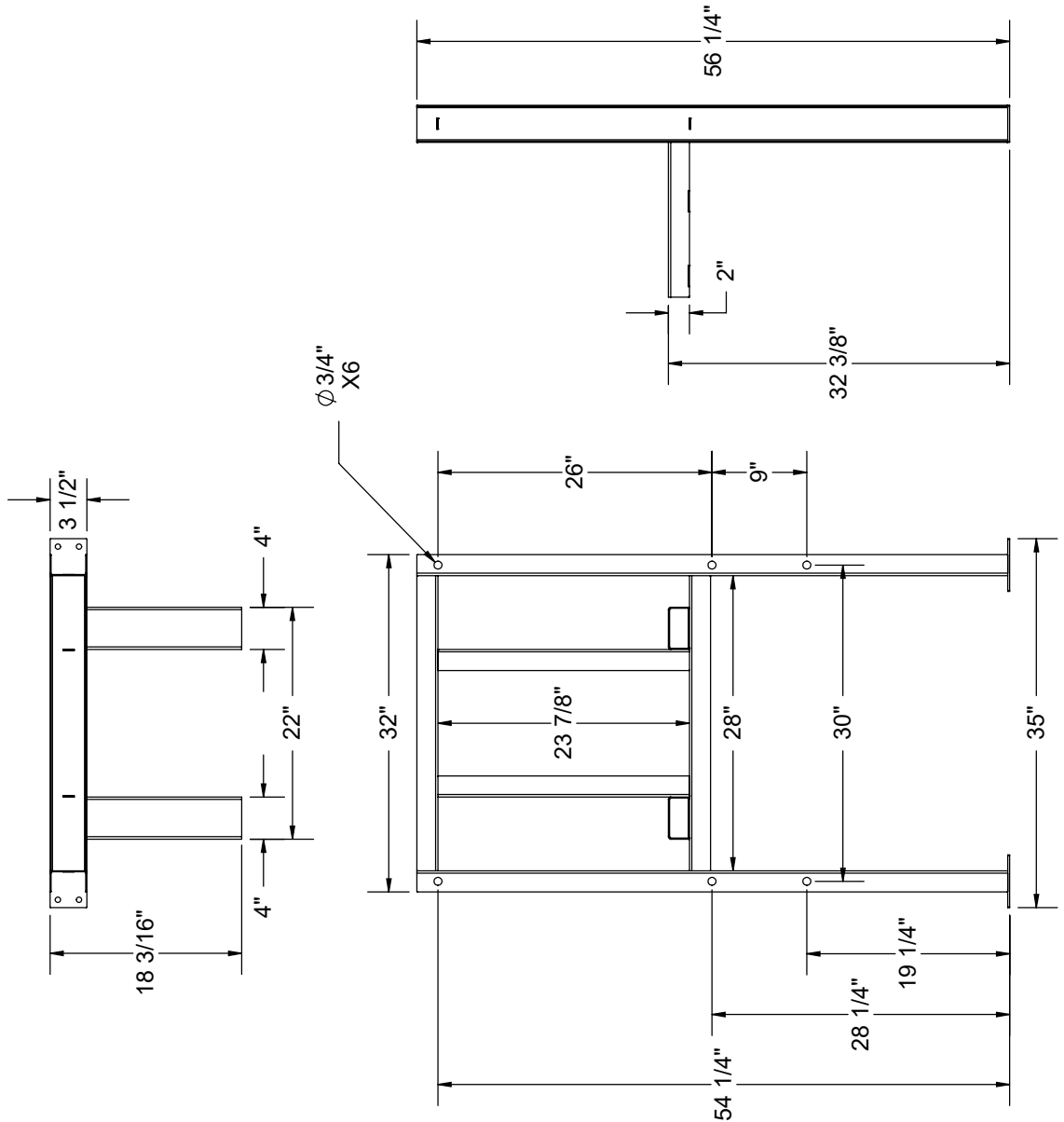

**DRAWING: CWSSS-1 Wall Carrier Detail**

**DRAWING: CWSSS-2 Wall Carrier Detail**

Part Number: W-H4164-0071

Scrub sink Drawing #: S700047

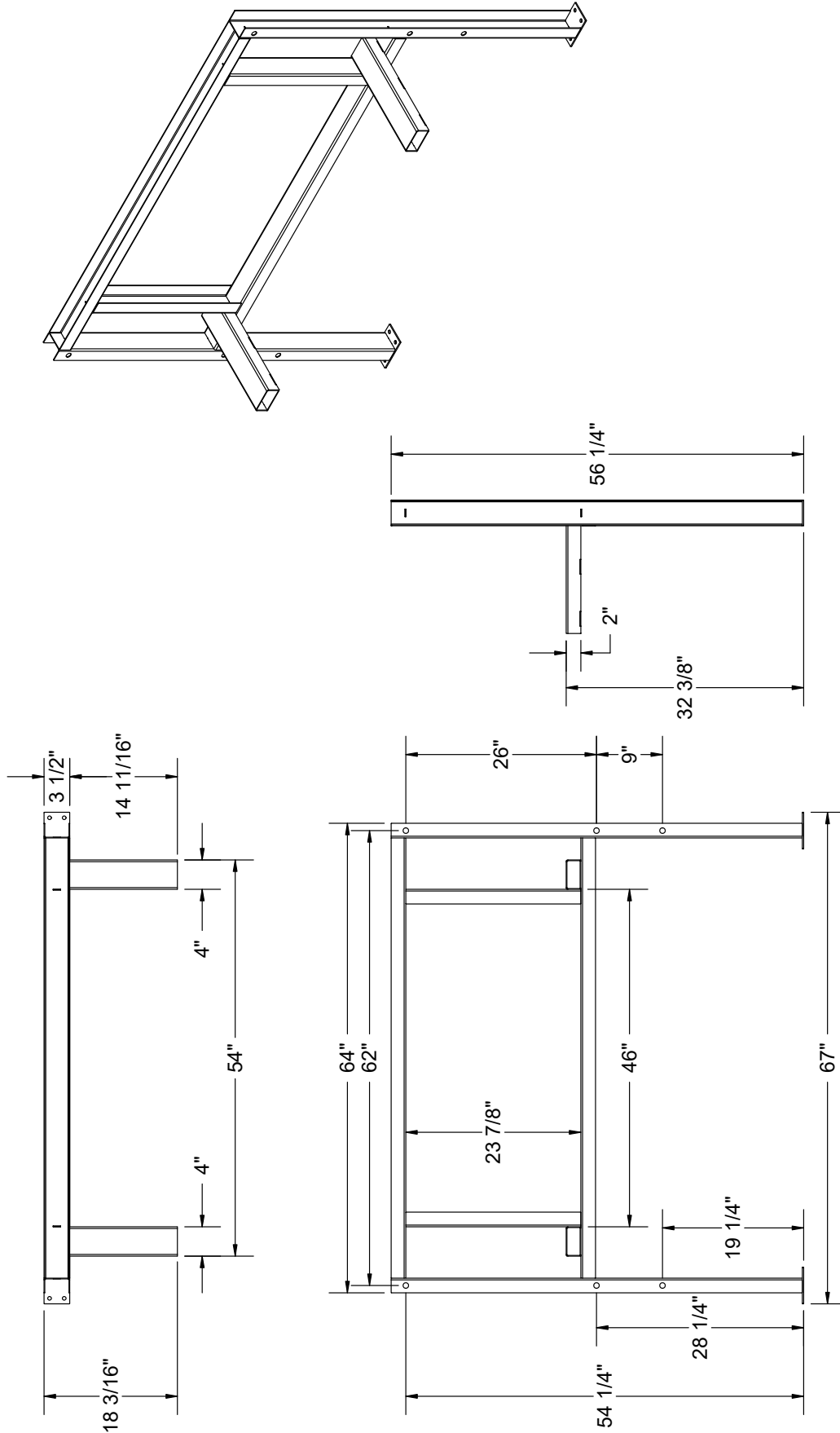

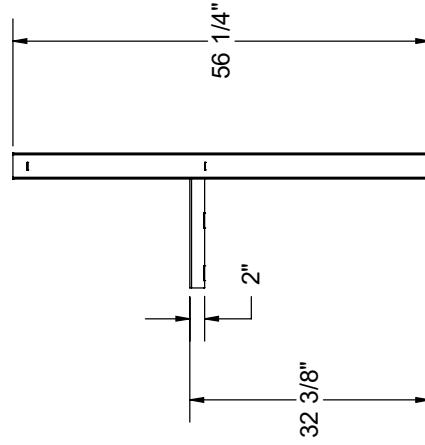
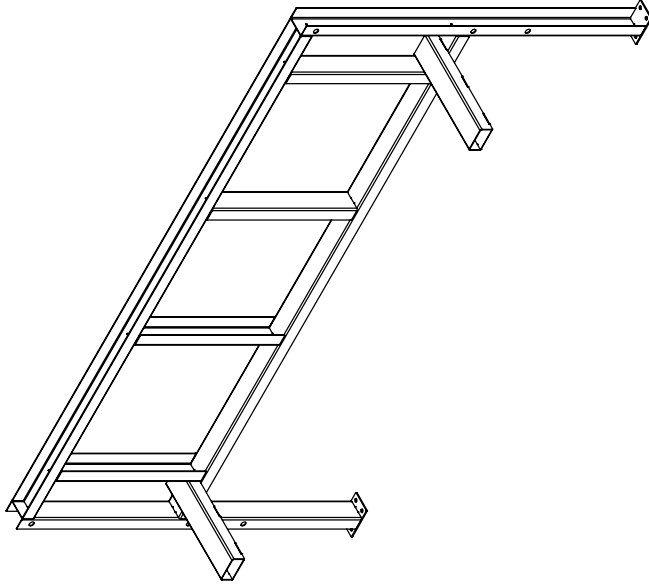

Part Number: W-H4196-0175

Scrub Sink Drawing #: S700048

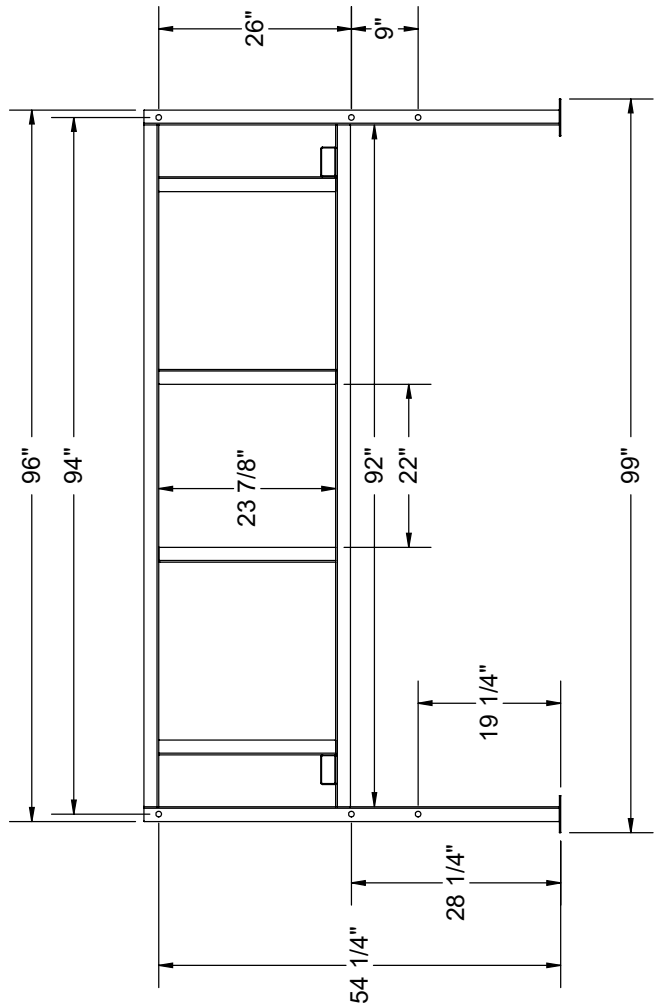
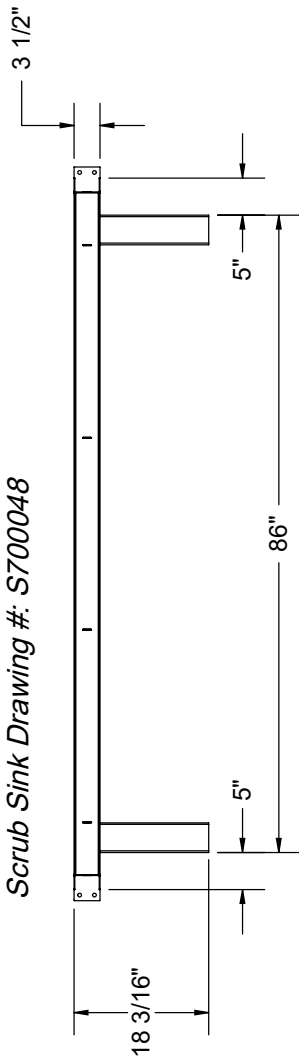

**DRAWING: CWSSS-3 Wall Carrier Detail**

**DRAWING: Electronic Valve Detail**

**FOR USE ON FIXTURES EQUIPPED WITH (IR) ACTUATION AND (T/P) OR (PB) MIXING VALVE(S)**

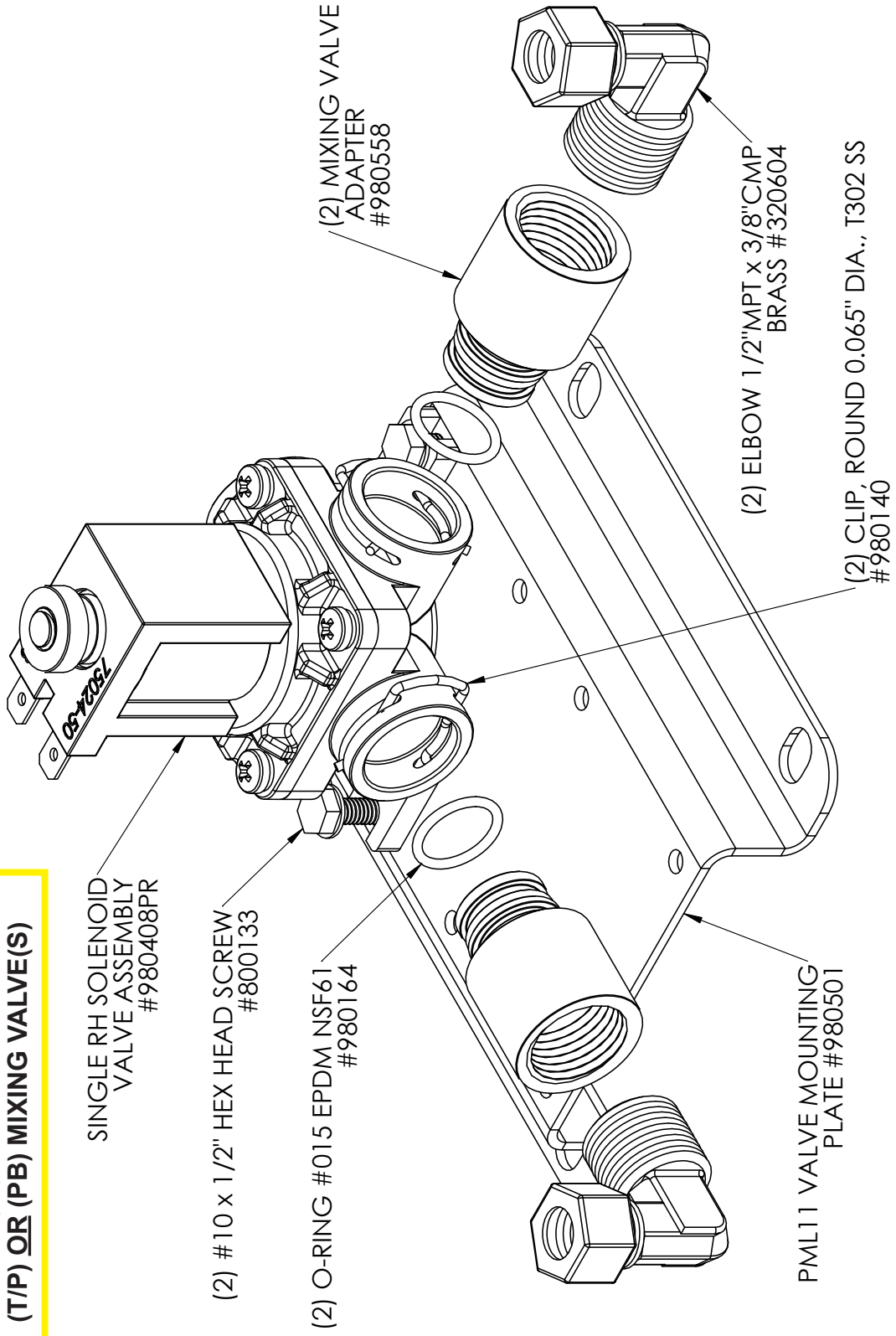

SINGLE RH SOLENOID VALVE ASSEMBLY #980408PR

(2) #10 x 1/2" HEX HEAD SCREW #800133

(2) O-RING #015 EPDM NSF61 #980164

(2) MIXING VALVE ADAPTER #980558

(2) ELBOW 1/2" MPT x 3/8" CMP BRASS #320604

(2) CLIP, ROUND 0.065" DIA., T302 SS #980140

PML11 VALVE MOUNTING PLATE #980501

 <p>Willoughby Industries Inc. Indianapolis, Indiana</p>	TITLE / DESC: SOLENOID FOR IADTV SCRUB SINKS		PART #: 600957
	TOLERANCES EXCEPT AS NOTED 2 PLCS ±0.03 3 PLCS ±0.015 FINISH: 125 SCALE: 1:4		REVISION ORG: MCL 6/2/14 REV: A STANDARD SHEET: 1 OF 1

 WILLOUGHBY	<b>Willoughby Industries Inc.</b> Indianapolis, Indiana		Title or Part Description: <b>VALVE ASSY, WASHFOUNT 1-STATION (EL)</b>		Drawing #: <b>803105-1EW</b>	
	Tolerances Except as Noted	2 Places +/- .03 3 Places +/- .015 Fractions +/- 1/32" Angle +/- 1°	Drawn By: TRB	Scale: 1:4	Date: 11/7/11	Qty: N/A
Material:		Job Name: N/A		Part Number:		Approved By:
						Sheet: 1 Of 1

**FOR USE ON FIXTURES EQUIPPED WITH (IR) ACTUATION AND (TMV) MIXING VALVE(S)**

**NOTE: SUBSTITUTE PARTS #980164, #980558, & #320604 FOR ITEM #6: PART#980600A ON CWSSS MODELS**

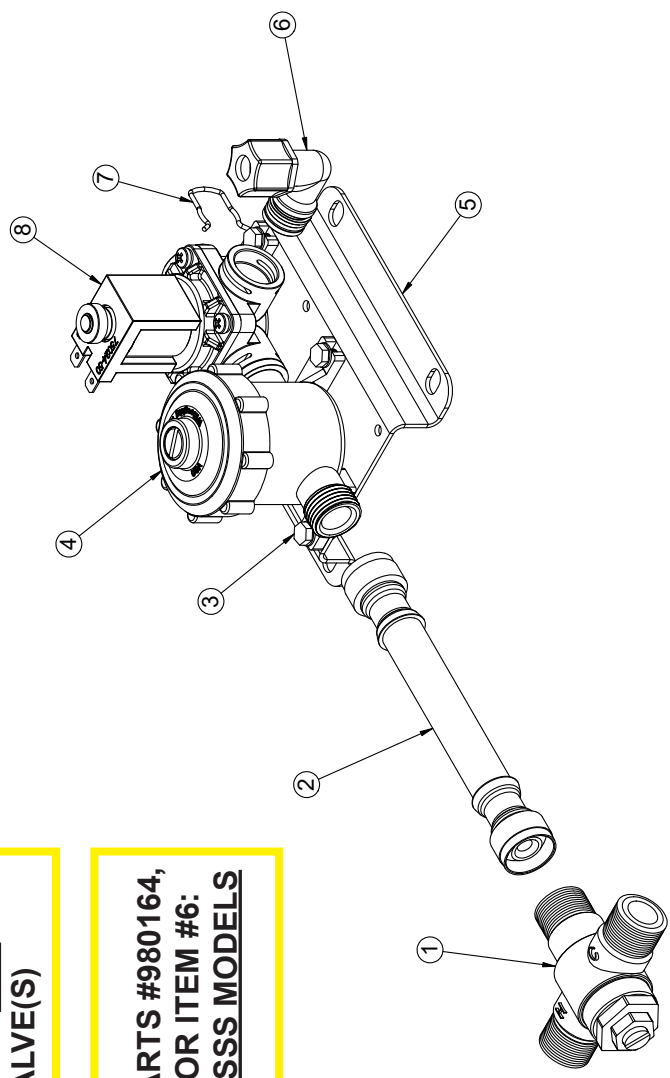

ITEM #	PART #	DESCRIPTION	QTY.
1	700480E	Powers 480E Mixing Valve	1
2	980506	FLEXHOSE, 6"	1
3	800133	#10-16 SELF TAP TYPE B HEX HEAD SCREW	4
4	980183	CHECKSTOP ASSEMBLY	1
5	980501	PM1 VALVE BRACKET	1
6	980600A	VALVE FITTING ASSEMBLY, 3/8" ELBOW	1
7	980140	SPRING CLIP	2
8	980408PR	E1L VALVE ASSEMBLY, RIGHT - PLUGGED PORT	1
9	980520	FLEXHOSE, 20" (NOT SHOWN)	2

NOTE:  
PART#9 - FLEXHOSE, 20" NOT SHOWN

**DRAWING: Electronic Valve Detail**

**DRAWING: Electronic Valve Detail**

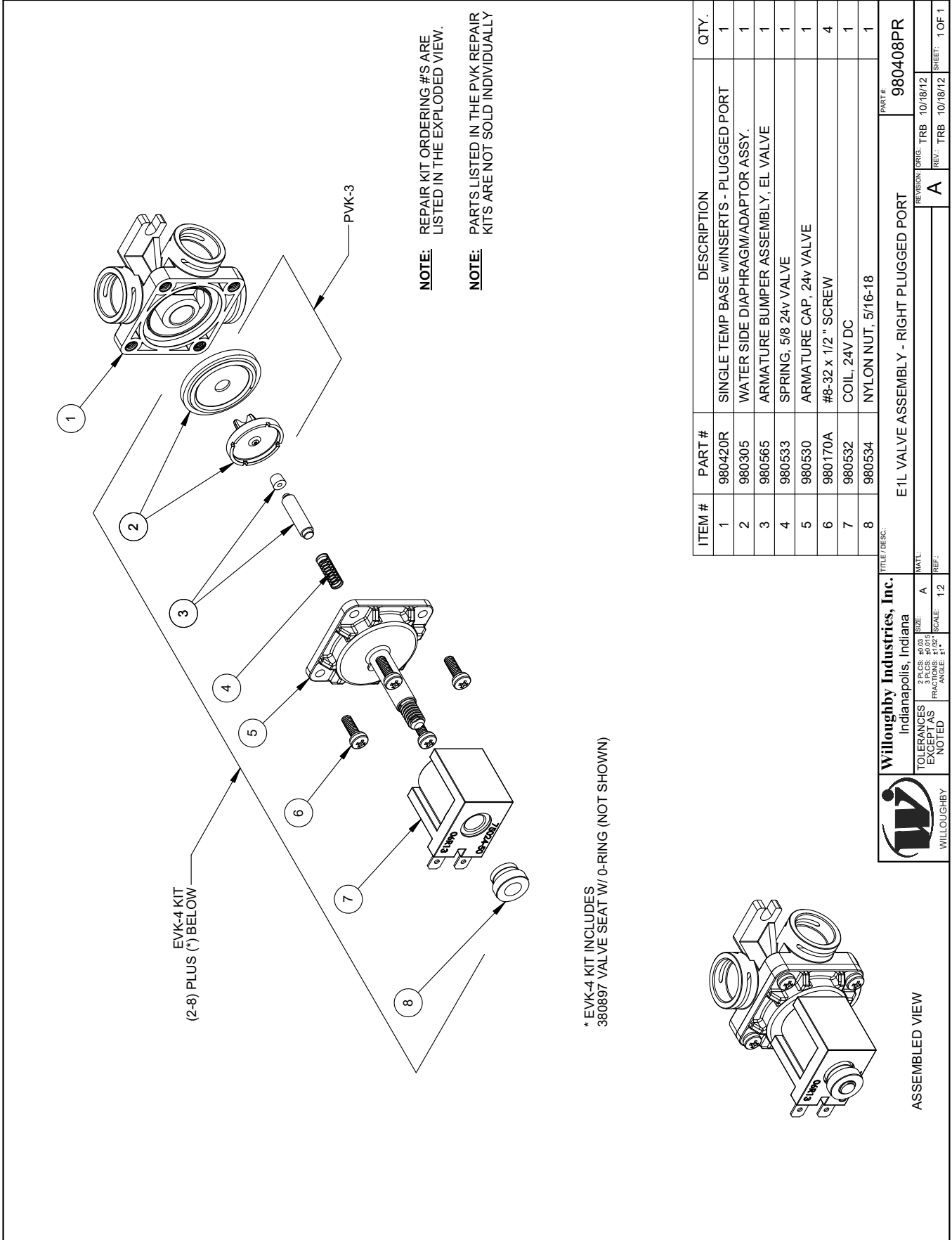

**NOTE:** REPAIR KIT ORDERING #S ARE LISTED IN THE EXPLODED VIEW.

**NOTE:** PARTS LISTED IN THE PVK REPAIR KITS ARE NOT SOLD INDIVIDUALLY

\* EVK-4 KIT INCLUDES 380897 VALVE SEAT W/ O-RING (NOT SHOWN)

ITEM #	PART #	DESCRIPTION	QTY.
1	980420R	SINGLE TEMP BASE W/INSERTS - PLUGGED PORT	1
2	980305	WATER SIDE DIAPHRAGM/ADAPTOR ASSY.	1
3	980565	ARMATURE BUMPER ASSEMBLY, EL VALVE	1
4	980533	SPRING, 5/8 24V VALVE	1
5	980530	ARMATURE CAP, 24V VALVE	1
6	980170A	#8-32 x 1/2" SCREW	4
7	980532	COIL, 24V DC	1
8	980534	NYLON NUT, 5/16-18	1

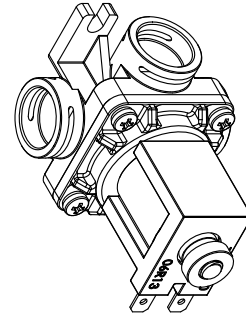

ASSEMBLED VIEW

<b>Willoughby Industries, Inc.</b> Indianapolis, Indiana		TITLE / DESC: E1L VALVE ASSEMBLY - RIGHT PLUGGED PORT PART #: 980408PR	
TOLERANCES EXCEPT AS NOTED	2 PLCS: 2/32" SIZE: A FRACTIONS: 1/32" SCALE: 1:2	REVISION: ORIG. TRB 10/18/12 REV.: TRB 10/18/12	SHEET: 1 OF 1

## **Warranty**

Willoughby Industries, Inc. warrants to commercial and institutional purchasers only that each unit will be free from defects in workmanship and materials under normal use and service upon the following terms and conditions for a period of one (1) year from date of shipment.

This warranty does not cover installation or any other labor charges and does not apply to any components damaged by accident, abuse, improper installation or improper maintenance. This warranty does not cover any installation that did not comply with national, state and local building, plumbing or electrical codes. The warranty is limited to replacing or repairing at manufacturer's option, transportation charges prepaid by the purchaser, any component or part which upon our inspection shall be deemed as defective within the limitations of this warranty. The replacement or repair of defective units as stated in this warranty shall constitute the sole remedy of the purchaser and the sole liability of Willoughby Industries, Inc. Willoughby Industries, Inc. shall not otherwise be liable under any indirect damages caused by defects in the repair or replacement thereof.

This warranty only extends to commercial and industrial purchasers and does not extend to any others, including consumer customers of commercial institutional purchasers. This warranty is in lieu of all other warranties, expressed or implied, including implied warranty of merchantability or fitness for a particular purpose or otherwise.

**(Page intentionally left blank)**

---

## Manufacturers Appendix

### HIGHLAND LABS Model 415

Thigh-Operated Water Control Valve

Rev. 8/2015 \_\_\_\_\_ Pg. 36-38

### HIGHLAND LABS Model 470

Thigh-Operated Soap Dispenser

Rev. 8/2015 \_\_\_\_\_ Pg. 39-41

### VEEDER-ROOT Series C342

(Veeder-Root Model# C342-1474)

Self-Powered LCD Timer (Willoughby option "DTD")

Rev. 8/2015 \_\_\_\_\_ Pg. 42-45

**Model 415**



**Model 415 Repair Kit**

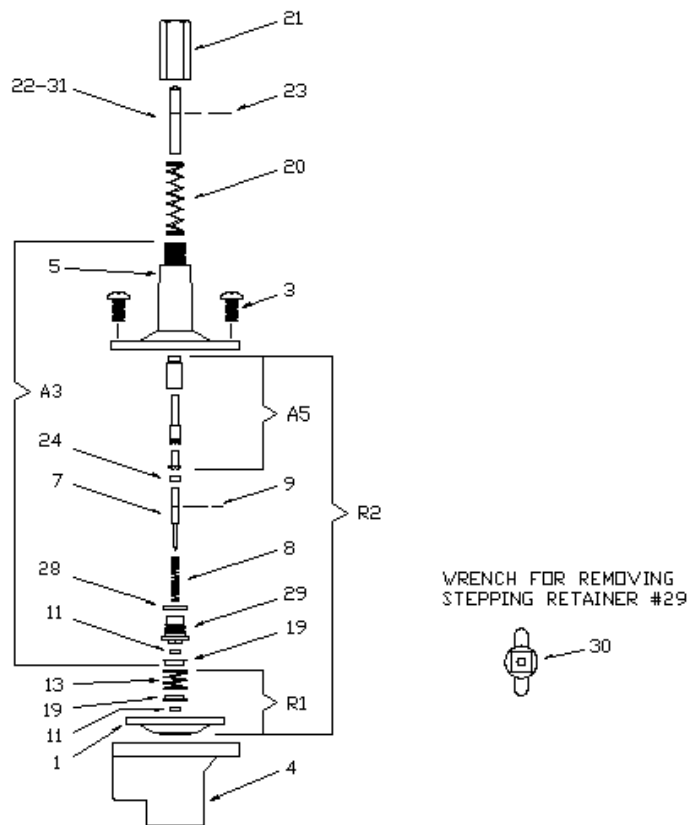

<b>Part #</b>	<b>Part Name:</b>
A1	Model 415 Water Control Valve
A3	Cover Assembly
A5	Stepping Mechanism
R1	Repair Kit (3 pcs) *
R2	Repair Kit (15 pcs)
1	Diaphragm with "O" Ring

- 3 Screw
- 4 Valve Housing
- 5 Cover (bronze casting only)
- 7 Control Rod
- 8 Control Rod Spring
- 9 'E' Ring
- 11 'O' Ring
- 13 Diaphragm Spring
- 19 'O' Ring Retainer
- 20 Spring
- 21 Cap
- 22 Rod (Standard)
- 23 'E' Ring
- 24 Spacer
- 28 'O' Ring
- 29 Stepping Retainer
- 30 Removal & Insertion Tool for Retainer (29)
- 31 Rod (AMSCO SPECS-Nickel Plate +1/8")

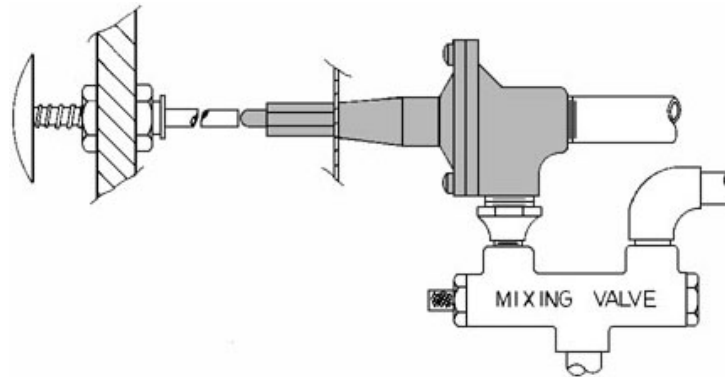

**HIGHLAND LABS, INC.**  
163 Woodland Street  
Holliston, MA 01746  
508-429-2918 Fax 508-429-6283

**APPENDIX: HIGHLAND (MODEL 415)**

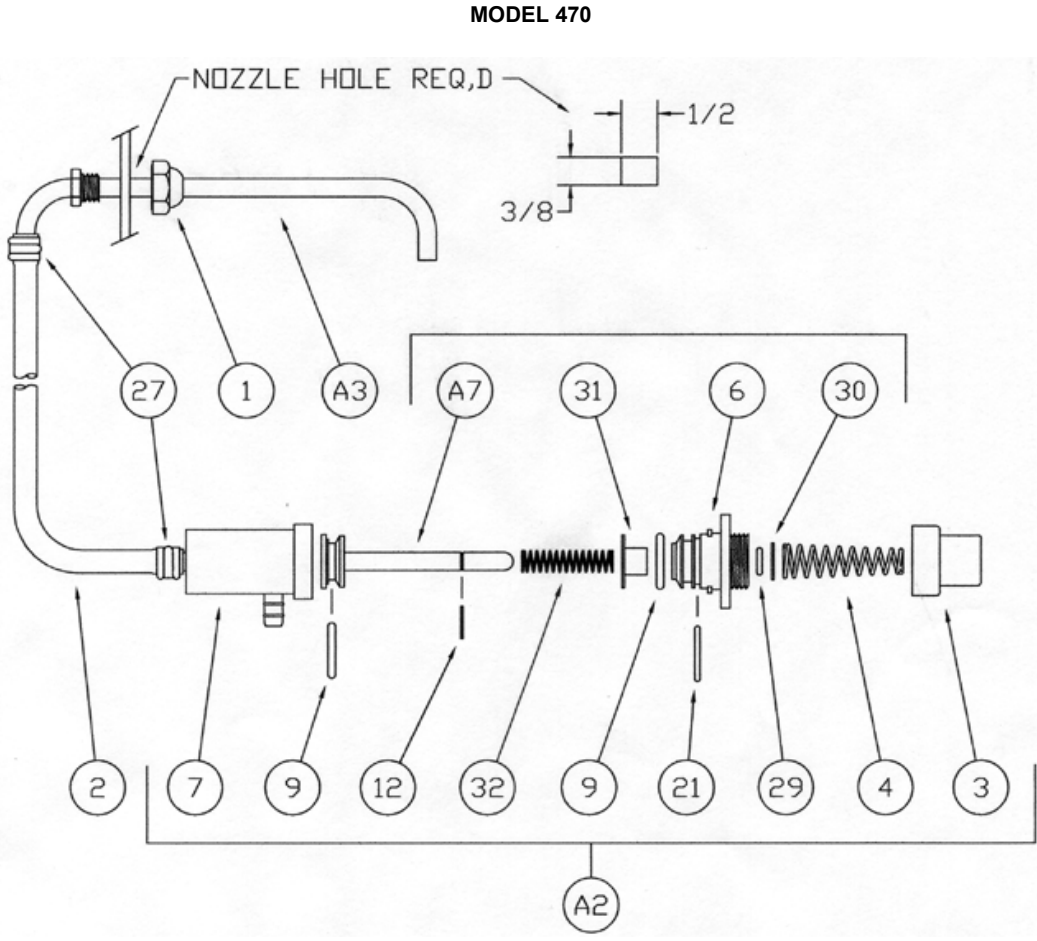

**NOTE:**

1. One half inch travel needed to dispense 3 c.c.
2. To prevent leakage back from nozzle to supply bottle, piston must be allowed to return fully.
3. This unit can be taken apart for servicing.  
Hold cylinder #7 and turn body #6 clockwise approximately ten degrees, then pull apart.

No.	Quan.	Description
A1	1	Model 470 Assembly
A2	1	Pump Assembly
A3	1	Nozzle Assembly
A7	1	Piston Assembly
1	1	Nozzle Nut

**APPENDIX: HIGHLAND (MODEL 470)**

2	1	Tubing 6 FT
3	1	Pump Nut
4	1	Spring
6	1	Pump Body
7	1	Cylinder
9	1	"O" Ring 9/16 x 3/4 x 3/32
12	1	"E" Ring
21	1	"O" Ring 5/8 x 3/4 x 1/16
27	1	Clamp
29	1	"O" Ring 1/4 x 3/8 x 1/16
30	1	"O" Ring Retainer
31	1	Inlet Spider
32	1	Inlet Spring
R1	4	"O" Ring Repair Kit
R1 V	4	"O" Ring Repair Kit (Viton Rubber)

**HIGHLAND LABS, INC.**  
163 Woodland Street  
Holliston, MA 01746  
508-429-2918 Fax 508-429-6283

**APPENDIX: HIGHLAND (MODEL 470)**

**Introduction**

Your Veeder-Root brand Series C342 panel instrument is powered by an internal lithium battery, features an 8 digit LCD display and is housed in a ultra compact 1/32 DIN package. An IEC IP65 rated front panel is suitable for washdown environments.

All models feature signal and remote-reset inputs capable of accepting the high voltage AC or DC impulses. They can be applied in much the same manner as electromechanical devices of similar voltage rating, but have the inherent life and reliability benefits of modern electronic design.

This product has been configured at the factory to perform one of the following functions: Count Totalizer, Time Totalizer (Hours:Minutes:Seconds), or Time Totalizer (Hours, 1/100 resolution).

The following pages of the manual will provide information on proper panel mounting of the device, terminal layout and wiring instructions, as well as an overview of the basic operating functions of the unit. Also included are the key product specifications, warranty procedures, and ordering information should you require additional units.



**Models Covered in this Manual**

**C342-0474 Totalizer:** Accumulates and displays counted pulses. Total can be reset via front panel button (may be disabled) or remote reset terminals.

**C342-1474 Time Totalizer:** Accumulates time in the format Hours:Minutes:Seconds. Can be reset via front panel button (may be disabled) or remote reset terminals.

**C342-2474 Time Totalizer:** Accumulates time in hours with 1/100 resolution. Can be reset via front panel button (may be disabled) or remote reset terminals.

Other matching C342 models are available which offer features such as a 6 digit LED display, quadrature (bidirectional encoder) input capability, factory programmed presets and scale values, and a message display with alpha numeric capability. Ask us for more information regarding the complete C342 family of products.

**Index**

Overview	
Installation	page 2
Terminal Connections	page 3
Setup	
Front Panel Operation	page 3
General	
Specifications	page 4
Ordering Information	page 4
Warranty	page 4

**Features**

- Available models include count and time totalization
- Unique input circuit accepts 12 to 250 V, AC/DC, for signal and reset functions
- Crisp 8 digit LCD display provides easy to read process values
- Compact 1/32 DIN bezel and 60mm behind the panel depth save panel space
- Internal lithium battery provides long life and eliminates the need for external power
- IEC IP65 rated front panel for use in washdown environments

**Technical Manual  
702084-0001**

**Veeder-Root brand  
Series C342  
Self Powered  
LCD Display  
HV Input**

APPENDIX: VEEDER-ROOT (DTD)

# O V E R V I E W

## INSTALLATION

### Dimensions

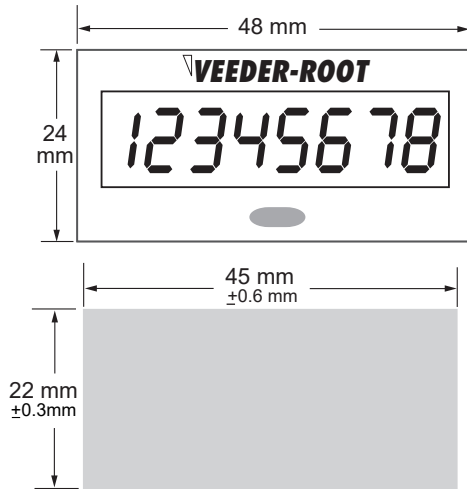

### Energy Conservation Mode

In order to maximize the lifetime of the internal battery the unit is shipped in a low energy use mode. When in this mode, the display will appear as shown in the figure below. Prior to use, the unit must be woke up by pressing the front panel reset key. Please note that the Energy Conservation Mode can not be reactivated.

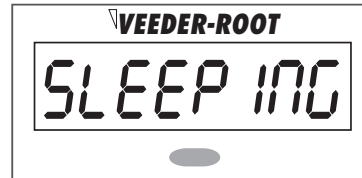

### Panel Mounting

Make a panel cutout per the recommended opening illustrated by the figure above. Place the included gasket over the rear of the unit and place the unit in the panel cutout. Slide the panel mount bracket into place over the unit's rear allowing the bracket tabs to engage the grooves on the case. Continue to push forward until the bracket arm fits snugly against the panel.

### Top View

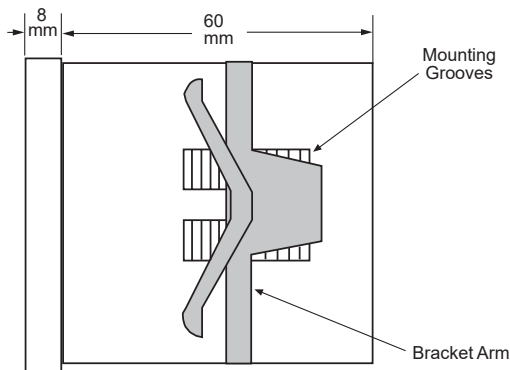

**S E T U P**

**REAR TERMINAL CONNECTIONS**

Top View of Terminals

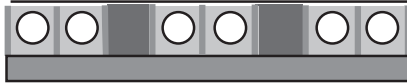

Rear View of Terminals

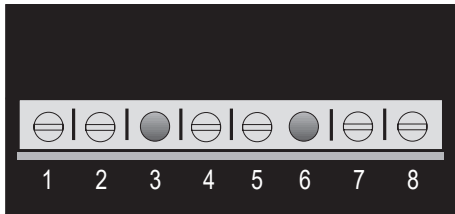

**Wiring**

Insert wire into the appropriate openings as pictured in the drawings on this page. Turn the screws, located on the rear of the terminal block to tighten the clamp and secure the wire. Terminals 3 and 6 are not used.

	<p><b>Remote Reset:</b> the displayed value will be reset. Signal input is ignored when the Reset is active. The main and neutral (for AC) and the positive and negative (for DC) are not polarity dependant.</p>
	<p><b>Signal Input:</b> Voltage signals are accumulated for count. <b>For timer versions,</b> timer runs when signal is present. The main and neutral (for AC) and the positive and negative (for DC) are not polarity dependant.</p>
	<p><b>Reset-lock Input:</b> When active, the Front Panel Reset Function is restricted. Use jumper for full restriction or key-switch for selective restriction. <b>Do not apply voltage.</b></p>

**OPERATION**

**Front Panel Reset**

Used to reset the Process Value Display, unless disabled through the keylock input



**Process Value Display**

Displays the count or time value based upon the model

Dependant on model, your C342 will perform one of the following functions:

**C342-0474 Totalizer:** The instrument will accumulate and display the pulses received on the input terminals (1 & 2). Count capacity is 8 digits: [12345678]. The total can be reset via the remote input terminals (7 & 8) or the front panel. Connecting terminals 4 & 5 will disable the front panel reset key.

**C342-1474 Time Totalizer:** The instrument will accumulate time when the input signal (terminals 1 & 2) is active. The time will be displayed in the format: [9999:59:59] Hours:Minutes:Seconds and can be reset via the remote input terminals (7 & 8) or the front panel. Connecting terminals 4 & 5 will disable the front panel reset key.

**C342-2474 Time Totalizer:** The instrument will accumulate time when the input signal (terminals 1 & 2) is active. The time will be displayed in hours with 1/100 resolution [99999999] and can be reset via the remote input terminals (7 & 8) or the front panel. Connecting terminals 4 & 5 will disable the front panel reset key.

APPENDIX: VEEDER-ROOT (DTD)

**G E N E R A L**

**SPECIFICATIONS**

**Count Input:**

Count Input: 12 - 250 Volts AC/DC  
 Count Speed: 20 Hz max  
 Logic: Low < 3.0 volts, High > 12 Volts  
 Minimum Pulse Width: 25 ms

**Operation:**

Power Source: Internal Lithium Battery  
 Expected Battery Life: 7 Years  
 Display Type: 8 digit LCD  
 Display Height: 7 mm  
 Operating Temperature: -10°C to 50°C  
 Storage Temperature: -20°C to 60°C  
 Approvals: CE

**Reset Input:**

Type: 12 - 250 Volts AC/DC  
 Logic: Low < 3.0 volts, High > 12 Volts  
 Minimum Pulse Width: 25 ms

**Physical:**

Dimensions: 24mm x 48mm, 60 mm deep  
 Mounting: Panel Mount (mounting bracket supplied)  
 22mm (± 0.3mm) x 45mm (± 0.6mm) panel cutout  
 Maximum Panel Thickness: 26mm  
 Connections: 6 screw terminals  
 Weight: Approximately 2.25 ounces  
 Front Panel Rating: IEC IP65

**ORDERING INFORMATION**

<u>Part #</u>	<u>Description</u>
C342-0474	Count Totalizer
C342-1474	Timer (H:M:S)
C342-2474	Timer (Hundredths of Hours)

**WARRANTY**

Standard products manufactured by the Company are warranted to be free from defects in workmanship and material for a period of one year from the date of shipment, and products which are defective in workmanship or material will be repaired or replaced, at the option of the Company, at no charge to the Buyer. Final determination as to whether a product is actually defective rests with the Company. The obligation of the Company hereunder shall be limited solely to repair and replacement of products that fall within the foregoing limitations, and shall be conditioned upon receipt by the Company of written notice of any alleged defects or deficiency promptly after discovery within the warranty period, and in the case of components or units purchased by the Company, the obligation of the Company shall not exceed the settlement that the Company is able to obtain from the supplier thereof. No products shall be returned to the Company without its

prior consent. Products which the Company consents to have returned shall be shipped F.O.B. the Company's factory. The Company cannot assume responsibility or accept invoices for unauthorized repairs to its components, even though defective. The life of the products of the Company depends, to a large extent, upon the type of usage thereof, and THE COMPANY MAKES NO WARRANTY AS TO FITNESS OF ITS PRODUCTS FOR SPECIFIC APPLICATIONS BY THE BUYER NOR AS TO PERIOD OF SERVICE UNLESS THE COMPANY SPECIFICALLY AGREES OTHERWISE IN WRITING AFTER THE PROPOSED USAGE HAS BEEN MADE KNOWN TO IT.

THE FOREGOING WARRANTY IS EXCLUSIVE AND IN LIEU OF ALL OTHER WARRANTIES EXPRESSED OR IMPLIED, INCLUDING, BUT NOT LIMITED TO ANY WARRANTY OF MERCHANTABILITY OR OF FITNESS FOR A PARTICULAR PURPOSE.



1675 N. Delany Road  
 Gurnee, IL 60031-1282  
 Phone: 847.662.2666  
 Fax: 847.662.6633

Printed in U.S.A.  
 #702084-0001  
 February 20, 1997  
 Revision none