

Installation & Operation Manual

LRBCL-2030 Series

Ligature-resistant Solid Surface Behavioral Healthcare Corner Lavatory

Table of Contents

Pre-Installation Information	3
Physical Dimensions	4
Mounting Dimensions.....	6
Check Contents.....	7
Required Installation Supplies.....	8
Parts List.....	9
Exploded-view Drawing	10
Hardware Identification	11
Installation Instructions.....	
Step 1: Pedestal Mounting.....	12
Step 2: Drain Assembly #380280.....	13
Step 3a: Pneumatic Push Button Faucet Mounting	14
Step 3b: Piezo Electronic Push Button Faucet Mounting	15
Step 3c: Plug-in / Battery Operated Infrared Faucet Mounting	16
Step 4: Basin and Pedestal Assembly	17
Step 5: Final Assembly	18
In-wall Mounting Carrier	19
JACO Fitting Instructions	21
Adjustable Mixing Valve Installation	22
Infrared Lavatory Sensor Installation	
Plug-in Infrared Sensor	23
Battery Operated Infrared Sensor	24
Faucet Part Numbers	25
Troubleshooting.....	
Infrared Sensors	27
Electronic Valves.....	28
Pneumatic Valves	29
Care and Maintenance.....	30
Drawings	
Valve Details	31
Push Button Details	35
Warranty	37

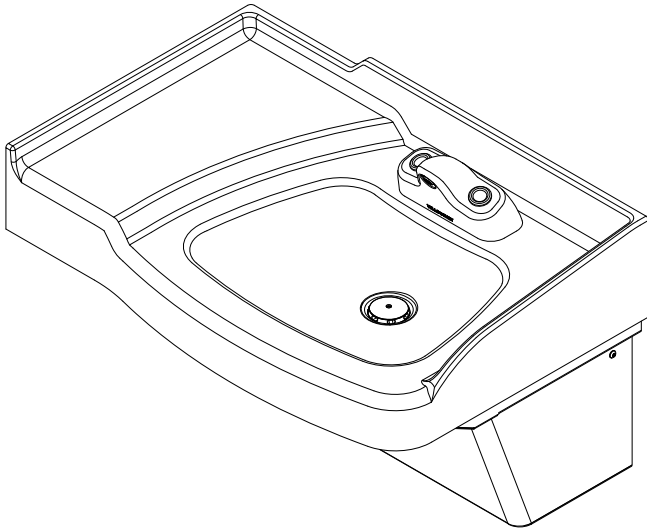

LRBCL-2030



PATENTED: D1,010,077



Willoughby Industries, Inc.

5105 West 78th Street
Indianapolis, IN 46268

Toll Free: (800) 428-4065

Local: (317) 875-0830

Fax: (317) 875-0837

www.willoughby-ind.com

WILLOUGHBY

Rev. 6/2025

MADE IN THE U.S.A.



(Page left intentionally blank)

Pre-Installation Information

Installation notice!

Check Rough-In location **PRIOR** to installation

Flush lines thoroughly **PRIOR** to hook-up

When installing the **Willoughby Industries' LRBCL-2030 Series** lavatory deck systems:

Before step 1 of the installation instructions, ensure that rough-ins are in the correct location.

The valve assembly, including the faucet, **MUST NOT BE** connected until *after* all lines have been flushed to remove the small particles of debris that are inherent with new construction projects and all chemicals that are used in flushing are purged from the system.

Chemicals used in flushing plumbing systems can attack the internal components of the valve and faucet and severely damage them, so any flushing of the system must be followed by a full flushing with pure water to clear any harsh chemicals remaining in the system. Debris in the system if allowed to enter the valve assembly and faucet can cause poor performance or failure.

Again **DO NOT** attempt to connect the valve assembly and faucet until *after* all flushing is complete and pure water is the only media that will be passing through the system. Damage to the valve assembly or faucet caused by harsh chemicals or debris will not be covered by the manufacturer's warranty.

Installation notice!

Check Rough-In location **PRIOR** to installation

Flush lines thoroughly **PRIOR** to hook-up

Physical Dimensions- LRBCL-2030-R



PATENTED: D1,010,077

AQUASURF SOLID SURFACE COLORS:

- [] (BN) BONE
- [] (GW) GLACIER WHITE
- [] (GG) GREY GRANITE
- [] (SS) SANDSTONE
- [] (WG) WHITE GRANITE
- [] (BG) BLACK GRANITE

FAUCET OPTIONS:

- [] (LRFC-PBH) LIG.-RESISTANT PNEUMATIC PUSH BUTTON
- [] (LRFC-PZPB) LIG.-RESISTANT PIEZO ELECTRONIC PUSH BUTTON*
- [] (LRFC-IR) LIG.-RESISTANT PLUG-IN INFRARED SENSOR*
- [] (LRFC-BO) LIG.-RESISTANT BATTERY OPERATED INFRARED SENSOR
- [] (NV) LESS FAUCET (SPECIFY HOLE SIZE AND LOCATION)

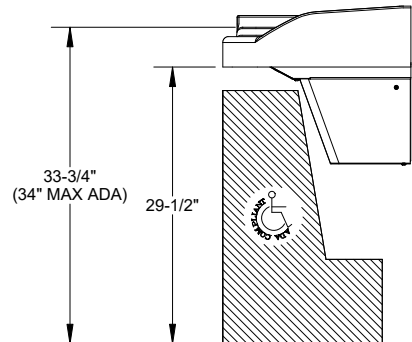
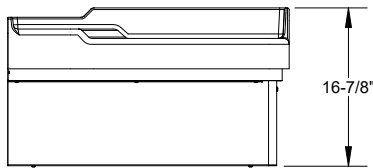
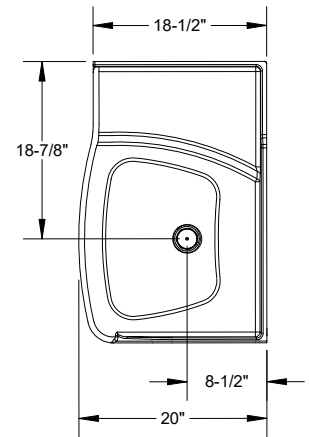
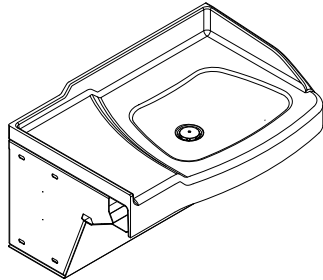

Physical Dimensions- LRBCL-2030-L

 **IN COMPLIANCE WITH A.D.A. 2010**

PATENTED: D1,010,077

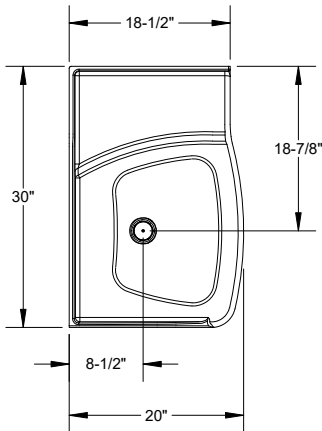

AQUASURF SOLID SURFACE COLORS:

- [] (BN) BONE
- [] (GW) GLACIER WHITE
- [] (GG) GREY GRANITE
- [] (SS) SANDSTONE
- [] (WG) WHITE GRANITE
- [] (BG) BLACK GRANITE

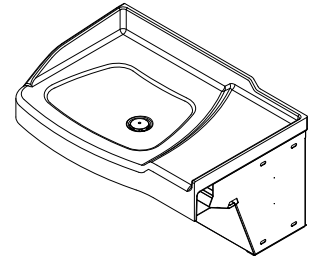

FAUCET OPTIONS:

- [] (LRFC-PBH) LIG.-RESISTANT PNEUMATIC PUSH BUTTON
- [] (LRFC-PZPB) LIG.-RESISTANT PIEZO ELECTRONIC PUSH BUTTON*
- [] (LRFC-IR) LIG.-RESISTANT PLUG-IN INFRARED SENSOR*
- [] (LRFC-BO) LIG.-RESISTANT BATTERY OPERATED INFRARED SENSOR
- [] (NV) LESS FAUCET (SPECIFY HOLE SIZE AND LOCATION)

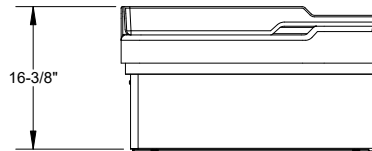
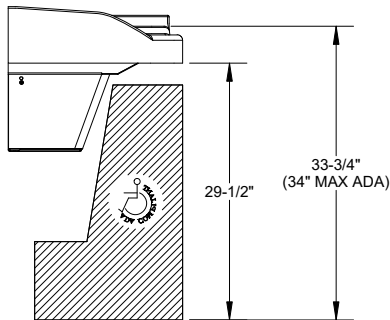

Mounting Dimensions- LRBCL-2030

**** NOTE: ADEQUATE WALL BACKING AND MOUNTING HARDWARE BY OTHERS**

RIGHT HAND BOWL SHOWN
 LEFT HAND BOWL SYMMETRICALLY OPPOSITE

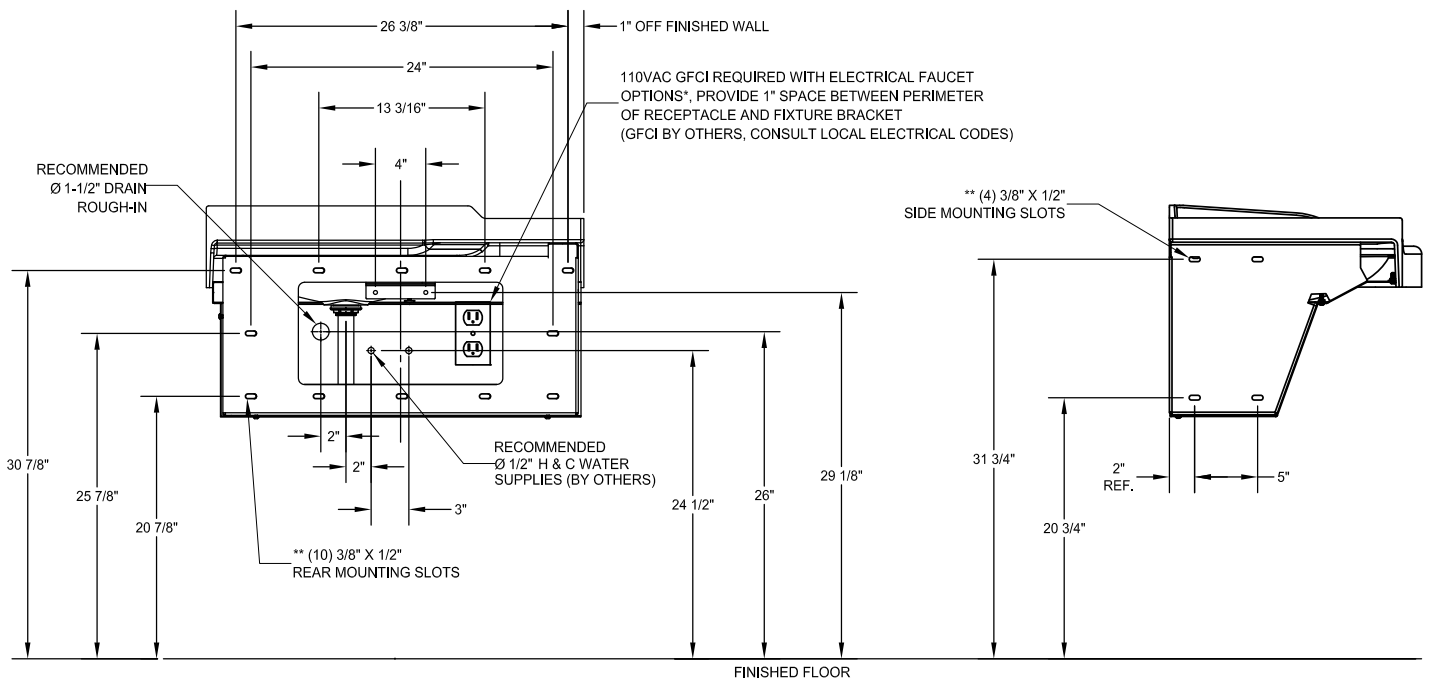

Check Contents

- Separate all parts from packaging and make sure all parts are accounted for before discarding any packaging material. If any parts are missing, do not attempt to install LRBCL-2030 Behavioral Health Lavatory until you obtain the missing parts.

NOTE: Before beginning installation, all supply, drain and waste piping for the LRBCL-2030 must be completed according to specified rough-ins. If you have not received rough-in details, please contact Willoughby Industries, Inc. (800) 428-4065

- IMPORTANT: These installation instructions cover all of the Willoughby Industries Inc. LRBCL-2030 Behavioral Health Lavatory Series. Simply omit the steps which do not apply to the model you are installing.**
- IMPORTANT: Flush all the water supply lines before making connections.**

Required Installation Supplies (By others)

- Proper mounting hardware
- Hardware for waste outlet connections
- Gasket for waste outlet connection
- Shims (for installation if necessary)
- Supply piping
- Non-pick caulk
- Silicone caulk

WARNING: Willoughby Industries does not assume any responsibility for personal injury or damage to equipment due to an improperly installed LRBCL-2030 Behavioral Health Lavatory.

Parts List

ITEM	DESCRIPTION	PART NUMBER
1	PNEUMATIC PUSH BUTTON FAUCET ASSEMBLY	LRFC-PBK
	PIEZO ELECTRONIC PUSH BUTTON FAUCET ASSEMBLY	LRFC-PZK
	PNEU. PUSH BUTTON FAUCET ASSEMBLY	LRFC-IR
	PNEU. PUSH BUTTON FAUCET ASSEMBLY	LRFC-BO
2	LAVATORY BASIN - RIGHT	801603R-XX-INV*
	LAVATORY BASIN - LEFT	801603L-XX-INV*
3	DRAIN ASSEMBLY, LRBCL-2030	380280
4	PEDESTAL ASSEMBLY RIGHT, LRBCL-2030	S301898
	PEDESTAL ASSEMBLY LEFT, LRBCL-2030	S301891
5	1/4-20 x 3/4" SECURITY SCREW	4502SSN
6	SHROUD RIGHT	S301902
	SHROUD LEFT	S301668
7	1/4-20 x 1/2" SECURITY SCREW	4500NSS
8	1/4-20 x 1" FLAT WASHER	600650
9	FRONT BRACE	S301896

*XX REPRESENTS THE LAVATORY COLOR

WHITE GRANITE=WG
 SAND STONE=SS
 GRAY GRANITE=GG
 BLACK GRANITE=BG
 GLACIER WHITE=GW
 BONE=B

Exploded-view Drawing

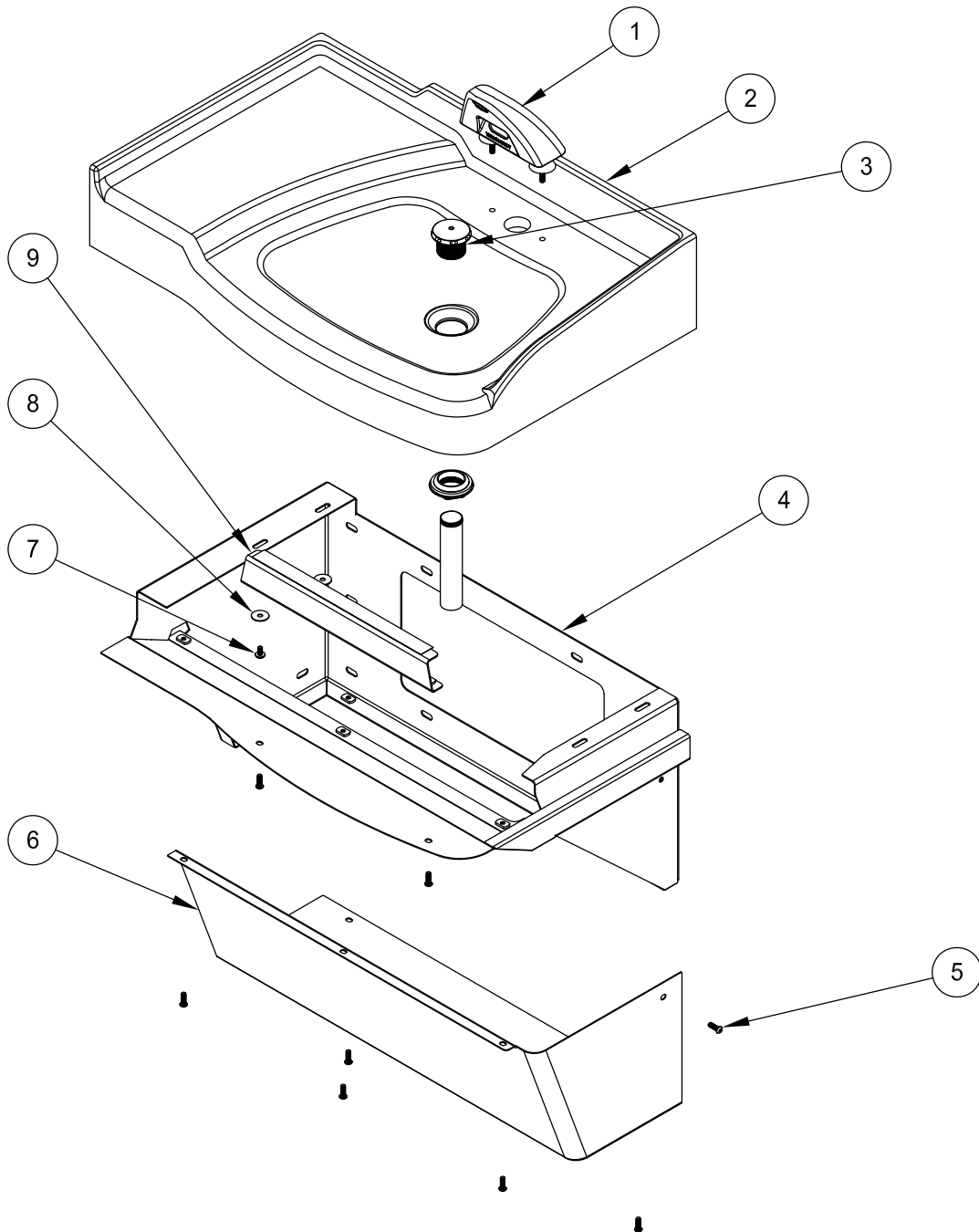

Hardware Identification

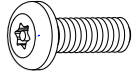

1/4-20 x 3/4"
SECURITY SCREW
4502SSN

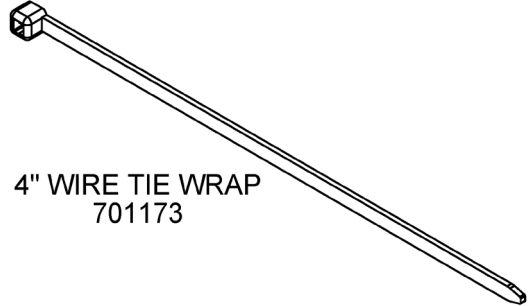

4" WIRE TIE WRAP
701173

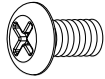

1/4-20 x 1/2"
SECURITY SCREW
4500NSS

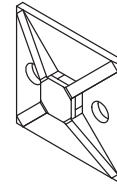

4 WAY WIRE TIE BASE
701206

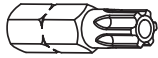

T-27
PINNED TORX BIT

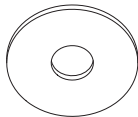

1/4-20 x 1"
FLAT WASHER
600650

Installation Instructions

Step 1: Pedestal Mounting

Parts supplied:

- Pedestal
- Mounting Bracket

Note: Hardware for wall anchoring by others

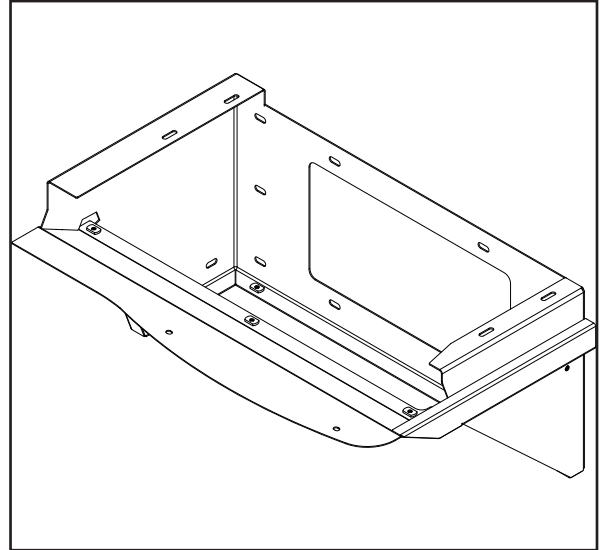

- 1.) Using the mounting dimensions measure and mark the holes for the wall anchors on both the back and side wall.

Note: Pedestal must be level for fixture to drain properly.

- 2.) Secure pedestal to the wall using **all** through slots for secure mounting (adequate wall anchoring hardware and support by others).

Installation Instructions (cont.)

Step 2: Drain Assembly #380280

Parts/Materials supplied:

- Solid Surface basin
- Drain assembly

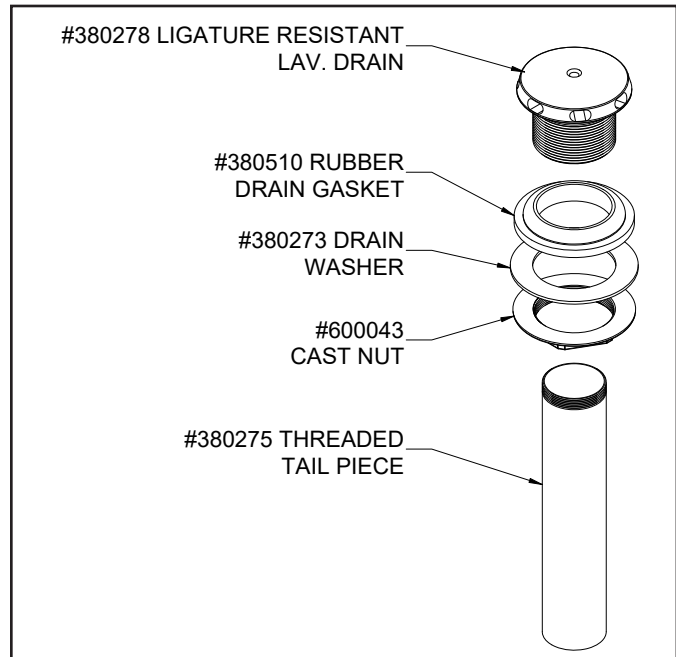

- 1.) Insert drain spud into wash basin using silicone caulk (supplied by others).
- 2.) From beneath basin, thread the washers & locknut onto the drain spud and secure locknut against wash basin.
- 2.) The wash basin is ready for plumbing and/or electrical installation*.

If you have Pnumatic push button faucet, go to Step 3a.

If you have Piezo electronic push button faucet, go to Step 3b.

If you have Plug-in / Battery Operated infrared sensor faucet, go to Step 3c.

Installation Instructions (cont.)

Step 3a: Pneumatic Push Button Faucet Mounting

- 1.) Unscrew the (2) 1/4-20 nuts on the all thread rod and take off the lock washers and centering washers.
- 2.) Unscrew the (4) 8-32 screws from the mounting plate and remove the plate from the bottom of the faucet.
- 3.) Connect the included 1/8" Red and Blue tubing to the barbs of the push buttons.
- 4.) Replace the mounting plate onto the bottom of the faucet, feeding the (2) tubes from the push button through the center hole. Use the (4) 8-32 screws to secure the plate to the mounting tabs of the faucet.
- 5.) Make sure the deck gasket for the faucet is on the faucet and both all-thread rods, and pneumatic tubing for the push buttons are through the gasket.

Note: Faucet can be mounted without the gasket, but the bottom edge will need to be sealed with caulking (non-pick is recommended).

- 6.) From the underside of the basin, align the (2) 1/4-20 all-thread rods with the mounting holes, making sure the pneumatic tubing for both push buttons are through the center hole of the fixture.
- 7.) Install the centering washers, lock washers and nuts onto the all-thread rods (all included). Tighten the nuts until the faucet is secure.

Caution: Do not leave bowl on the pedestal unsupported, as it may fall and cause damage or personal injury.

Installation Instructions (cont.)

Step 3b: Piezo Electronic Push Button Faucet Mounting

- 1.) Unscrew the (2) 1/4-20 nuts on the all thread rod and take off the lock washers and centering washers.
- 2.) Unscrew the (4) 8-32 screws from the mounting plate and remove the plate from the bottom of the faucet.
- 3.) Replace the mounting plate onto the bottom of the faucet, feeding the (2) wires from the push buttons through the center hole. Use the (4) 8-32 screws to secure the plate to the mounting tabs of the faucet.
- 4.) Make sure the deck gasket for the faucet is on the faucet and both all-thread rods, and wires for the push buttons are through the gasket.

Note: Faucet can be mounted without the gasket, but the bottom edge will need to be sealed with caulking (non-pick is recommended).

- 5.) From the underside of the fixture, align the (2) 1/4-20 all-thread rods with the mounting holes, making sure the wiring for both push buttons are through the center hole of the fixture.
- 6.) Install the centering washers, lock washers and nuts onto the all-thread rods (all included). Tighten the nuts until the faucet is secure.
- 7.) Connect each push button to the controller there controller.

Caution: Do not leave bowl on the pedestal unsupported, as it may fall and cause damage or personal injury.

Installation Instructions (cont.)

Step 3c: Plug-in & Battery Operated Infrared Faucet Mounting

- 1.) Unscrew the (2) 1/4-20 nuts on the all thread rod and take off the lock washers and centering washers.
- 2.) Make sure the deck gasket for the faucet is on the faucet and both all-thread rods, PTC fitting, and wires for the IR valve are through the gasket.

Note: Faucet can be mounted with or without the gasket and the bottom edge sealed with non-pick caulking.

- 3.) From the underside of the fixture, align the (2) 1/4-20 all-thread rods with the mounting holes, making sure the PTC fitting and IR sensor wires are going through the central hole.
- 4.) Place the centering washer, lock washer and thread the nut onto the all-thread rods (all included). Tighten the nuts down.

Caution: Do not leave bowl on the pedestal unsupported, as it may fall and cause damage or personal injury.

Installation Instructions (cont.)

Step 4: Basin and Pedestal Assembly

Caution: Do not leave bowl on the pedestal unsupported, as it may fall and cause damage or personal injury.

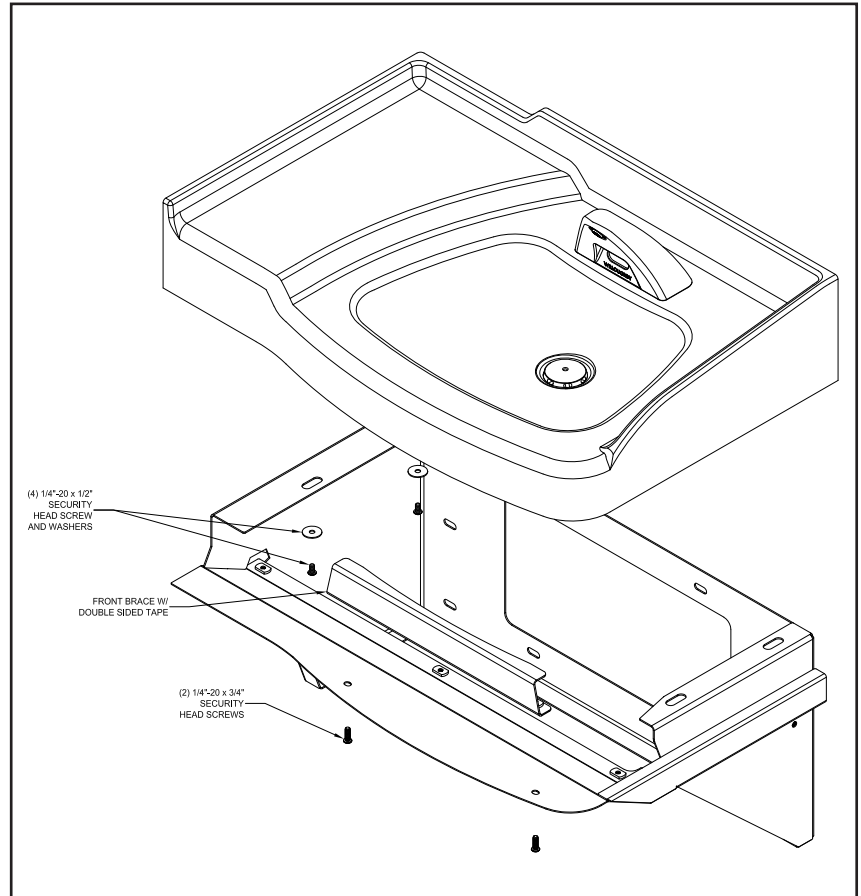

- 1.) Before placing the basin onto the pedestal secure the front brace into place with (2) 1/4-20 x 3/4" security screws and peel the protective strip off the double sided tape.
- 2.) Line up the brass threaded inserts on the bottom of the basin with the 4 holes on the top of the pedestal, secure with (4) 1/4-20 x 1/2" security screws.

Installation Instructions (cont.)

Step 5: Final Assembly

- 1.) Make all final plumbing connections to the drain and valve inlets. The lavatory is supplied with flex hoses (flex hoses have shut-off valves attached that should be connected to the supply inlets).
- 2.) Once all of the connections in the actuator housings are complete, locate the transformer if need.

NOTE: PLUG-IN TRANSFORMER (IF NEEDED) MUST BE USED WITH A GROUND FAULT INTERRUPT (GFCI) RECEPTACLE TO HELP PREVENT POSSIBLE ELECTRICAL SHOCK.

Note: For infrared systems see the start-up procedures and troubleshooting guide in the back of this manual.

- 4.) Test the system for leaks (both supply and waste).
- 5.) If TMV is being used set desired temperature with the adjustable mixing valve (see instruction near the back of this manual).
- 6.) Using non-pick caulk run a bead down across the back and wall side of the basin and along the front under side of the basin and pedestal as shown.
- 7.) Secure the shroud in place with (6) 3/4" security screws.

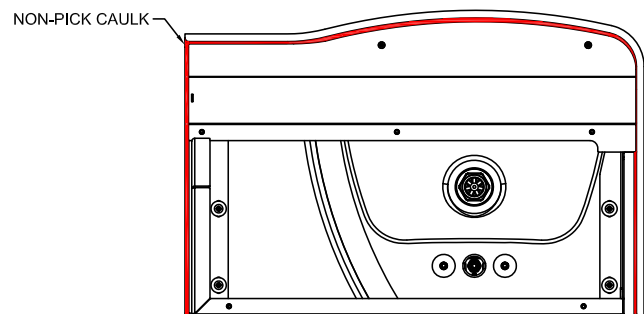
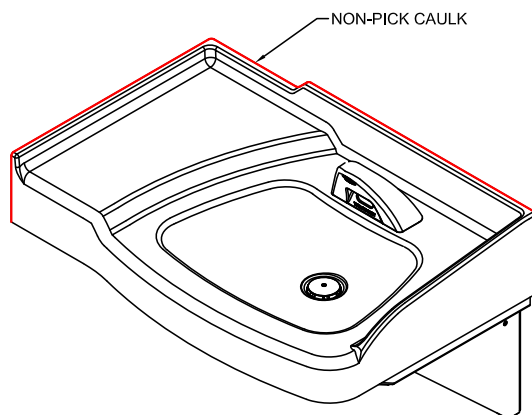

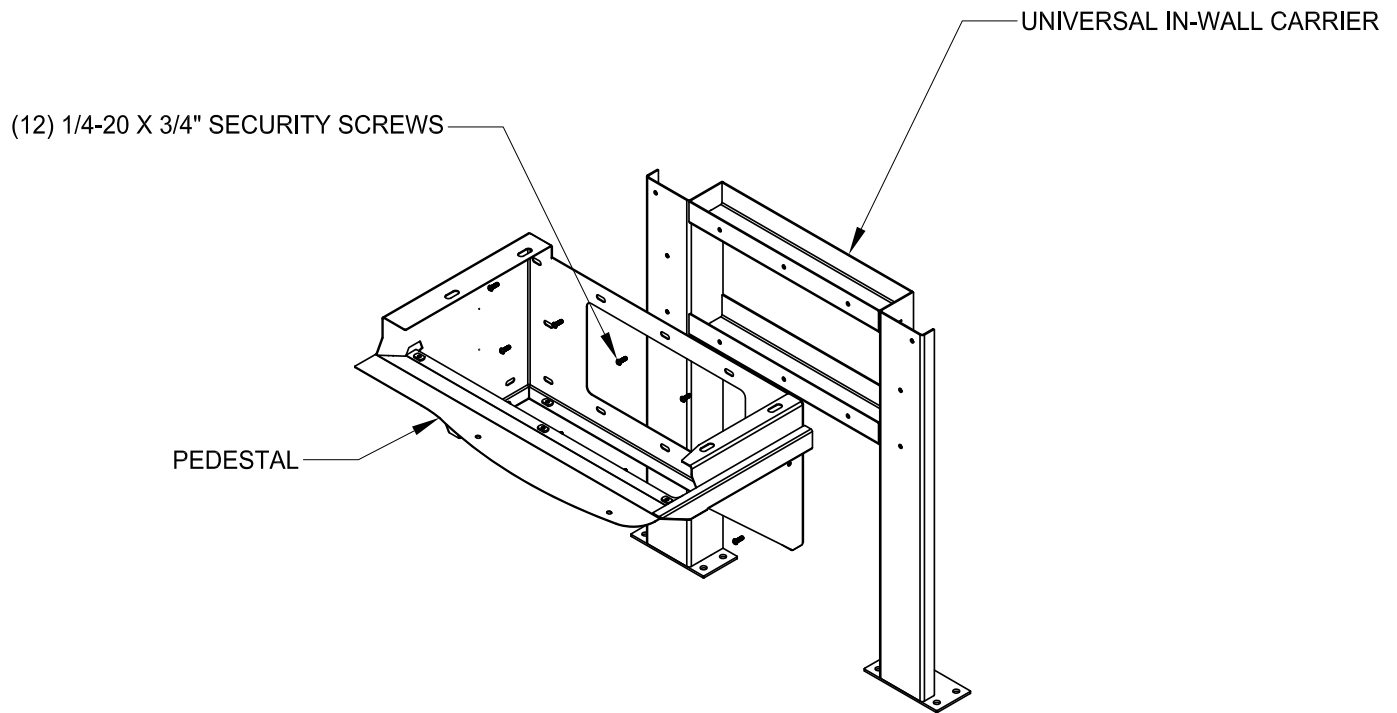

Optional Universal In-wall Mounting Carrier Installation

- 1.) Secure the in-wall mounting carrier to the floor with anchors (provided by others).
- 2.) Using the provided 3/4" security screws secure the pedestal to the mounting carrier.

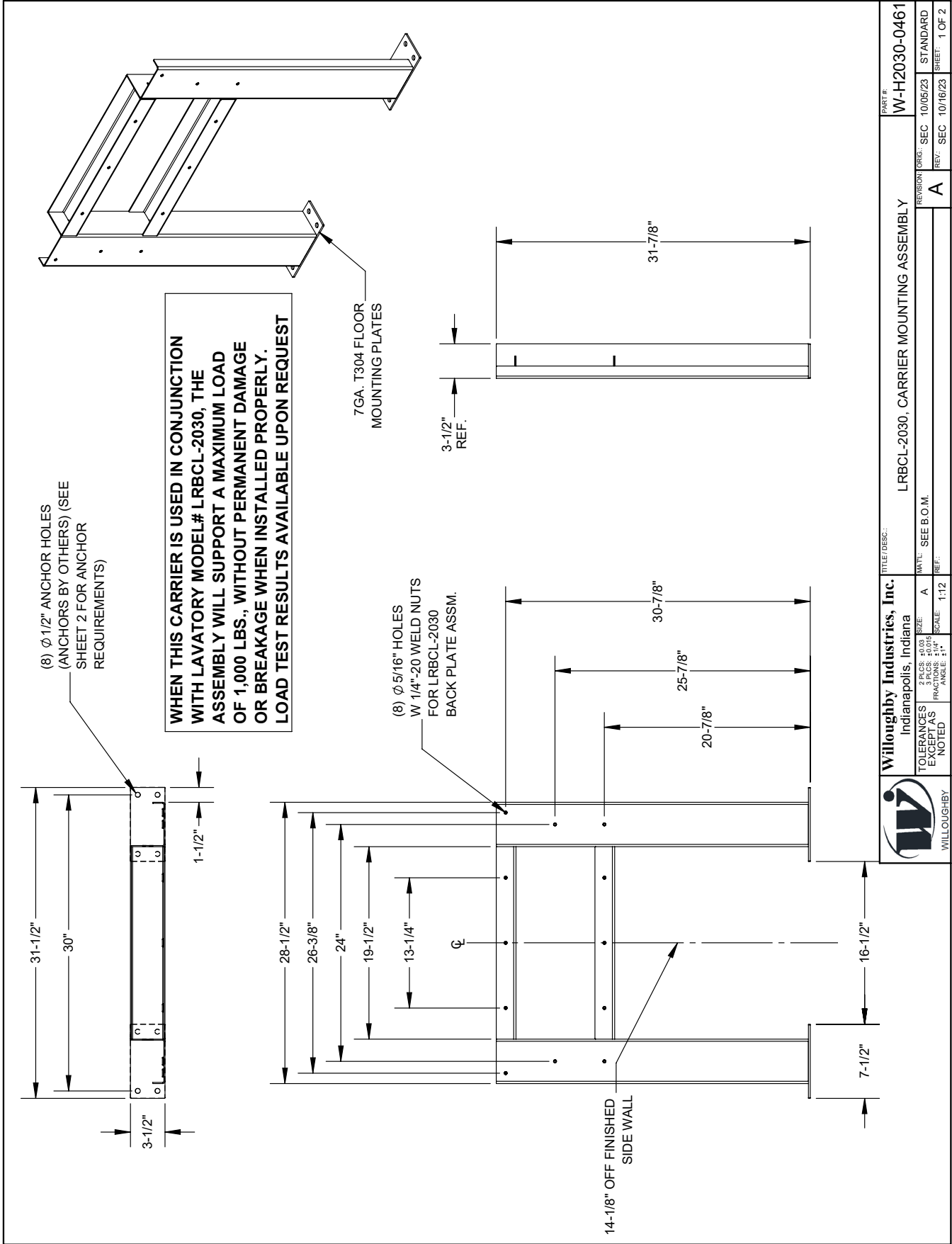

DRAWING: In-wall Mounting Carrier



		Willoughby Industries, Inc. Indianapolis, Indiana 3 PAGES 40.000 FRACTIONS: 1/4" SCALE: 1:12 TOLERANCES: AS NOTED		TITLE / DESC.: LRBCL-2030, CARRIER MOUNTING ASSEMBLY	PART #: WL-H2030-0461
REVISIONS ORG. SEC. 10/05/23 REV. SEC. 10/16/23	A	MATL. SEE B.O.M. REF.	SCALE: 1:12	SHEET: 1 OF 2	STANDARD

JACO Fitting Instruction



Note: It is not necessary to disassemble this fitting for application. Merely insert tubing to stop and tighten seal.

1. Cut tubing end squarely and remove the internal burrs.
2. Insert the tubing through the back of the nut all the way through the nut assembly to the tube stop in the fitting body (see illustration). If the tubing does not enter the nut easily, loosen the nut one turn and reinsert the tubing all the way to the tube stop in the fitting body.
3. Turn the nut hand tight.
4. Wrench tighten the nut $1\frac{1}{2}$ - 2 turns.
5. All nuts must be retightened when the system reaches projected operating temperature.

Note: To ensure proper assembly, tubing MUST be fully inserted into the fitting body all the way to the tube stop.

Note: Squeaking sound when tightening nut is normal. For pipe threaded connections, Teflon tape must be used.

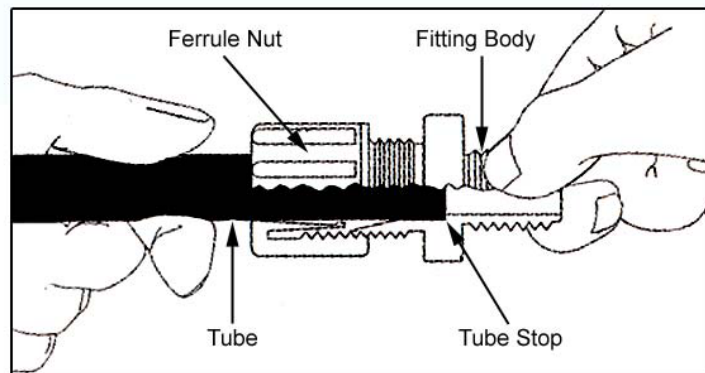
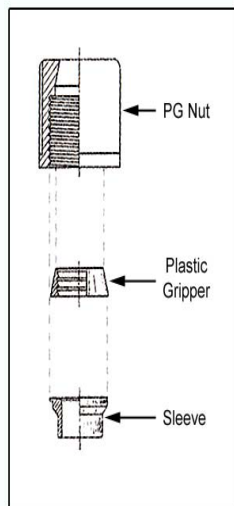

Adjustable Mixing Valve Installation

POWERS™

IS-P-e480

**HydroGuard® T/P Series e480
Lavatory Combination Valve**

Installation Instructions

To Install ■

NOTE: Installation should be in accordance with accepted plumbing practices. Flush all piping thoroughly before installation.

1. Locate a suitable place for the tempering valve. Valve should be accessible for service and adjustment and as close to the point-of-use as possible.
2. Connect hot and cold water to the supply valve using 1/2" NPT or 3/8" compression connections.
3. Connect outlet of tempering valve to fixture(s) using 1/2" NPT or 3/8" compression connections.
4. Turn on hot and cold water supplies. If any leaks are observed, tighten connections as necessary to stop leaks before proceeding.
5. Turn on fixture and allow water to flow for 2 minutes. Measure water temperature at outlet. If water is not at desired temperature, adjust as necessary.

Specifications ■

e480-00	1/2" NPT (Rough Bronze)
e480-01	1/2" NPT (Rough Chrome)
e480-10	3/8" Compression (Rough Bronze)
e480-11	3/8" Compression (Rough Chrome)
Capacity:	4.0 gpm (15.0 l/m)
Approach Temperature:	5°F (2.8°C) above set pt.
Max. Operating Pressure:	125psi (862 kpa)
Max. Static Pressure:	125psi (862 kpa)
Max. Hot Water Temperature:	180°F (82°C)
Temp. Adjustment Range:	
..... ASSE Type T/P:	95 – 110°F (43-48°C)
..... ASSE Type T:	80 – 120°F (27-49°C)
Minimum Flow:	0.5 gpm (2.2 l/m)
Checks:	Integral
Construction:	Cast Brass Body
Certified:	CSA B125
Listing	ASSE 1016-1996 (Type T/P)
.....	ASSE 1070

CALIFORNIA PROPOSITION 65 WARNING

WARNING: This product contains chemicals known to the State of California to cause cancer and birth defects or other reproductive harm. (California law requires this warning to be given to customers in the State of California.)
For more information: www.watts.com/prop65

Figure 1

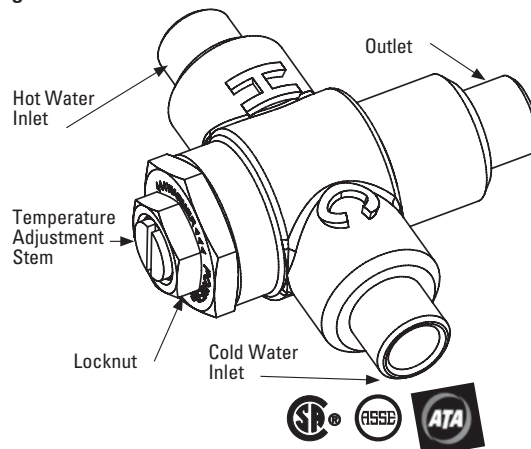
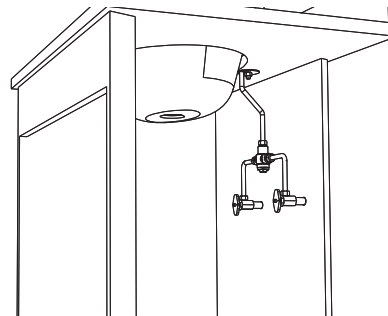

Figure 2: Typical Installation



To Adjust Temperature ■

1. Loosen locknut.
2. Turn on fixture and run water for at least two (2) minutes to allow supply temperature to stabilize.
3. Turn temperature stem counter-clockwise for hotter or clockwise for colder outlet temperature.
4. Tighten locknut to prevent accidental or unauthorized temperature adjustment.
5. Re-check outlet temperature.

Repair Kit ■

Motor Repair Kit..... 480-270

Plug-in Infrared Lavatory Sensor Installation

WILLOUGHBY INDUSTRIES
INFRARED
LAVATORY SENSOR

PART#: **700150**
24V AC System Infrared Sensor

DETECTION AND ACTIVATION

- When the sensor detects a user, a slow-flashing red light appears in the sensor window.
- After 1-2 seconds of detection, the light flashes rapidly, the sensor immediately activates the solenoid valve, beginning water flow.
- The valve remains open while the user is detected.
- The valve closes when the user is no longer detected.
- The sensor is set to activate the solenoid valve for a maximum of 30 seconds before automatically shutting off.

Note: Sensor range is factory preset to 20";
Optional range adjustment remote available
to adjust range from 1" min. to 30" max.
(**SEE FIG. 2**).

INSTALLATION AND OPERATION MANUAL

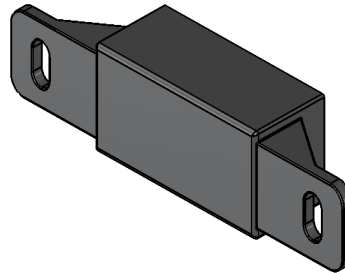

INSTALLATION AND REPLACEMENT

- 1) Disconnect the 24V AC power at either the transformer or fuse box.
- 2) Remove top cover to expose sensors (**SEE FIG. 1**)
- 3) Install the new sensor with arrow pointing upwards.
- 4) Connect the red male power cable to the female connector on the sensor (**SEE FIG. 3**).
- 5) Connect the black female solenoid cable to the male connector on the sensor.
- 6) Replace the top cover removed in Step 2.
- 7) Reconnect the power.

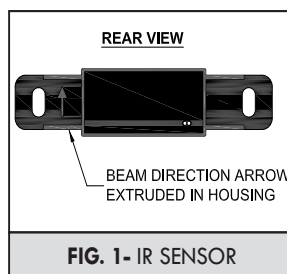

FIG. 1- IR SENSOR

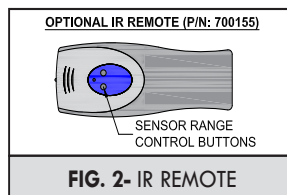

FIG. 2- IR REMOTE

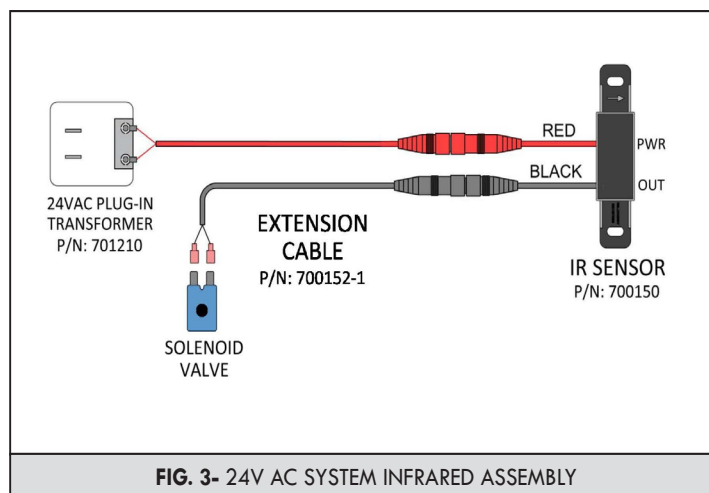

FIG. 3- 24V AC SYSTEM INFRARED ASSEMBLY



1.800.428.4065 TOLL FREE | www.willoughby-ind.com

Battery Operated Infrared Lavatory Sensor Installation

WILLOUGHBY INDUSTRIES INFRARED LAVATORY SENSOR

PART#: **700250**
(BO) Battery Operated Infrared

DETECTION AND ACTIVATION

- When the sensor detects a user, a slow-flashing red light appears in the sensor window.
- After 1-2 seconds of detection, the light flashes rapidly, the sensor immediately activates the latching solenoid valve, beginning water flow.
- The valve remains open while the user is detected.
- The valve closes when the user is no longer detected.
- The sensor is set to activate the latching solenoid valve for a maximum of 30 seconds before automatically shutting off.

Note: Sensor range is factory preset to 20";
Optional range adjustment remote available to adjust range from 1" min. to 30" max.
(SEE FIG. 2).

INSTALLATION AND OPERATION MANUAL

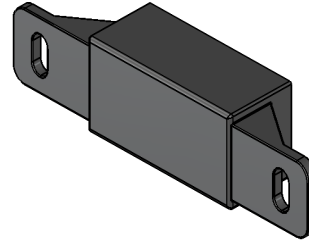

INSTALLATION AND REPLACEMENT

- 1) Remove the lavatory top cover to expose the sensors and battery pack.
- 2) Disconnect battery pack.
- 3) Install the new sensor. Make sure the sensor arrow is pointing up (SEE FIG. 1).
- 4) Connect the red male power cable to the female connector on the sensor (SEE FIG. 3).
- 5) Connect the black female valve coil cable to the male connector on the sensor (SEE FIG. 3).
- 6) Replace lavatory top cover removed in Step 1.
- 7) Reconnect battery pack.

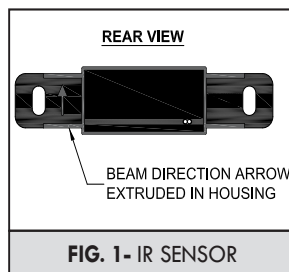

FIG. 1- IR SENSOR

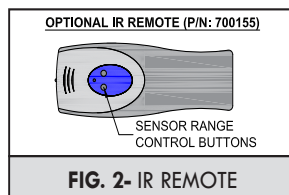

FIG. 2- IR REMOTE

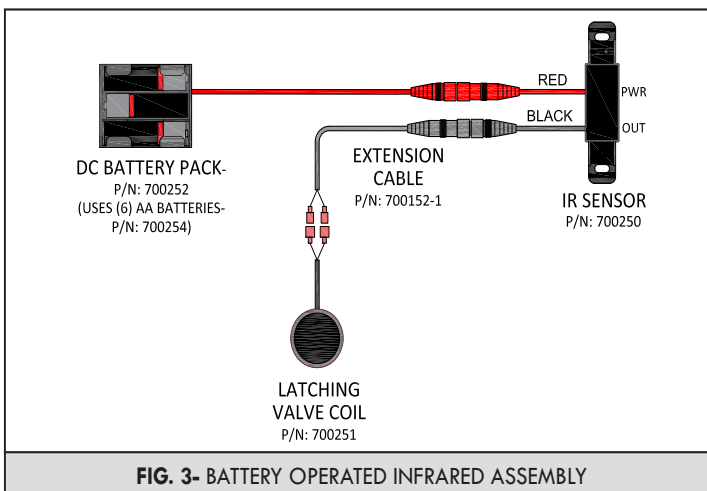
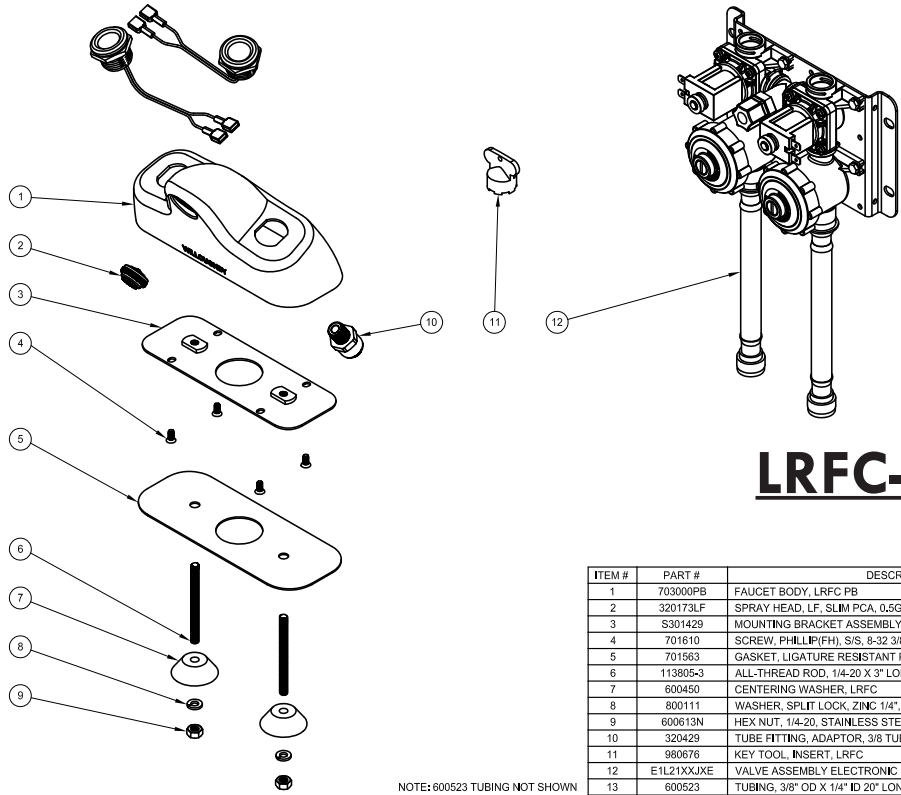

FIG. 3- BATTERY OPERATED INFRARED ASSEMBLY



1.800.428.4065 TOLL FREE | www.willoughby-ind.com

Faucet Part Numbers



LRFC-PZPB

ITEM #	PART #	DESCRIPTION	QTY.
1	703000PB	FAUCET BODY, LRFC PB	1
2	320173LF	SPRAY HEAD, LF, SLIM PCA, 0.5GPM	1
3	S301429	MOUNTING BRACKET ASSEMBLY FOR LRFC-PB	1
4	701610	SCREW, PHILLIP(FH), S/S, 8-32 3/8"	2
5	701563	GASKET, LIGATURE RESISTANT PUSH BUTTON FAUCET	1
6	113805-3	ALL-THREAD ROD, 1/4-20 X 3" LONG	2
7	600450	CENTERING WASHER, LRFC	2
8	800111	WASHER, SPLIT LOCK, ZINC 1/4", S/S	1
9	600613N	HEX NUT, 1/4-20, STAINLESS STEEL	1
10	320429	TUBE FITTING, ADAPTOR, 3/8 TUBE X 1/4 MPT	1
11	980676	KEY TOOL, INSERT, LRFC	1
12	E1L21XXJXE	VALVE ASSEMBLY ELECTRONIC DUAL TEMP-NFC-LEAD FREE	1
13	600523	TUBING, 3/8" OD X 1/4" ID 20" LONG	1

NOTE: 600523 TUBING NOT SHOWN

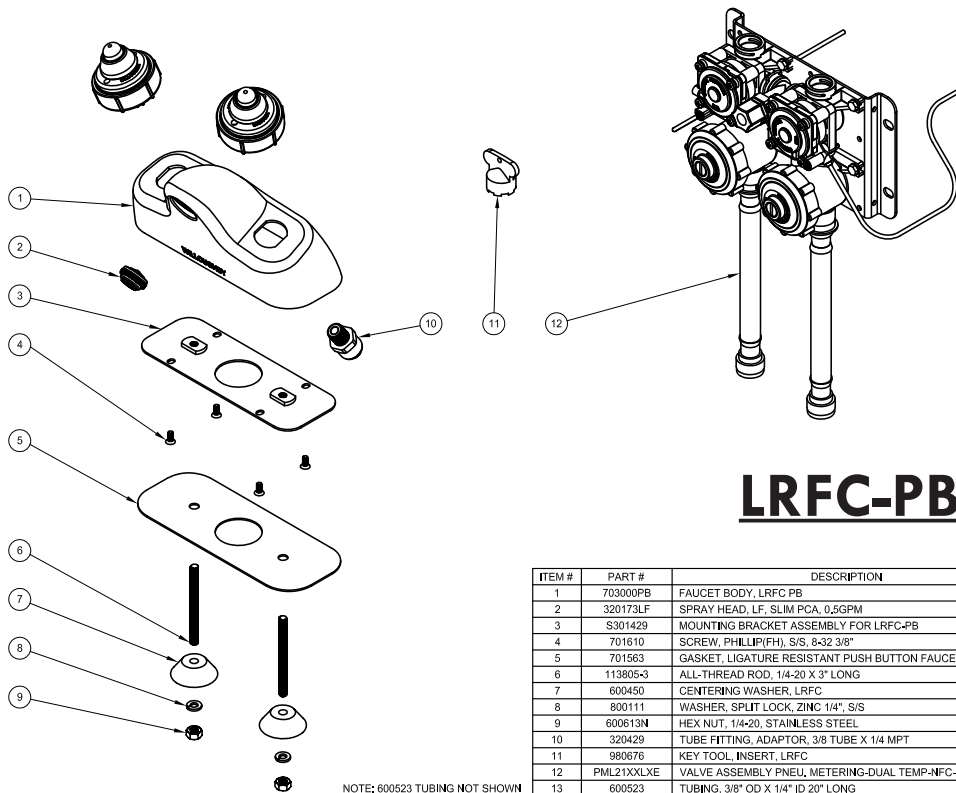

LRFC-PBH

ITEM #	PART #	DESCRIPTION	QTY.
1	703000PB	FAUCET BODY, LRFC PB	1
2	320173LF	SPRAY HEAD, LF, SLIM PCA, 0.5GPM	1
3	S301429	MOUNTING BRACKET ASSEMBLY FOR LRFC-PB	1
4	701610	SCREW, PHILLIP(FH), S/S, 8-32 3/8"	2
5	701563	GASKET, LIGATURE RESISTANT PUSH BUTTON FAUCET	1
6	113805-3	ALL-THREAD ROD, 1/4-20 X 3" LONG	2
7	600450	CENTERING WASHER, LRFC	2
8	800111	WASHER, SPLIT LOCK, ZINC 1/4", S/S	1
9	600613N	HEX NUT, 1/4-20, STAINLESS STEEL	1
10	320429	TUBE FITTING, ADAPTOR, 3/8 TUBE X 1/4 MPT	1
11	980676	KEY TOOL, INSERT, LRFC	1
12	PML21XXLXE	VALVE ASSEMBLY PNEU, METERING-DUAL TEMP-NFC-LEAD FREE	1
13	600523	TUBING, 3/8" OD X 1/4" ID 20" LONG	1

NOTE: 600523 TUBING NOT SHOWN

Faucet Part Numbers (cont.)

LRFC-IR

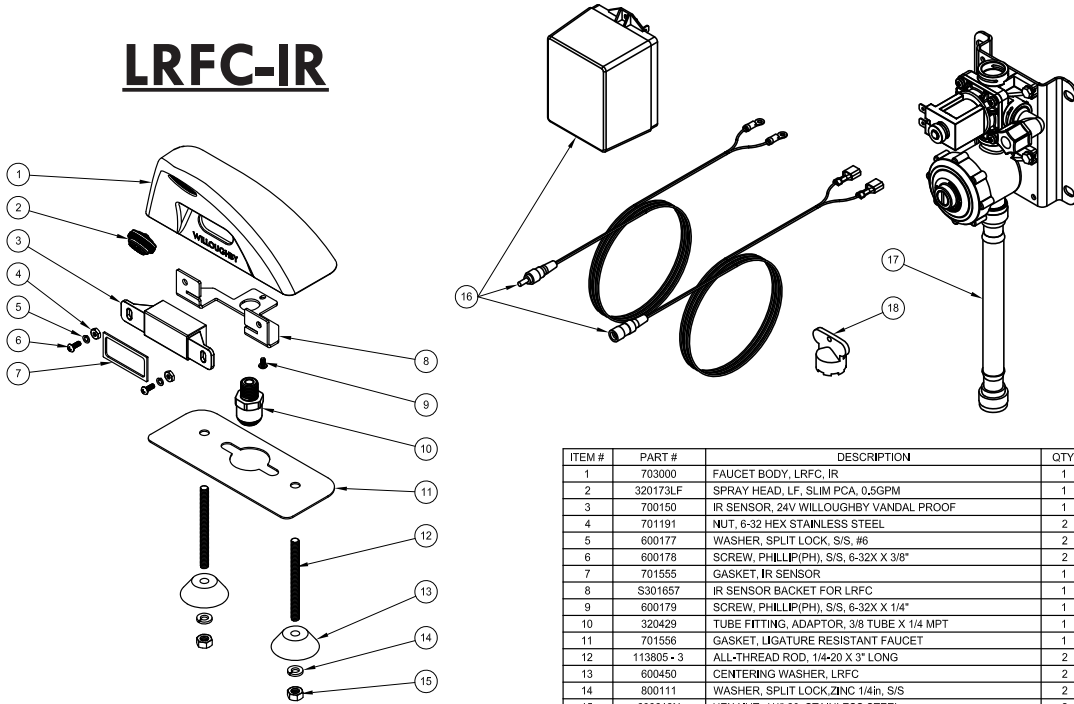

NOTE: 600523 TUBING NOT SHOWN

ITEM #	PART #	DESCRIPTION	QTY.
1	703000	FAUCET BODY, LRFC, IR	1
2	320173LF	SPRAY HEAD, LF, SLIM PCA, 0.5GPM	1
3	700150	IR SENSOR, 24V WILLOUGHBY VANDAL PROOF	1
4	701191	NUT, 6-32 HEX STAINLESS STEEL	2
5	600177	WASHER, SPLIT LOCK, S/S, #6	2
6	600178	SCREW, PHILLIP(PH), S/S, 6-32X X 3/8"	2
7	701555	GASKET, IR SENSOR	1
8	S301657	IR SENSOR BASKET FOR LRFC	1
9	600179	SCREW, PHILLIP(PH), S/S, 6-32X X 1/4"	1
10	320429	TUBE FITTING, ADAPTOR, 3/8 TUBE X 1/4 MPT	1
11	701556	GASKET, LIGATURE RESISTANT FAUCET	1
12	113805 - 3	ALL-THREAD ROD, 1/4-20 X 3" LONG	2
13	600450	CENTERING WASHER, LRFC	2
14	800111	WASHER, SPLIT LOCK, ZINC 1/4in, S/S	2
15	600613N	HEX NUT, 1/4"-20, STAINLESS STEEL	2
16	700156-1	POWER SUPPLY, 1-STATION IR SENSOR, 24V, ADJUSTABLE	1
17	E1L11XXXXE	VALVE ASSY ELECTRONIC SINGLE TEMP - NFC - LEAD FREE	1
18	980676	KEY TOOL, INSERT, LRFC	1
19	600523	TUBING, 3/8" OD X 1/4" ID 20" LONG	1

LRFC-BO

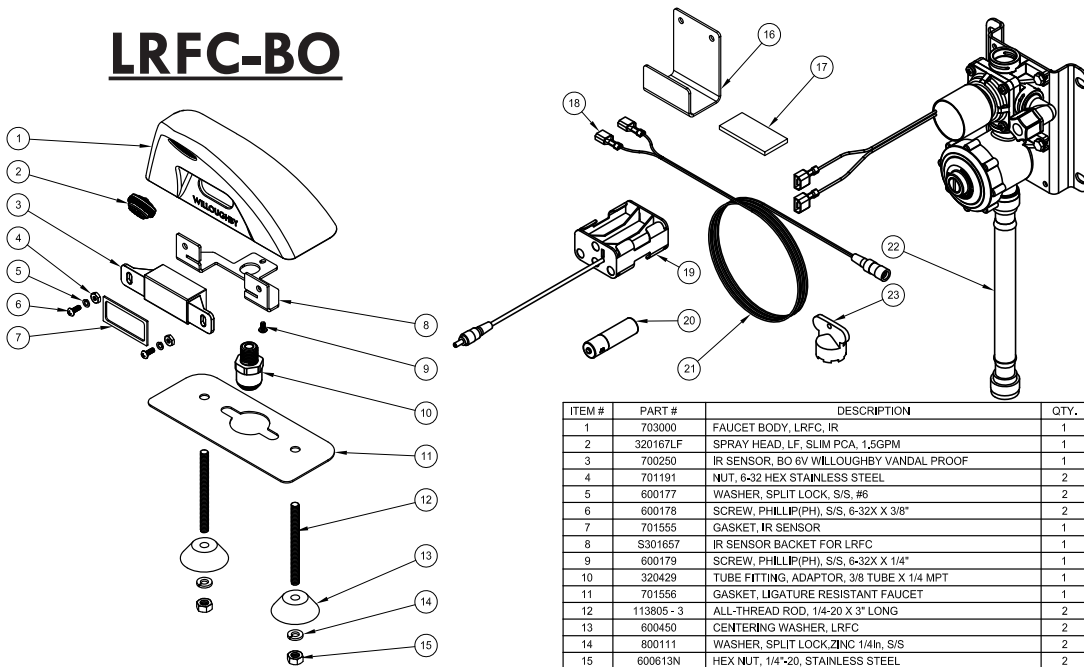

NOTE: 600523 TUBING NOT SHOWN

ITEM #	PART #	DESCRIPTION	QTY.
1	703000	FAUCET BODY, LRFC, IR	1
2	320167LF	SPRAY HEAD, LF, SLIM PCA, 1.5GPM	1
3	700250	IR SENSOR, BO 6V WILLOUGHBY VANDAL PROOF	1
4	701191	NUT, 6-32 HEX STAINLESS STEEL	2
5	600177	WASHER, SPLIT LOCK, S/S, #6	2
6	600178	SCREW, PHILLIP(PH), S/S, 6-32X X 3/8"	2
7	701555	GASKET, IR SENSOR	1
8	S301657	IR SENSOR BASKET FOR LRFC	1
9	600179	SCREW, PHILLIP(PH), S/S, 6-32X X 1/4"	1
10	320429	TUBE FITTING, ADAPTOR, 3/8 TUBE X 1/4 MPT	1
11	701556	GASKET, LIGATURE RESISTANT FAUCET	1
12	113805 - 3	ALL-THREAD ROD, 1/4-20 X 3" LONG	2
13	600450	CENTERING WASHER, LRFC	2
14	800111	WASHER, SPLIT LOCK, ZINC 1/4in, S/S	2
15	600613N	HEX NUT, 1/4"-20, STAINLESS STEEL	2
16	S600675	BATTERY PACK CRADLE	1
17	701570	2" WIDE VELCRO STRIP, 1" LONG	1
18	600830	CONNECTOR, 1/4" FEM, 18-22 AWG, FI	1
19	700252	BATTERY PACK, DC IR BO VALVE SYSTEM	1
20	700254	BATTERY, AA	6
21	700152-1	CABLE, IR, BLACK, 8', SEALED	1
22	EBL11XXXXE	VALVE ASSY, BATTERY OPERATED SINGLE TEMP - NFC - LEAD FREE	1
23	980676	KEY TOOL, INSERT, LRFC	1
24	600523	TUBING, 3/8" OD X 1/4" ID 20" LONG	1

Troubleshooting - Infrared Sensors

- I. Faucet does not function (red light does not appear when user steps in front of sensor)
 - A. No power to sensor. Make certain that power is on. Check transformer leads and connections. Repair or replace as necessary.
 - B. Willoughby 700150 IR Sensor not operating. Replace Willoughby 700150 IR Sensor.

- II. Faucet does not function (red light appears when user steps in front of sensor and solenoid does not click)
 - A. Debris in solenoid; disassemble, clean, and flush.
 - B. Solenoid not wired correctly; check solenoid connections.
 - C. Solenoid problem; replace solenoid.

- III. No water when activated (valve clicks)
 - A. Make certain that water is turned on.
 - B. Valve clogged. Clean or replace filter.

- IV. Very low flow or slow dribble
 - A. Check supply stop(s); open if closed.
 - B. Debris in filter; remove, clean, and reinstall.
 - C. Debris in aerator or spray head; remove, clean and reinstall.
 - D. Disassemble solenoid; clean and flush.

- V. Continues to run (with power on and red light flashing)
 - A. Non-permanent target in range after user leaves. Remove non-permanent target. If this target is a new permanent target (i.e., a new wall or partition), turn off 24 volt power for fifteen (15) seconds. Turn power back on and let the sensor complete start-up mode.
 - B. Sensor failure; replace sensor.

- VI. Continues to run (even with power disconnected)
 - A. Solenoid valve installed backwards.
 - B. Debris in solenoid, won't close properly; remove operator and clean. Reassemble in the same manner.

Troubleshooting - Electronic Valves

The two most common reasons an electronic valve does not operate properly are: (1) lack of power or (2) lack of water pressure. The following steps should be used as a guide in identifying the problem of a malfunctioning electronic valve.

- I. Lack of power
 - A. Verify that the 110V GFCI outlet has power
 - B. Check all connections to ensure they have been made correctly:
 1. Cable connecting the valve coil and the timer or IR sensor
 2. Cable connecting the timer and the pushbutton (Piezo only)
 3. Cable connecting the timing device and the 24VAC transformer
 4. The 24VAC transformer and the 110V GFCI outlet
 - C. If the valve is wired correctly, the solenoid will make a “click” sound indicating that the valve has been actuated. The electronic valve is actuated by either the piezo pushbutton or the triggering of the infrared sensor (see the Start-Up Instructions for Infrared Sensors in this manual).

- II. Lack of water pressure
 - A. Check the supply to the rough-ins
 - B. Make sure the screwdriver stops are in the open position
 - C. Water pressure needs to be above 35psi to operate the valve
 1. If the water supply pressure is above 35psi but not exiting the valve:
 - a. Clean any debris from the screen on the inlet side of the solenoid valve body
 - b. Remove the screws on the valve body and clean any debris from the diaphragm

After all of the above steps have been followed, if there is still no water coming out of the spray head, there may be a damaged or defective part (see installation notice in the beginning of this manual).

Troubleshooting - Pneumatic Valves

- I. Valve will not open or deliver water
 - A. Check the plastic tubing that runs from the pushbutton actuator to the pneumatic valve for air leaks.
 - B. Make sure the checkstop on the supply to the valve is fully open. Do not partially close the checkstop for any reason as it is not a throttling valve. The checkstop should be fully open (normal operation) or fully closed (when servicing the valve).
 - C. Close checkstop and then inspect the strainer in the supply line (installed after the checkstop) to make sure the strainer is not blocked or partially blocked, prohibiting water flow.

- II. Valve will not shut off
 - A. Separate valve motor from casting by removing the four (4) #8 screws.
 - B. Inspect the water diaphragm assembly to see if bypass hole in diaphragm is blocked. Remove any debris by blowing on diaphragm or using force of air. Do not use any tool (such as straight pin) to remove any debris. Enlarging the hole will shorten or make for erratic cycling.
 - C. Check the metering screw on the timer assembly to make sure the adjustment screw is not closed too tightly. To reset, back out adjustment screw (counterclockwise) about 1-1/2" turns, and adjust for the desired cycle.

- III. Valve continues to trickle or partially deliver water after cycle is over
 - A. Inspect seating area on valve base to make sure no debris, pitting, or scoring is present.
 - B. Clean seat or replace seat as necessary.
 - C. Inspect seating area of diaphragm for debris, clean as necessary. If debris has caused permanent indentations in the rubber, it may have to be replaced.

After all of the above steps have been followed, if there is still no water coming out of the spray head, there may be a damaged or defective part (see installation notice in the beginning of this

Care and Maintenance

Solid Surface Care

Surfaces may be easily cleaned using conventional cleaning agents such as an ammonia based liquid cleaner, (glass cleaner).

Dry stains on a matte finish can be removed with a 3M Scotch-Brite gray scouring pad or a mild abrasive cleaner.

Burns or scorches can be removed by sanding with coarse grit sandpaper followed by finer grit (220) sandpaper. Follow sanding with a 3M Scotch-Brite gray pad (or equivalent) to match finish of sanding area to surrounding area. A final buffing may be required on polished surfaces. Accidental nicks or chips can be repaired with special patch kits available in all colors.

Avoid exposing surfaces to strong chemicals such as acetone's; paint removers and sulfuric acid or hydrochloric chemical cleaners. Exposure to strong chemicals may result in permanent damage to surfaces.

Stainless Steel Care

Stainless Steels are basically alloys of iron and chromium and are corrosion resistant. Stainless steel has a bright surface that is easy to clean and is free from oxides. Therefore, cleaning of stainless steel is relatively simple and easy if done on a regular basis.

Frequency of cleaning should depend on the rate at which the fixture becomes dirty. Remember that fresh (soft) deposits of all kinds are relatively easy to remove, while removing older (hard) deposits are much more difficult. Establish a cleaning SCHEDULE.

Routine cleaning should involve ordinary soap or detergent and water, applied with a sponge, brush or cloth. Baking soda, borax or any of several non-abrasive commercial cleansing agents can help hasten the cleaning action. after scrubbing, rinse THOROUGHLY and wipe dry.

DO NOT use common steel wool, scouring pads, scrapers, wire brushes, files or other steel tools to clean stainless steel. Such items will scratch the surface or leave small particles of iron imbedded in the surface, which will eventually rust and stain the surface - even appearing as if the stainless itself was rusting.

Certain chemical compounds, if used on stainless steel, can give the appearance of rust and if allowed to stand for long periods of time, can pit the surface of even stainless. Products containing hydrochloric acid, muriatic acid or potassium hydrochloride can ruin the surface.

DRAWING: Pneumatic Valve Detail

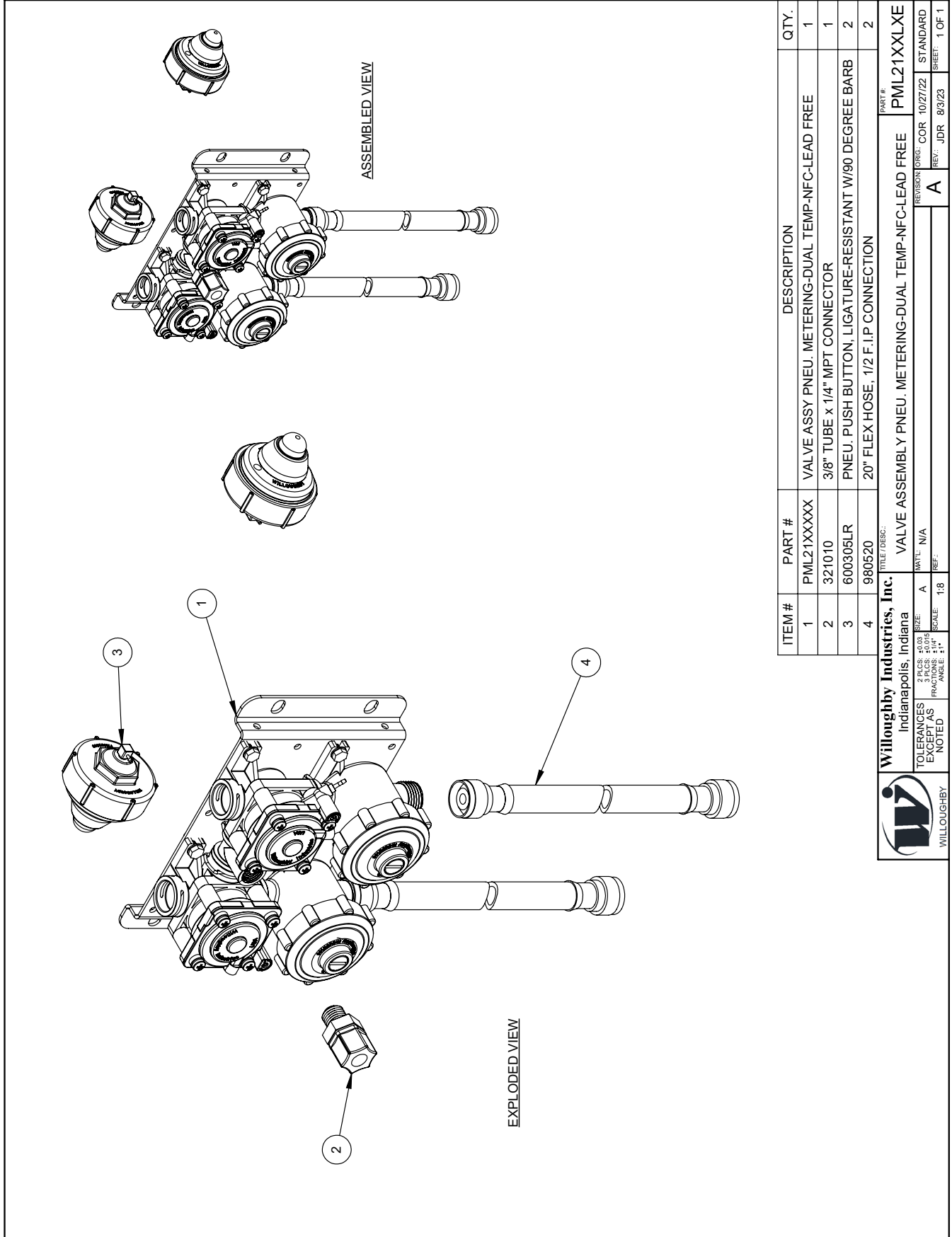

ITEM #	PART #	DESCRIPTION	QTY.
1	PML21XXXXX	VALVE ASSY PNEU. METERING-DUAL TEMP-NFC-LEAD FREE	1
2	321010	3/8" TUBE x 1/4" MPT CONNECTOR	1
3	600305LR	PNEU. PUSH BUTTON, LIGATURE-RESISTANT W/90 DEGREE BARB	2
4	980520	20" FLEX HOSE, 1/2 F.I.P CONNECTION	2

Willoughby Industries, Inc.
Indianapolis, Indiana

TOLERANCES EXCEPT AS NOTED
FRAGILE - HANDLE CAREFULLY

3 PLS. ±0.03
3 PLS. ±0.015
FRAGILE - HANDLE CAREFULLY

SCALE: 1:8

REF: A

WILLOUGHBY

REVISION: COR 10/27/22
REV.: JDR 8/3/23

PART # PML21XXLXE
STANDARD SHEET 1 OF 1

DRAWING: 24V Electronic Valve Detail

EXPLODED VIEW

ASSEMBLED VIEW

ITEM #	PART #	DESCRIPTION	QTY.
1	980501	PM1 VALVE BRACKET	1
2	980183	CHECKSTOP ASSEMBLY	1
3	980408PR	E1L VALVE ASSEMBLY - RIGHT PLUGGED PORT	1
4	980140	SPRING CLIP, ROUND	2
5	800133	#10-16 SELF TAP TYPE B HEX HEAD SCREW	4
6	980600A	VALVE FITTING ASSEMBLY, 3/8" ELBOW	1
7	980520	20" FLEX HOSE, 1/2 F.I.P. CONNECTION	1

TITLE / DESC:		VALVE ASSY ELECTRONIC SINGLE TEMP - NFC - LEAD FREE	
MATL:	N/A	REVISION ORG:	EEF 2/15/15
REF:		REV:	NAL 11/30/20
PART #:		E1L11XXXXE	

Willoughby Industries, Inc.
Indianapolis, Indiana

TOLERANCES EXCEPT AS NOTED
 3 PLS: ±0.03
 5 PLS: ±0.015
 FRAC: 1/16" SCALE: 1" = 1"

WILLOUGHBY

DRAWING: 9V Battery Operated Valve Detail

EXPLODED VIEW

ASSEMBLED VIEW

ITEM #	PART #	DESCRIPTION	QTY.
1	980501	PM1 VALVE BRACKET	1
2	980183	CHECKSTOP ASSEMBLY	1
3	980416PR	VALVE ASSY, BATTERY OPERATED, RH PLUGGED PORT	1
4	980140	SPRING CLIP, ROUND	2
5	800133	#10-16 SELF TAP TYPE B HEX HEAD SCREW	4
6	980600A	VALVE FITTING ASSEMBLY, 3/8" ELBOW	1
7	980520	20" FLEX HOSE, 1/2 F.I.P. CONNECTION	1

Willoughby Industries, Inc.
Indianapolis, Indiana

TOLERANCES: 2 PLS: ±0.03, 3 PLS: ±0.015, EXCEPT AS NOTED
FRAMES: 1/8" MIN. ANGLE: 1°

MATL: N/A
REV: A
SCALE: 1:4

REVISION: NAL 11/30/20
REV: NAL 11/30/20

PART #: **EBL11XXXXE**

VALVE ASSY, BATTERY OPERATED SINGLE TEMP - NFC - LEAD FREE

STANDARD SHEET: 1 OF 1

DRAWING: Pneumatic Push Button Detail

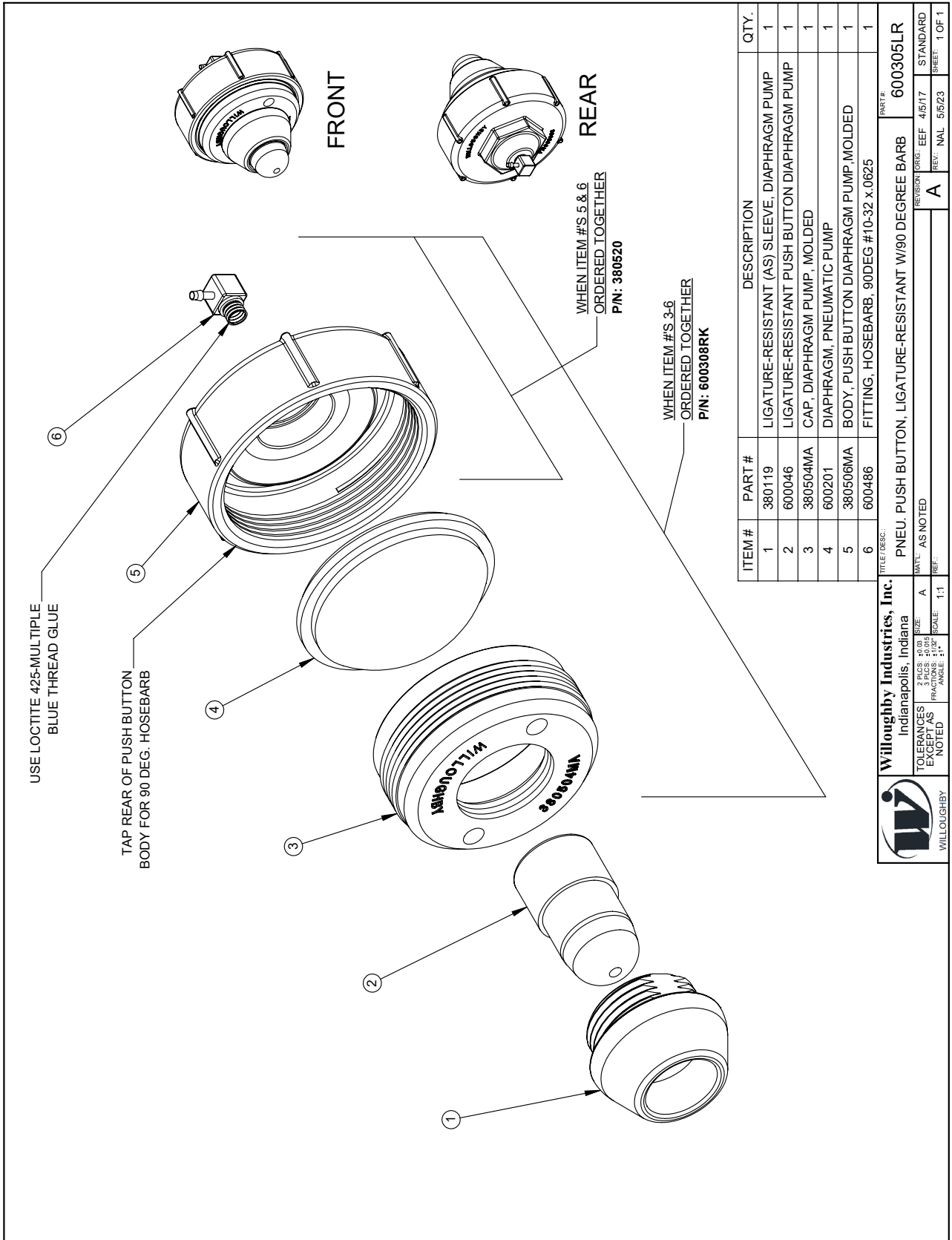

DRAWING: Pneumatic Push Button Detail

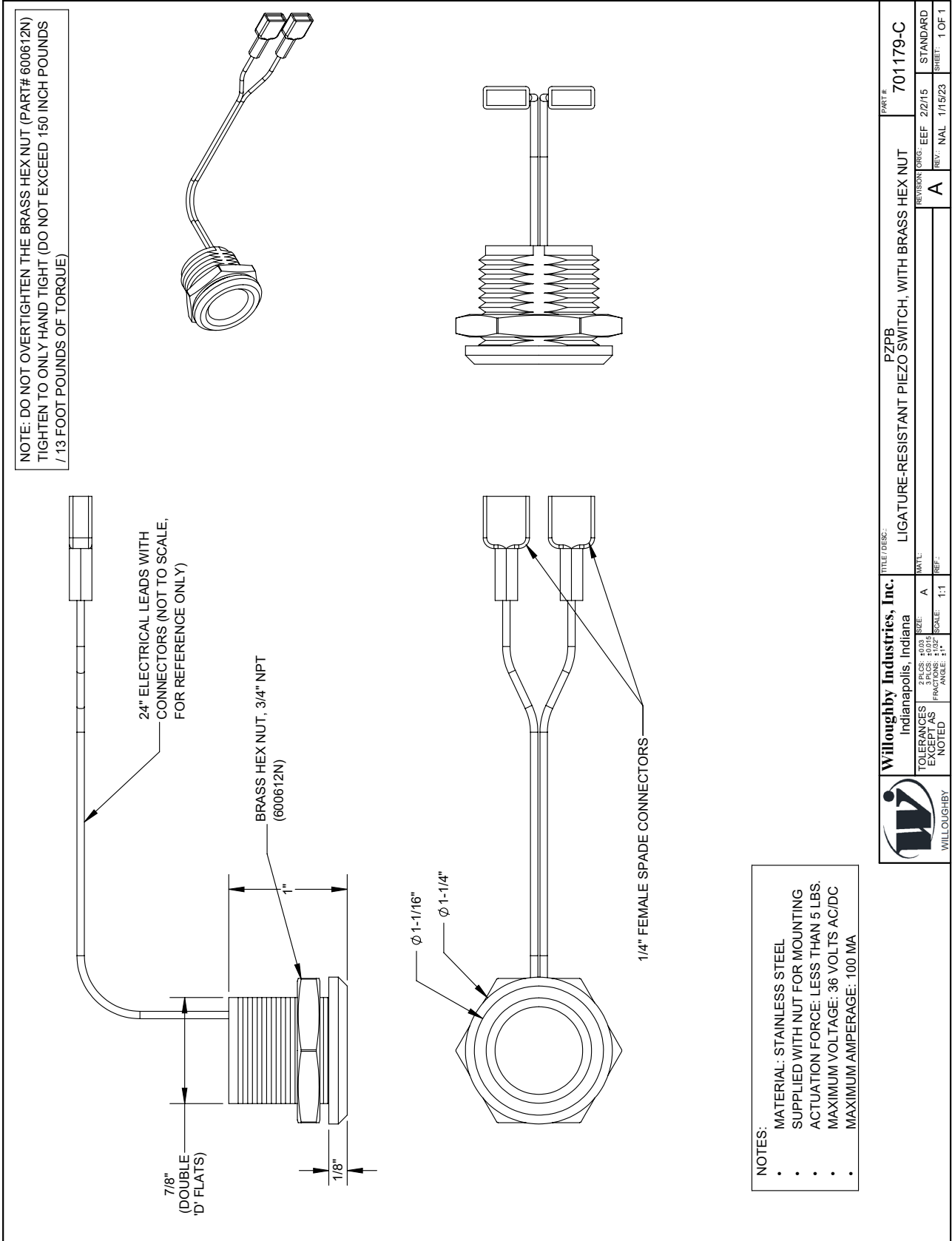

Warranty

Solid surface products are a homogenous blend of resins, mineral filler and colorant manufactured for panels, molded and/or shaped products and components. Solid surface products provide a luxurious appearance with the durability of stain proof, impact resistant, burn resistant material with the ease of maintenance and cleaning.

Willoughby Industries, Inc. warrants to commercial and institutional purchasers only that each unit will be free from defects in workmanship and materials under normal use and service upon the following terms and conditions. The period during which components are warranted as follows:

1. Solid surface components are warranted for 2 years from date of shipment.
2. All other components warranted for 1 year from date of shipment.

This warranty does not cover installation or any other labor charges and does not apply to any components damaged by accident, abuse, improper installation or improper maintenance. This warranty does not cover any installation that did not comply with national, state and local building, plumbing or electrical codes. The warranty is limited to replacing or repairing at manufacturer's option, transportation charges prepaid by the purchaser, any component or part which upon our inspection shall be deemed as defective within the limitations of this warranty. The replacement or repair of defective units as stated in this warranty shall constitute the sole remedy of the purchaser and the sole liability of Willoughby Industries, Inc. Willoughby Industries, Inc. shall not otherwise be liable under any indirect damages caused by defects in the repair or replacement thereof.

This warranty only extends to commercial and industrial purchasers and does not extend to any others, including consumer customers of commercial institutional purchasers. This warranty is in lieu of all other warranties, expressed or implied, including implied warranty of merchantability or fitness for a particular purpose or otherwise.