

Installation & Operation Manual

T4A Toilet Overflow Preventer w/ Automatic Reset

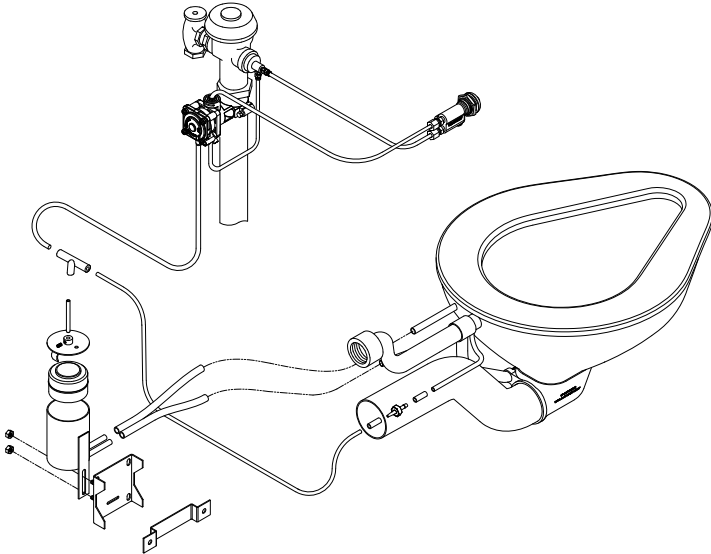

**T4A
(Auto-Reset)**

Table of Contents

Pre-Installation Information.....	3
General Discription	4
Physical Dimensions	5
Exploded-view w/BOM	6
Checking Contents	7
Installation Instructions	8
Care and Maintenance	9
Troubleshooting Guide	10
Troubleshooting Guide Diagram	13
Warranty.....	14



Willoughby Industries, Inc.

5105 West 78th Street

Indianapolis, IN 46268

Toll Free: (800) 428-4065

Local: (317) 875-0830

Fax: (317) 875-0837

www.willoughby-ind.com

WILLOUGHBY

Rev. 10/2019

MADE IN THE U.S.A.



(Page left intentionally blank)

Pre-Installation Information

Installation notice!

Check Rough-In location **PRIOR** to installation

Flush lines thoroughly **PRIOR** to hook-up

When installing the **Willoughby Industries' Top-4 Overflow Preventer w/ Automatic Reset:**

Before step 1 of the installation instructions, ensure that rough-ins are in the correct location.

The valve assembly, including the spray head, **MUST NOT BE** connected until *after* all lines have been flushed to remove the small particles of debris that are inherent with new construction projects and all chemicals that are used in flushing are purged from the system.

Chemicals used in flushing plumbing systems can attack the internal components of the valve and spray head and severely damage them, so any flushing of the system must be followed by a full flushing with pure water to clear any harsh chemicals remaining in the system. Debris in the system if allowed to enter the valve assembly and spray head can cause poor performance or outright failure.

Again **DO NOT** attempt to connect the valve assembly and spray head until *after* all flushing is complete and pure water is the only media that will be passing through the system. Damage to the valve assembly or spray head caused by harsh chemicals or debris will not be covered by the manufacturer's warranty.

Installation notice!

Check Rough-In location **PRIOR** to installation

Flush lines thoroughly **PRIOR** to hook-up

General Description

In normal operation (toilet bowl un-obstructed) the auto-reset float is at rest inside the float tank assembly permitting air flow thru the vacuum generator and allowing normal flush cycles. When the toilet bowl is intentionally plugged or otherwise obstructed, the water level in the bowl rises to the lower overflow sensing port and begins to fill the float tank. As the water level in the toilet continues to rise, the float inside the tank also rises and seals against the stainless steel tube in the float tank cover. This closes the air flow to the vacuum generator and causes vacuum to build at the Top-4 valve and shuts off the flush valve.

This vacuum is held within the system by the action of the automotive type check valve and the float seal, as long as the water level in the toilet bowl is near an overflow condition. Additional flushes are prevented by vacuum retained in the Top-4 valve.

Once the obstruction is cleared from the toilet bowl, water then drains back from the float tank thru the flexible tubes connected to the overflow sensing port. This drain-back allows the float to drop to its "at rest position" uncovering the end of the stainless steel tube in the tank cover. This opens the vacuum lines from the Top-4 valve to atmosphere and automatically re-sets the valve for another flush cycle.

Exploded-view w/BOM- Valve Assembly

ITEM #	SUB-ASSY#	PART #	DESCRIPTION	QTY.
1	N/A	380841	FITTING HOSEBARB #10-32 x.0625	1
2	980315	980160	MAGNET CUP & DIAPHRAGM ASSEMBLY	1
3		980132	MAGNET, PNEUMATIC METERING VALVE	1
4	N/A	380802M	BODY, MOLDED WI PNEU. MTRG.	1
5	N/A	980127	O-RING M1.5x32 BUNA-70	1
6	N/A	980136	SPRING, WATER SIDE DIAPHRAGM	1
7	980310	980161	BUMPER, WATER SIDE ACTUATOR DISC	1
8		980125	DISK, WATER SIDE ACTUATING	1
9	980305	980128	3-PRONG VALVE SEAT ADAPTOR	1
10		980129	DIAPHRAGM - WATER SIDE - PM/EL	1
11	N/A	980126	BARRIER CUP	1
12	N/A	980001A	#8-32 x 1 1/4" SCREW	4
13	N/A	380801M	AIR SIDE TOP COVER	1
15	N/A	980426B	TOP 4 BASE, SUB-ASSEMBLY	1

NOTE: REPAIR KIT ORDERING #'S ARE LISTED IN THE EXPLODED VIEW.

NOTE: PARTS LISTED IN THE PVK REPAIR KITS ARE NOT SOLD INDIVIDUALLY

NOTE: ITEMS IN PVK-2 AND PVK-3 ARE AVAILABLE IN KIT FORM ONLY. ITEMS CANNOT BE PURCHASED INDIVIDUALLY

PVK-2 DIAPHRAGM KIT (PARTS: 10-14)

PVK-3 DIAPHRAGM KIT (PARTS: 9, 10)

ASSEMBLED VALVE

P/N: 980426B

Willoughby Industries, Inc. Indianapolis, Indiana		TITLE / DESC: VALVE ASSEMBLY, T4-AUTO RESET		PART # 980402T-B	
TOLERANCES FRACTIONS AS NOTED	UNITS: SEE BOM	REV: A	ORIG: TRB 10/18/12	STANDARD	1 OF 1
SCALE: 1:1	ANGLE: 3°	SCALE: 1:2	REV: MW 10/30/17	SHEET	

Check Contents

- Separate all parts from packaging and make sure all parts are accounted for before discarding any packaging material. If any parts are missing, do not attempt to install T4A Toilet Overflow Preventer w/ Automatic Reset until you obtain the missing parts.

NOTE: Before beginning installation, all supply, drain and waste piping for the T4A Toilet Overflow Preventer w/ Automatic Reset must be completed according to specified rough-ins. If you have not received rough-in details, please contact Willoughby Industries, Inc. (800) 428-4065

IMPORTANT: Flush all the water supply lines before making connections.

Installation Instructions

1. Mount the TOP-4 valve and bracket onto the flush valve with the u-bolt and nuts as seen on the drawing number P091037A.
2. Attach the piece of tubing (that s already connected to the TOP-4 valve) to the open port on the rubber tee fitting (see drawing P091037A).
3. Adjust the float tank height by loosening the two nuts holding the tank in place and moving the tank up or down. The height of the tank is correct when the center tube at the bottom of the tank is level to 1/8" above the lower steel overflow tube found on the back of the toilet. Tighten the two nuts to hold the float tank in place. See drawing P091037A if needed.
4. Adjust the float stem to the appropriate height. First loosen the set screw that is holding the float stem in place. Allow the float stem to lower all the way down into the float tank. Raise the float stem 3/16" - 1/4" above its bottomed out position, and lock the float stem in place by tightening the set screw. See drawing P091037A if needed.
5. The TOP-4 valve is installed in the hydraulic flush valve's high pressure line. This line is identified with a letter "O" on a Sloan® flush valve and push button for the flush valve. After this line has been connected between the flush valve and the push button, cut it at a location that will allow both of the cut ends to reach the TOP-4 valve. The tube that connects the low pressure (letter "L" on a Sloan® valve) fittings on the flush valve and push button will remain unchanged.
6. The line from the flush valve (letter "O" on a Sloan® valve) connects to the elbow tube fitting on the bottom of the TOP-4 valve and the line from the flush valve push button (letter "O" on a Sloan® valve) connects to the straight fitting on the side of the TOP-4 valve (see drawing P091037A).

NOTE: If the plastic fittings are taken apart for any reason, use **ONLY** thread tape on the plastic threads to reseal them. **DO NOT USE ANY OTHER THREAD SEALERS OR THREAD LOCKERS ON THE PLASTIC THREADS.** Thread sealers and thread lockers will attack the black plastic parts, If you have any questions, contact Willoughby Industries at: (317) 638-2381.

Care and Maintenance

There is no regularly scheduled maintenance required for the "Auto-Reset" system. The system should be visually checked for cracks in the flexible vacuum lines during normal maintenance inspections of other plumbing systems. If any cracking or damage is found, it is recommended that all flexible vacuum lines and connectors be replaced at that time.

Troubleshooting Guide

While the "Auto-Reset" feature is designed for a trouble-free service life matching the standard "Top-4" overflow prevention, problems can arise in any system. A few simple checks can be made to diagnose problems that may occur.

SYMPTOMS:

- A) Unit allows a limited number of overflows prior to stopping them.
- B) Unit continues to flush with an overflow condition.
- C) Unit fails to flush after toilet obstruction is removed.
- D) Unit flushes once but fails to re-flush although no overflow is present.
- E) Too high/low overflow trip level.

- A) Unit allows a limited number of overflows prior to stopping them.

CAUSE:

The visible overflow sensor port is blocked. This causes the water level to rise above this port and not allow overflow water to reach the float tank normally. The water level continues to rise with each flush until it reaches the level of the back-up sensor port located inaccessibly under the toilet rim. When the water level is high enough to drain to the float tank through this back-up port, the float inside the tank will rise sufficiently to trigger the system and prevent further flushes.

REMEDY: Remove blockage of the main overflow sensor port.

- B) Unit continues to flush with an overflow condition.

CAUSE:

REMEDY: Varied. Several items will need to be checked at this point:

- 1) Faulty Top-4 pneumatic valve - Consult the O & M manual for this valve and service as needed.
- 2) Low water delivery pressure to the unit - The system is designed to operate above 35 PSI inlet pressure to insure enough vacuum supply to the overflow prevention system. Correct as required.
- 3) Blocked overflow lines to the float tank - Visually inspect the two transparent lines connected to the overflow tank for any obstructions. If these lines are blocked, overflow water won't be sufficient to raise the float inside the tank enough to prevent further flushes. Remove the lines by gently pulling on them and clean as required. Replace the lines in the same position as they were installed and check the system for proper operation.
- 4) Float tank cover ajar or completely off - Replace cover by firmly pressing it into the tank with the spring fingers pointing downward. Continue to press into tank until fully seated.
- 5) Stuck float in tank - Remove tank cover by gently prying off with a small screwdriver. Carefully remove float, clean with water & a mild detergent, and inspect float for any damage. Remove any debris from float tank and clean any sludge or residue. Replace float in the tank with the soft black bubble pointing upward. Replace float tank cover as in Step B-4.

Troubleshooting Guide (cont.)

B) Unit continues to flush with an overflow condition (continued)

- 6) *Damaged float stem - Remove tank cover per Step B-5 and turn cover over to expose the stainless steel tube on the underside. Inspect tube and its beveled end for any nicks, burrs, or dents. Replace as required. The beveled end may be carefully re-shaped with a small grindstone to remove any irregularities. Take care not to let dirt or debris from grinding enter the tube. Remove the soft ¼" tee from the tube by gently pulling from stem. Do not allow stem to be pulled from the tank cover. Using compressed air, thoroughly clean the inside & outside of the stem prior to replacing the soft tee. If the stem has moved from its pre-set position in the cover, it must be re-positioned correctly before the unit will function properly. To re-set the stem, loosen the set screw on the collar welded to the cover. Slide the stem, beveled side down, approximately 1-1/8" thru the cover and install the cover/stem onto the float tank per Step 4. Gently push the stem deeper into the tank until light contact is made with the soft bubble on the float. Note the position of the stem and raise the stem 3/16 ~ 1/4 inch from this and tighten the set screw firmly. Replace the soft tee on the stem. The unit is ready for use. Failure to properly install the stem in the cover will result in false trips of the overflow prevention.*
- 7) *Out of adjustment float stem - Re-adjust per Step B-6.*
- 8) *Damaged or cut vacuum lines – Replace as needed. When replacing these lines, care must be taken to fully seat them into their connections. Failure to properly seat the flexible lines will cause the overflow prevention system to fail until all lines and connectors are properly installed.*
- 9) *Leaking vacuum connectors – Visually inspect each vacuum connector for signs of cracking or damage. Replace as needed. The same caution in Step B-8 applies to this step.*
- 10) *Defective vacuum check valve – Disconnect the check valve from the stainless steel tube on the toilet bowl. Remove vacuum check valve from the ¼" diameter tubing by carefully holding the tubing and steadily pulling the check valve from its tube connector. Flush the check valve by spraying WD-40 or equivalent, spraying the valve from the white stem of the valve. Using clean compressed air, dry the check valve thoroughly from the same side. Re-assemble the check valve to the ¼" O.D. tube, making sure the white side of the check valve is installed in the tubing leading to the overflow float tank. Re-install the check valve to the stainless steel tube, and check all vacuum tube connections for leaks. The unit should now work properly. If the unit still isn't functioning correctly, re-check all tube connections for proper tightness. If all connections are tight and leak-proof, the vacuum check valve must be replaced*

C) *Unit fails to flush after toilet obstruction is removed*

CAUSE:

- 1) *Stuck float in overflow tank – See Step B-5.*
- 2) *Water in vacuum lines – Disconnect the 1/8" O.D. tube from the Top-4 pneumatic valve, insure that the float tank is empty of water and the float is free. Flush unit several times to purge water from the vacuum lines. (NOTE: Disconnecting the vacuum lines from the pneumatic valve re-sets it to operational status.)*
- 3) *Obstructed float stem – Remove obstruction from float stem. See Step B-6 for disassembly and re-installation*

Troubleshooting Guide (cont.)

D) Unit flushes once but fails to re-flush although no overflow is present, but will flush after 10 to 30 seconds elapse.

CAUSE:

- 1) Float stem out of adjustment – See Step B-6 for adjustment.*
- 2) Partially obstructed float stem – Remove obstruction from float stem. See Step B-6 for disassembly and re-installation*

E) Too high/low overflow trip level.

CAUSE:

- 1) Float tank misaligned with overflow sensor port on toilet – Inspect float tank mounting to insure that the center tube at the bottom of the float tank is level to 1/8" above the lower steel overflow tube found on the back of the toilet bowl on the left hand side. To adjust, loosen the two 1/4-20 hex nuts on the float tank slotted mounting bracket and raise or lower float tank assembly as required to bring into adjustment. Tighten the two hex nuts securely.*
- 2) Too low water delivery pressure to the unit - The system is designed to operate above 35 PSI inlet pressure to insure proper vacuum supply to the overflow prevention system. Correct as required*

Troubleshooting Guide Diagram

If toilet will not flush, but there is no overflow condition present...

Make sure no portion of 1/4" O.D. natural LDPE tubing is below the water level sensor. If tubing is found to be installed below water level sensor, and flush valve will not activate, push the flush valve pushbutton 2-3 flush cycles to allow any excess water to drain back from the valve through the tubing into the toilet bowl. If water remains in tubing then disconnect tubing from the back of the fixture at water level sensor and manually drain. Reinstall tubing ensuring no loops so that no portion of the tubing is below water level sensor. Unit will then function as designed.

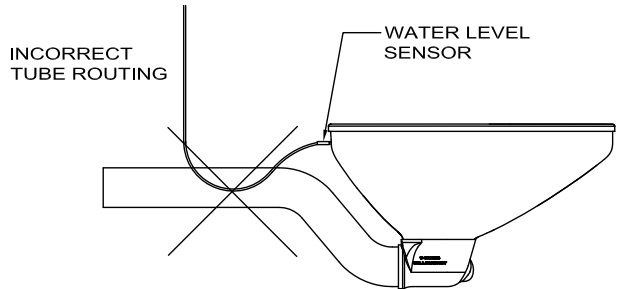
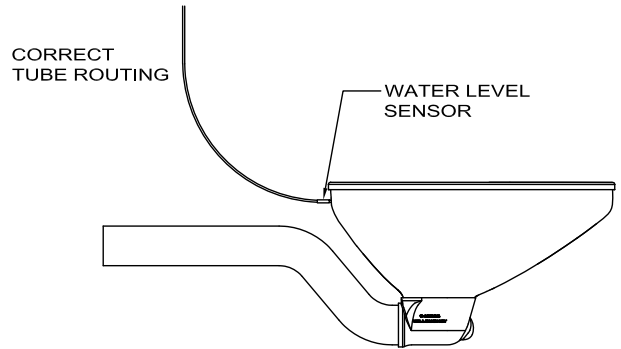
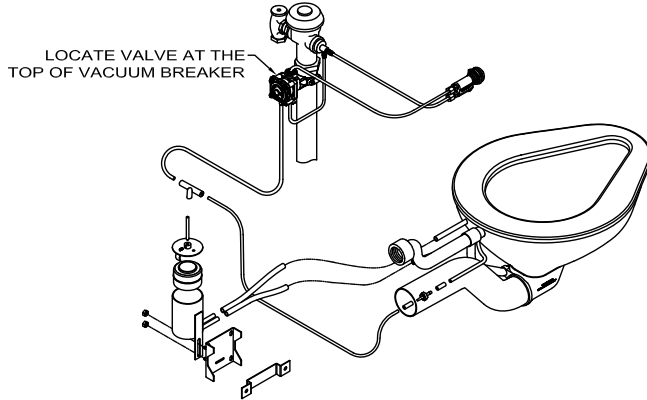

Warranty

Willoughby Industries, Inc. warrants to commercial and institutional purchasers only that each unit will be free from defects in workmanship and materials under normal use and service upon the following terms and conditions. The period during which components are warranted is as follows:

1. All other components warranted for 1 year from date of shipment.

This warranty does not cover installation or any other labor charges and does not apply to any components damaged by accident, abuse, improper installation or improper maintenance. This warranty does not cover any installation that did not comply with national, state and local building, plumbing or electrical codes. The warranty is limited to replacing or repairing at manufacturer's option, transportation charges prepaid by the purchaser, any component or part which upon our inspection shall be deemed as defective within the limitations of this warranty. The replacement or repair of defective units as stated in this warranty shall constitute the sole remedy of the purchaser and the sole liability of Willoughby Industries, Inc. Willoughby Industries, Inc. shall not otherwise be liable under any indirect damages caused by defects in the repair or replacement thereof.

This warranty only extends to commercial and industrial purchasers and does not extend to any others, including consumer customers of commercial institutional purchasers. This warranty is in lieu of all other warranties, expressed or implied, including implied warranty of merchantability or fitness for a particular purpose or otherwise.