

Installation & Operation Manual

WAF-2200 Series

AquaFount-90® Corner Mounted Washfountain Electronic/Pneumatic

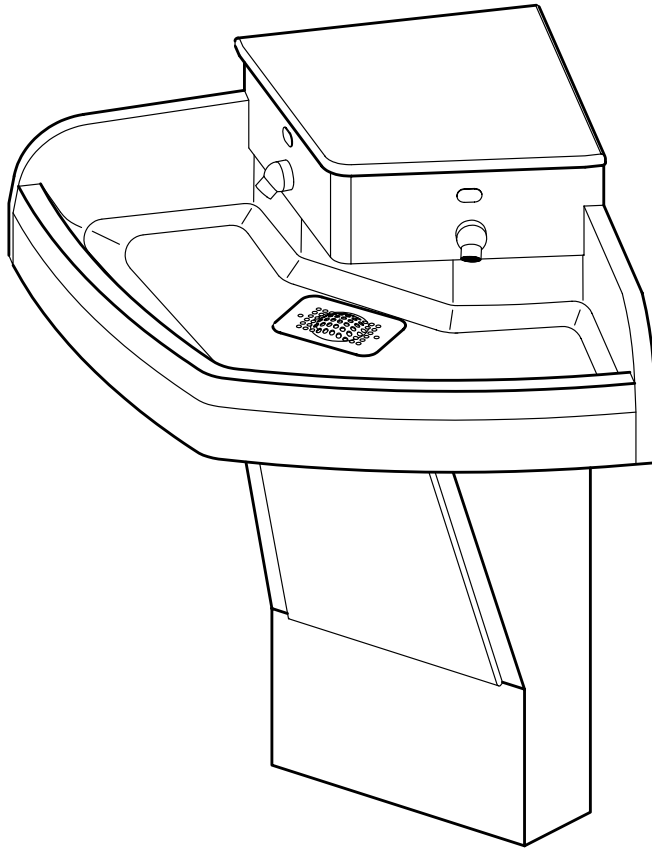

WAF-2200

Table of Contents

Pre-Installation Information.....	3
Physical Dimensions	4
Rough-In Dimensions	6
Required Installation Supplies	9
Parts List	10
Exploded-view Drawing.....	11
Hardware Identification	12
Installation Instructions	
Step 1: Pedestal Mounting.....	13
Step 2: Drain Assembly	14
Step 3: Head and Basin Assembly	15
Step 4A: Connections for Infrared/Piezo Actuators.....	16
Step 4B: Connections for Pneumatic Actuators	17
*Step 4A and 4B Detail Drawings	18
Step 5: Final Assembly	19
JACO Fitting Instruction.....	20
Adjustable Mixing Valve Installation	21
Infrared Sensor Installation Instructions	22
Pneumatic Valve Operation Details	23
Liquid Soap Specification and Maintenance.....	24
Care and Maintenance	25
Troubleshooting	
Infrared Sensors	26
Electronic Valves	27
Pneumatic Valves	28
Drawings.....	
General Dimensions and Rough-in Detail	30
Valve Details	32
Miscellaneous Details.....	38
Warranty.....	42



Willoughby Industries, Inc.

5105 West 78th Street
Indianapolis, IN 46268
Toll Free: (800) 428-4065
Local: (317) 875-0830
Fax: (317) 875-0837
www.willoughby-ind.com

WILLOUGHBY

Rev. 8/2023

MADE IN THE U.S.A.



(Page intentionally left blank)

Pre-Installation Information

Installation notice!

Check Rough-In location **PRIOR** to installation

Flush lines thoroughly **PRIOR** to hook-up

When installing the **Willoughby Industries' WAF-2200 Series** washfountain:

Before Step 1 of the installation instructions, ensure that rough-ins are in the correct location.

The valve assembly, including the spray head, **MUST NOT BE** connected until *after* all lines have been flushed to remove the small particles of debris that are inherent with new construction projects and all chemicals that are used in flushing are purged from the system.

Chemicals used in flushing plumbing systems can attack the internal components of the valve and spray head and severely damage them, so any flushing of the system must be followed by a full flushing with pure water to clear any harsh chemicals remaining in the system. Debris in the system if allowed to enter the valve assembly and spray head can cause poor performance or outright failure.

Again **DO NOT** attempt to connect the valve assembly and spray head until *after* all flushing is complete and pure water is the only media that will be passing through the system. Damage to the valve assembly or spray head caused by harsh chemicals or debris will not be covered by the manufacturer's warranty.

Installation notice!

Check Rough-In location **PRIOR** to installation

Flush lines thoroughly **PRIOR** to hook-up

Physical Dimensions- WAF-2200

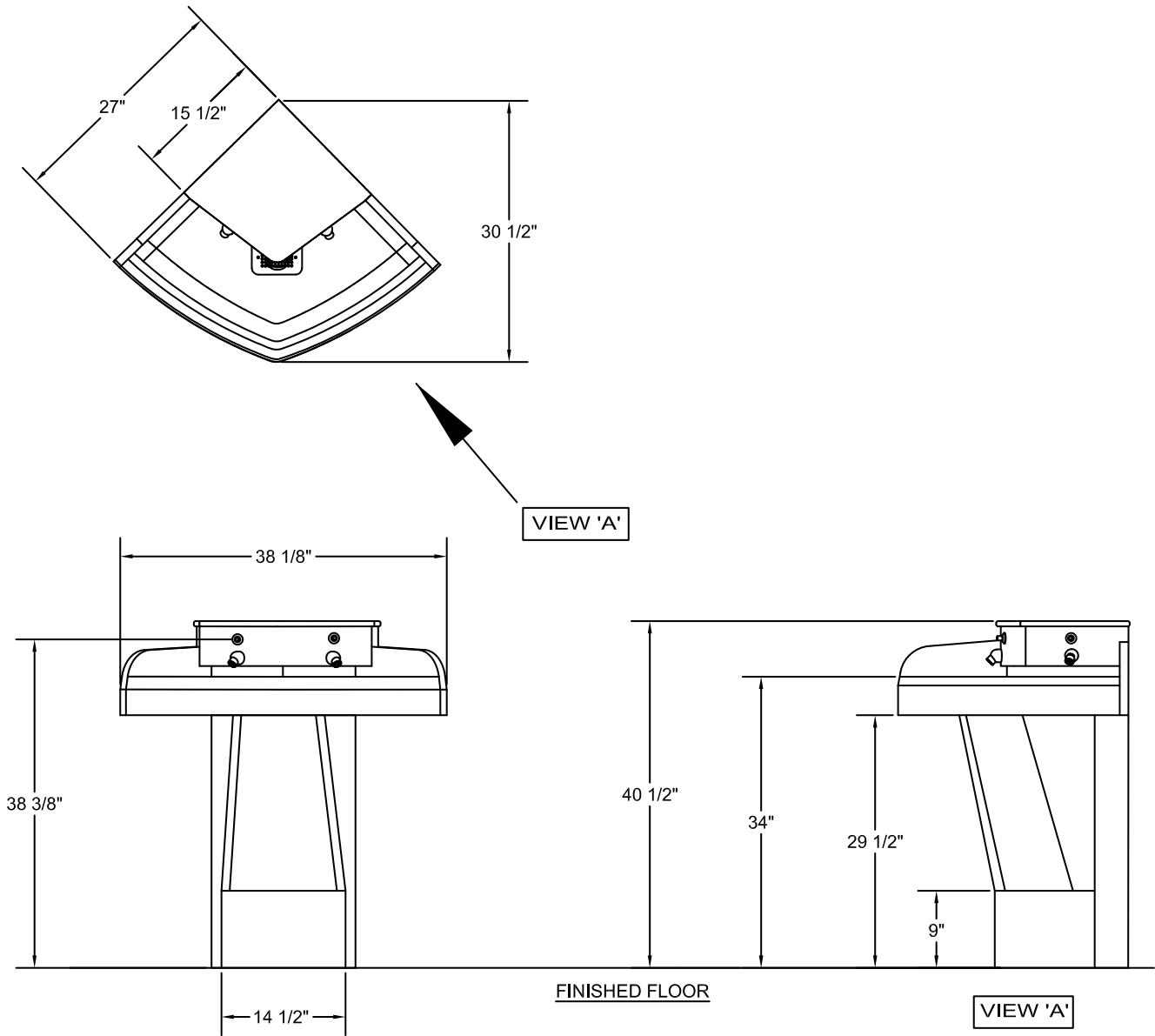

Physical Dimensions- WAF-2201

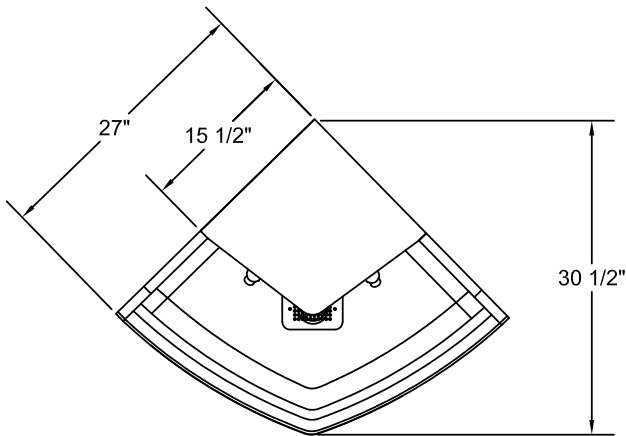

VIEW 'A'

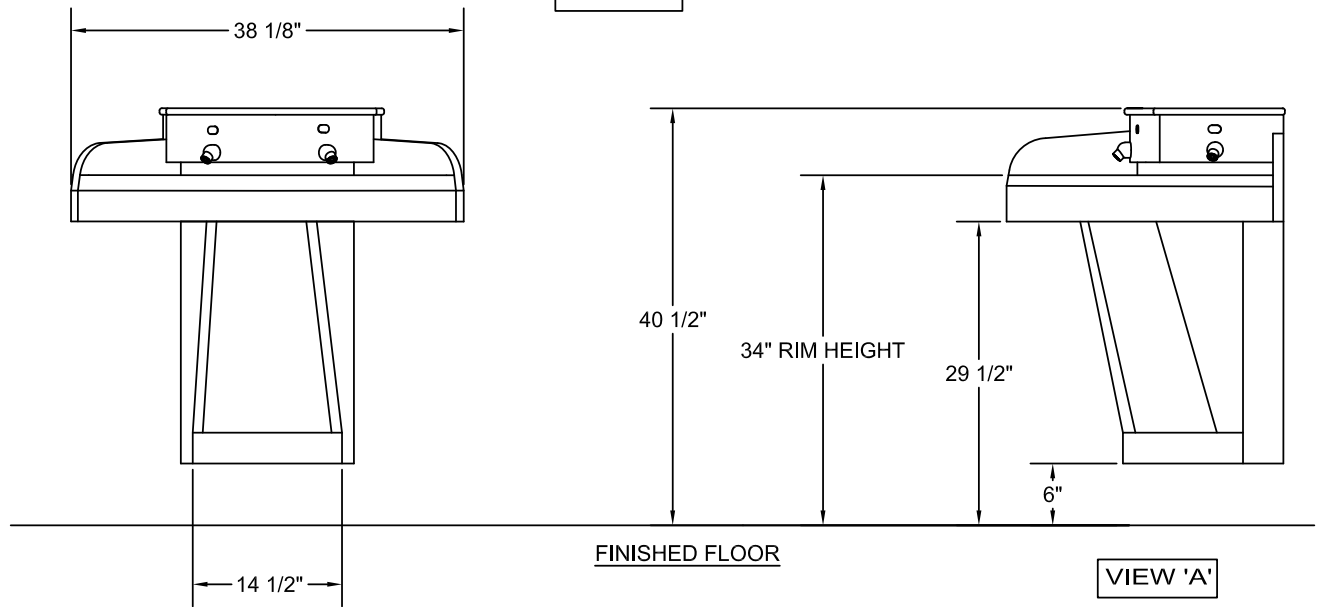

Rough-In Dimensions- WAF-2200

Plumbing Rough-Ins (floor-mounted WAF-2200)

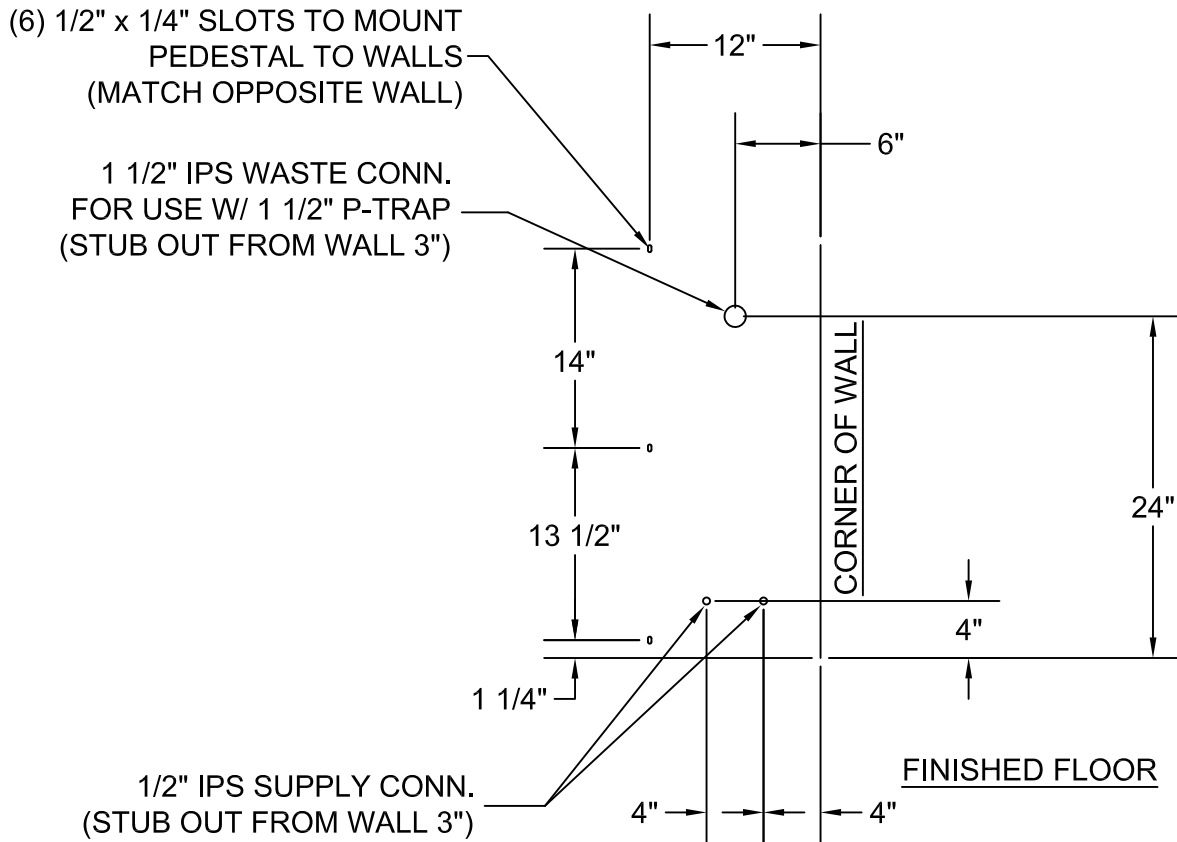

Rough-In Dimensions- WAF-2201

Plumbing Rough-Ins (wall-mounted WAF-2201)

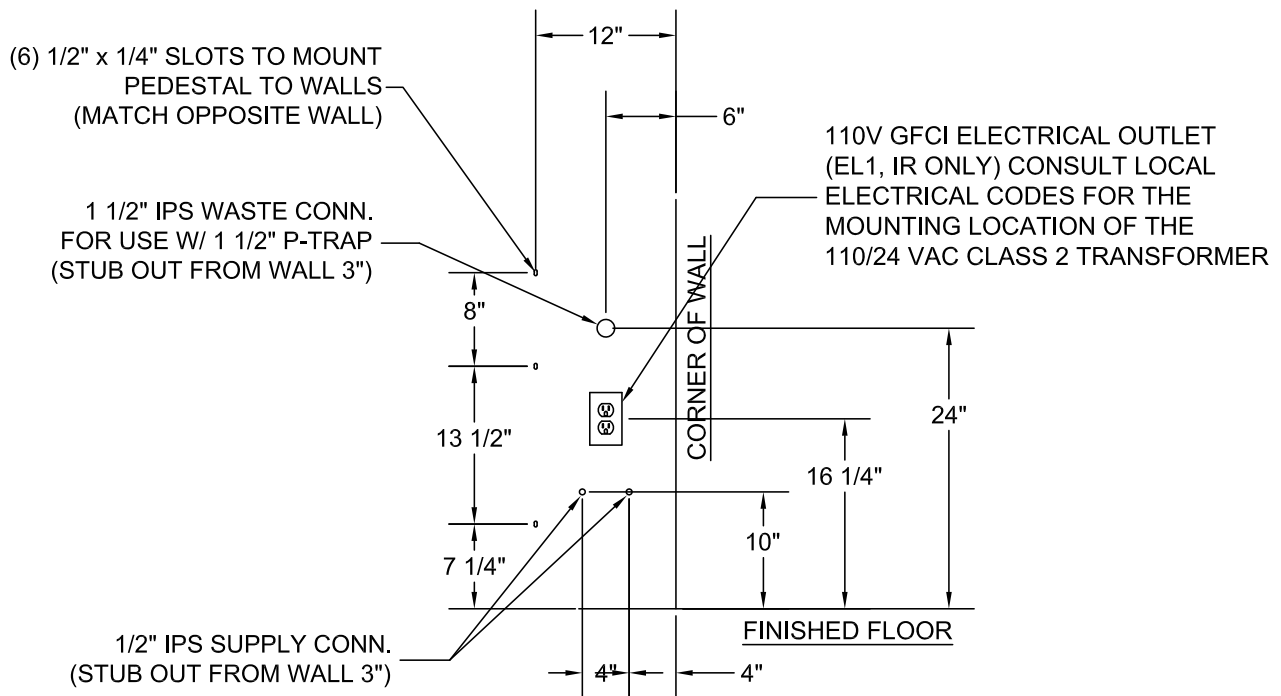

(Page intentionally left blank)

Required Installation Supplies

- Proper mounting hardware
- Hardware for waste outlet connections
- Gasket for waste outlet connection
- Shims (for installation if necessary)
- Supply piping
- Silicone caulk

□ WARNING: Willoughby Industries does not assume any responsibility for personal injury or damage to equipment due to an improperly installed WAF-2200 Series washfountain.

Parts List

ITEM	DESCRIPTION	PART#
1	SOLID SURFACE BASIN	802202C-XX*
2	SOLID SURFACE TOP COVER	802203C-XX*
3	FRONT PANEL	800334C-XX*
4	DRAIN ASSEMBLY	800043B
5	PIEZO ACTUATOR HOUSING ASSEMBLY	802106-2E
	INFRARED ACTUATOR HOUSING ASSEMBLY	802106-2I
	PNEUMATIC ACTUATOR HOUSING ASSEMBLY	802106-2P
	BATTERY OPERATED INFRARED ACTUATOR HOUSING ASSEMBLY	802106-2B
6	ELECTRONIC VALVE ASSEMBLY	803105-2EW
	PNEUMATIC VALVE ASSEMBLY	803105-2PW
	BATTERY OPERATED VALVE ASSEMBLY	803105-2BW
7	PEDESTAL (STANDARD)	802200-2FL
-	POWER SUPPLY	700156-2
	HARDWARE KIT	801125
	STND. SPRAY HEAD ASSEMBLY- WAF (AERATOR SPRAY HEAD, 0.5 GPM- #320157A) (SPRAY HEAD BASE, 45*- #800001)	320157A-ASMB

*XX REPRESENTS THE WASH FOUNTAIN COLOR

WHITE GRANITE=WG
 SAND STONE=SS
 GRAY GRANITE=GG
 BLACK GRANITE=BG
 SEA GREEN=SG
 NOCTURNAL BLUE=NB
 RED CORAL=RC
 GLACIER WHITE=GW
 BONE=B

Exploded-view Drawing

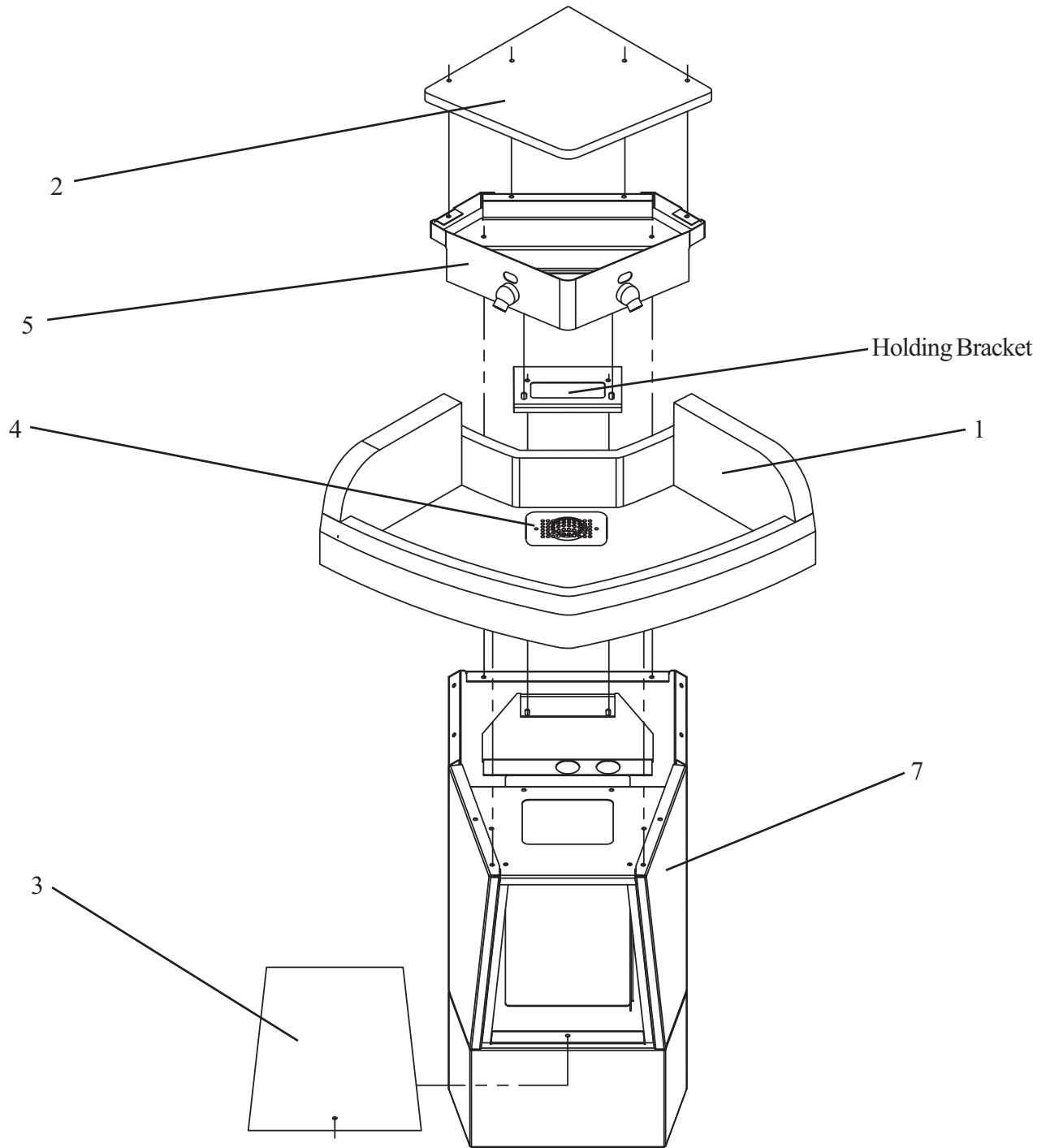

Hardware Identification

P/N 801125 Hardware Kit

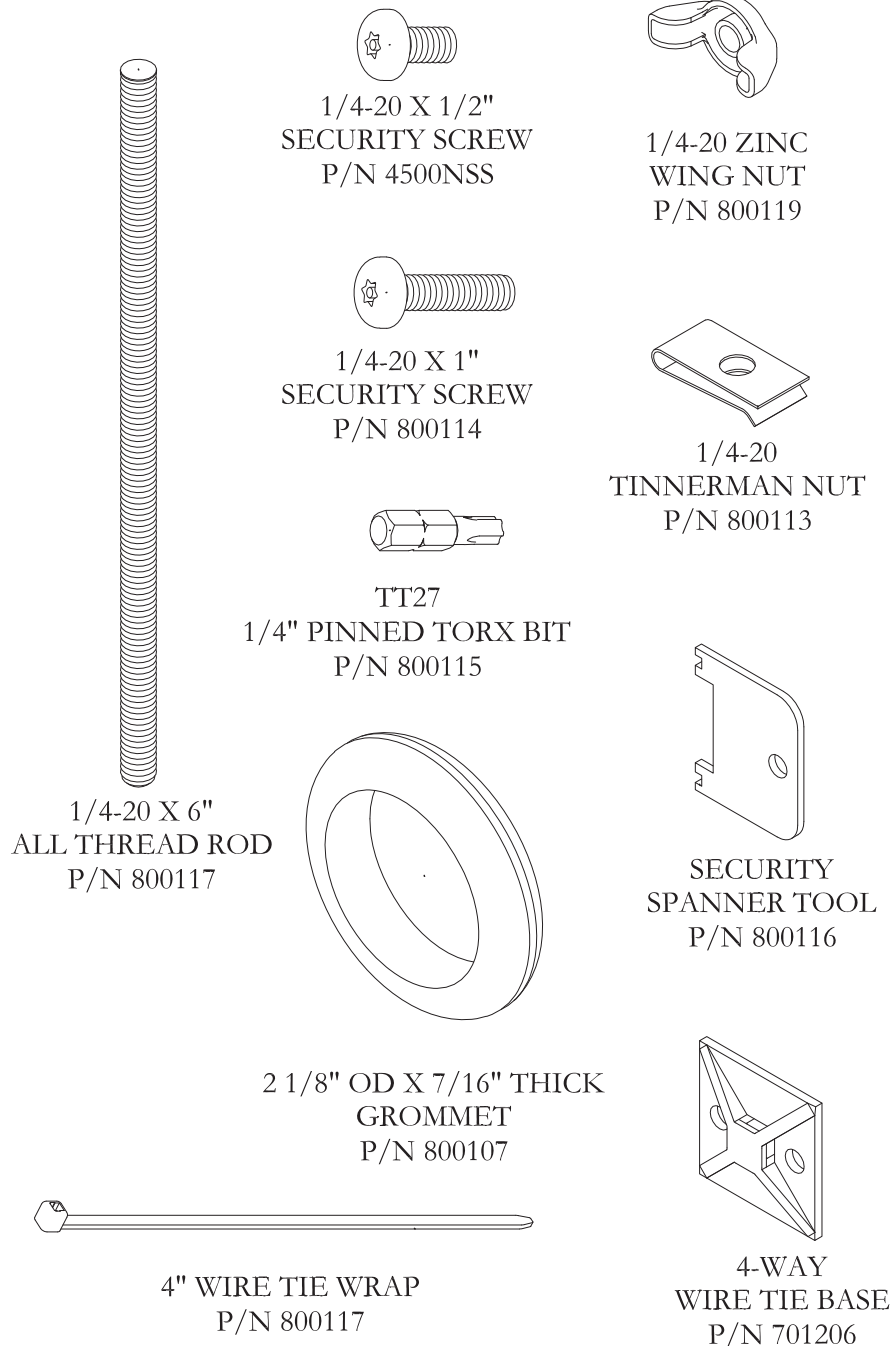

Installation Instructions

Step 1: Pedestal Mounting

Parts supplied:

- Pedestal (pre-assembled)

Note: Hardware for wall anchoring by others

- 1.) Remove plastic protective coating from all stainless parts before installation.
- 2.) Place pedestal in corner and mark mounting points (3 slots per side).

Note: Be sure back panel is level and plumb against wall so that water in basin will drain correctly once assembly is completed.

- 3.) Drill holes in the wall for anchors. Make sure that the intended anchor locations will provide adequate backing to support the installed washfountain. If adequate backing does not exist, install appropriate support backing or relocate unit before proceeding with installation (backing provided by others).
- 4.) Secure the pedestal to the wall using wall anchors that are adequate for the type of wall: dry wall, concrete, metal studs, wood studs, etc. (supplied by others).

Installation Instructions (cont.)

Step 2: Drain Assembly

Parts/Materials supplied:

- Solid surface basin
 - Drain assembly
- 1.) Insert drain spud into wash basin using silicone caulk (supplied by others).
 - 2.) From beneath basin, thread the washer & locknut onto the drain spud and secure locknut against wash basin.
 - 3.) Secure drain cover using the provided security screws.

Note: Over-tightening the locknut or security screws can damage the solid surface basin and/or drain assembly components.

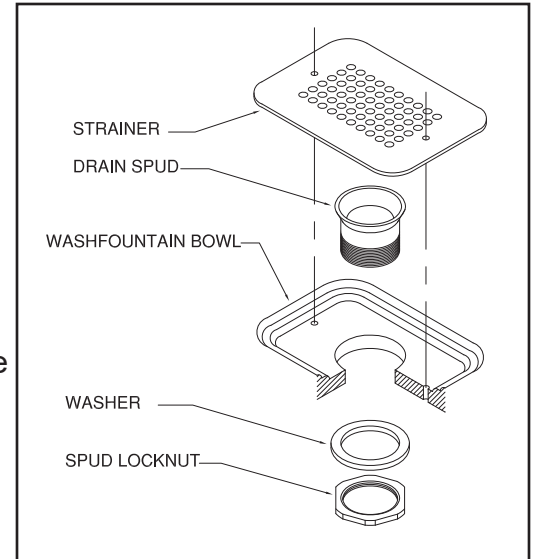

Installation Instructions (cont.)

Step 3: Head and Basin Assembly

Parts supplied:

- Solid surface wash basin
- Pedestal base assembly
- Actuator housing assembly

Caution: Do not leave bowl on the pedestal unsupported, as it may fall and cause damage or personal injury.

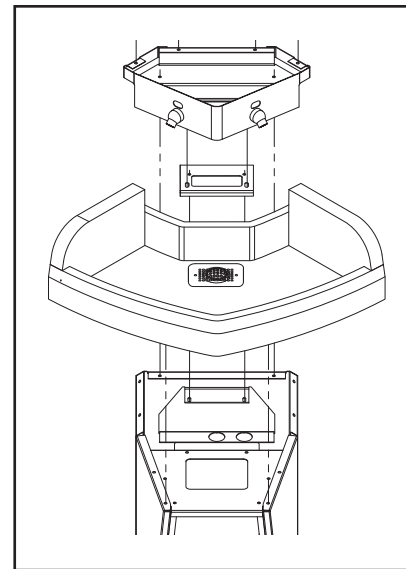

- 1.) With the help of an assistant, carefully lift wash basin onto pedestal base. Line up the 2 front brass threaded inserts on the basin with the 2 holes on the forward top of the pedestal, secure with 4 security screws. **Do not fully tighten screws yet.**

Note: BE SURE to use the security screws included with the washfountain. Using longer security screws than those provided can damage the solid surface basin.

- 2.) "Sandwich" the basin between the pedestal top and the holding bracket using tinnerman nuts and security screws.
- 3.) Tighten the screws from step 1.).
- 4.) Place the Actuator Housing Assembly on top of the basin; position it so the 2 holes near the back of the actuator housing assembly line up with the holes of the basin bracket. Using 1/4-20 x 1/2" security screws secure in place. **Do not fully tighten screws yet.**
- 5.) Thread one wing nut on top of each all-thread rod just until the threads come through the other side; turn over so that the nut is now on the bottom. Holding the end with the wing nut with your hand, slide the all-thread rod through the slot in the actuator housing from the bottom side. Secure in place with a second wing nut. Repeat the process for the other hole.
- 6.) Attach additional wall anchors (if needed) through the Actuator Housing into the wall.
- 7.) Tighten all screws from previous steps and the wash basin is ready for plumbing and/or electrical installation*.

***If you have infrared sensors or electrical pushbuttons, go to Step 4A.
If you have pneumatic pushbuttons, go to Step 4B.**

Installation Instructions (cont.)

Step 4A: Connections for Infrared/Piezo Actuators*

Parts supplied:

- Valve Assembly (pre-installed)
- 3/8" x 4' Multi-Colored Water Lines
- Small Diameter Multi-Colored Pneumatic Tubing
- 1/4-20 x 1/2" security screws
- 1/4-20 tinnerman nuts

***For detail drawings on
Step 4A instructions,
see Page 18**

Note: Use wire tie mounts and wire ties to route and secure wiring. Wires are long enough to accommodate various routing paths. Longer tubes may need to be bundled with wire ties so they do not come in contact with sharp corners.

- 1.) Locate the terminal block plate and attach to the pedestal using 1/4-20 x 1/2" security screws and tinnerman nuts.
- 2.) Locate the group of loose colored wires coming from the terminal block plate labeled "UPPER".
- 3.) Feed 2 like-colored wires into each of the actuator housing assemblies (either the Infrared or Piezo assemblies, whichever applies to the installation).
- 4.) Plug both like-colored wires into the actuator as shown above (either wire will work on each connector).
- 5.) Locate the 3/8" multi-colored water lines. Match the color of each water line with the corresponding color of wiring. Run the end of each water line up through the basin to the head kit. Match the color of each water line to the spray head assembly below each actuator. On each corresponding spray head, loosen the plastic nut on the plastic connector and firmly push the water line through the plastic nut into the fitting. Tighten the plastic nut to secure the water line to the spray head. Repeat for each remaining water line. (**see JACO Fitting Instructions on Page 20 for further detail).
- 6.) Once all water lines have been attached to their corresponding spray heads, on each corresponding manifolded valve assembly, loosen the plastic nut on the plastic connector and firmly push the water line through the plastic nut into the fitting. Tighten plastic nut to secure the water line to the valve assembly. Repeat for each water line.
- 7.) Connect each set of like-colored wires to each of the manifolded valves.

Installation Instructions (cont.)

Step 4B: Connections for Pneumatic Actuators*

Parts supplied:

- Valve Assembly (pre-installed)
- 3/8" x 4' Multi-Colored Water Lines
- Small Diameter Multi-Colored Pneumatic Tubing
- 1/4-20 x 1/2" security screws
- 1/4-20 tinnerman nuts

*For detail drawings on
Step 4B instructions,
see Page 18

Note: Use wire tie mounts and wire ties to route and secure tubing. Longer tubes may need to be bundled with wire ties so that do not come in contact with sharp corners.

- 1.) Locate the small multi-colored pneumatic tubing. Feed each one into each of the actuator housing assemblies.
- 2.) Plug each tube onto the hose barb on the back of the push button.
- 3.) Locate the 3/8" multi-colored water lines. Match the color of each water line with the corresponding color of tubing. Run the end of each water line up through the basin to the head kit. Match the color of each water line to the spray head assembly below each push button actuator. On each corresponding spray head, loosen the plastic nut on the plastic connector and firmly push the water line through the plastic nut into the fitting. Tighten the plastic nut to secure the water line to the spray head. Repeat for each remaining water line. (**see JACO Fitting Instructions on Page 20 for further detail).
- 4.) Once all water lines have been attached to their corresponding spray heads, on each corresponding manifolded valve assembly, loosen the plastic nut on the plastic connector and firmly push the water line through the plastic nut into the fitting. Tighten plastic nut to secure the water line to the valve assembly. Repeat for each water line.
- 5.) Connect each set of like-colored tubing to each of manifolded valves.

Installation Instructions (cont.)

*Step 4A and 4B Detail Drawings

Step 4A: Infrared and Piezo (Electronic)

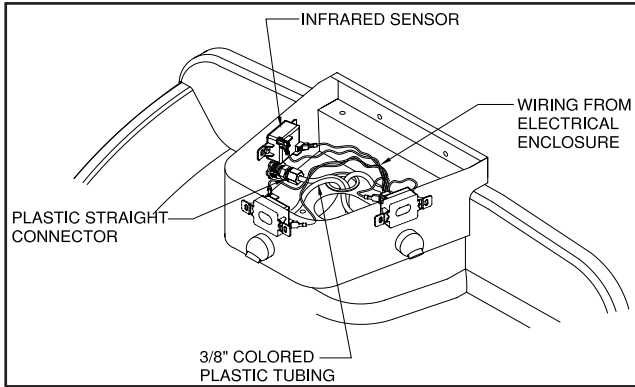

Infrared Sensor (3-station unit shown)

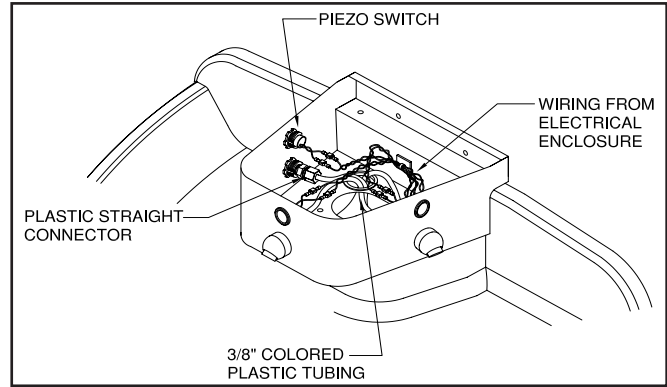

Piezo Push Button (3-station unit shown)

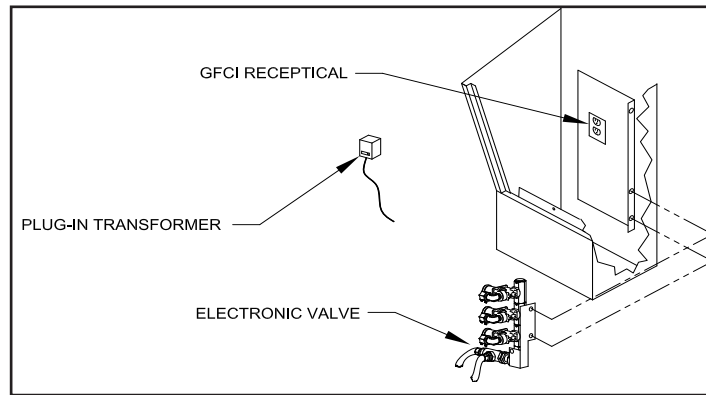

Plug-in Transformer detail

Step 4B: Pneumatic

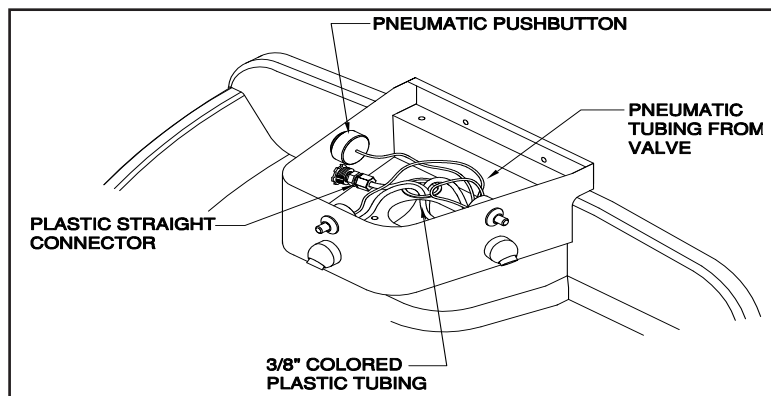

Pneumatic Push Button (3-station unit shown)

Installation Instructions (cont.)

Step 5: Final Assembly

Parts supplied:

- Solid surface cover
- Front panel
- 1/4-20 tinnerman nut
- 1/4-20 x 1" security screws
- 1/4-20 1" flat head security screws.

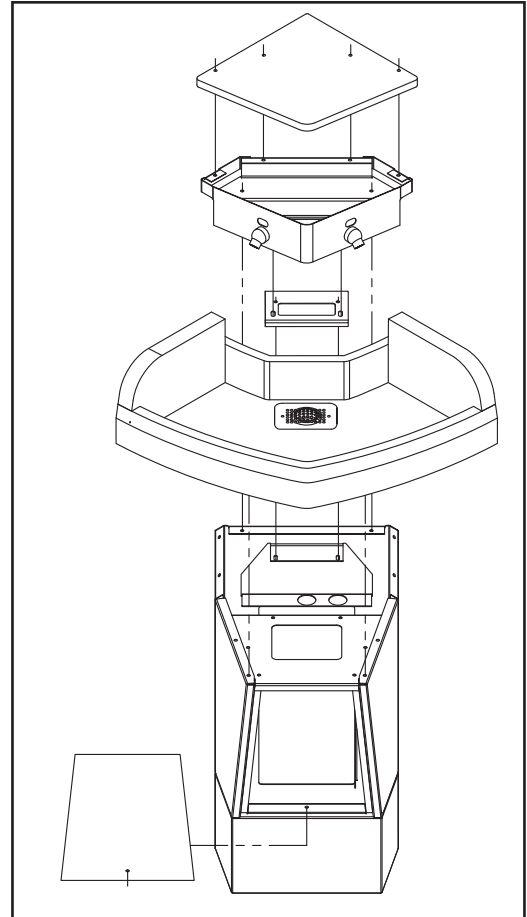

- 1.) Make all final plumbing connections to valve inlets using supplied flex hoses (flex hoses have shut-off valves attached that should be connected to the supply inlets).
- 2.) Once all of the connections in the actuator housings are complete, locate the transformer.

NOTE: PLUG-IN TRANSFORMER (IF NEEDED) MUST BE USED WITH A GROUND FAULT INTERRUPT (GFCI) RECEPTACLE TO HELP PREVENT POSSIBLE ELECTRICAL SHOCK.

- 4.) Test the system for leaks (both supply and waste).
- 5.) Slide 1/4-20 tinnerman nuts over tab with holes on the actuator housing.
- 6.) Using 1/4-20 x 1" flat head security screws, attach top cover to the actuator housing.
- 7.) Using 1/4-20 x 1" security screws, attach front panel to the pedestal.

JACO Fitting Instruction



Note: It is not necessary to disassemble this fitting for application. Merely insert tubing to stop and tighten seal.

1. Cut tubing end squarely and remove the internal burrs.
2. Insert the tubing through the back of the nut all the way through the nut assembly to the tube stop in the fitting body (see illustration). If the tubing does not enter the nut easily, loosen the nut one turn and reinsert the tubing all the way to the tube stop in the fitting body.
3. Turn the nut hand tight.
4. Wrench tighten the nut $1\frac{1}{2}$ - 2 turns.
5. All nuts must be retightened when the system reaches projected operating temperature.

Note: To ensure proper assembly, tubing MUST be fully inserted into the fitting body all the way to the tube stop.

Note: Squeaking sound when tightening nut is normal. For pipe threaded connections, Teflon tape must be used.

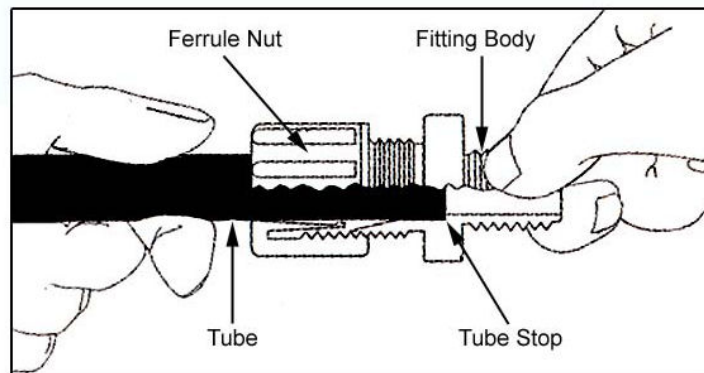
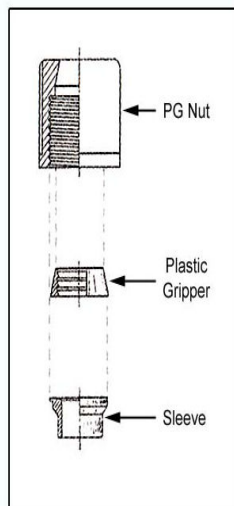

Adjustable Mixing Valve Installation

POWERS™

IS-P-e480

**HydroGuard® T/P Series e480
Lavatory Combination Valve**

Installation Instructions

To Install ■

NOTE: Installation should be in accordance with accepted plumbing practices. Flush all piping thoroughly before installation.

1. Locate a suitable place for the tempering valve. Valve should be accessible for service and adjustment and as close to the point-of-use as possible.
2. Connect hot and cold water to the supply valve using 1/2" NPT or 3/8" compression connections.
3. Connect outlet of tempering valve to fixture(s) using 1/2" NPT or 3/8" compression connections.
4. Turn on hot and cold water supplies. If any leaks are observed, tighten connections as necessary to stop leaks before proceeding.
5. Turn on fixture and allow water to flow for 2 minutes. Measure water temperature at outlet. If water is not at desired temperature, adjust as necessary.

Specifications ■

e480-00	1/2" NPT (Rough Bronze)
e480-01	1/2" NPT (Rough Chrome)
e480-10	3/8" Compression (Rough Bronze)
e480-11	3/8" Compression (Rough Chrome)
Capacity:	4.0 gpm (15.0 l/m)
Approach Temperature:	5°F (2.8°C) above set pt.
Max. Operating Pressure:	125psi (862 kpa)
Max. Static Pressure:	125psi (862 kpa)
Max. Hot Water Temperature:	180°F (82°C)
Temp. Adjustment Range:	
..... ASSE Type T/P:	95 – 110°F (43-48°C)
..... ASSE Type T:	80 – 120°F (27-49°C)
Minimum Flow:	0.5 gpm (2.2 l/m)
Checks:	Integral
Construction:	Cast Brass Body
Certified:	CSA B125
Listing	ASSE 1016-1996 (Type T/P)
.....	ASSE 1070

CALIFORNIA PROPOSITION 65 WARNING

WARNING: This product contains chemicals known to the State of California to cause cancer and birth defects or other reproductive harm. (California law requires this warning to be given to customers in the State of California.)
For more information: www.watts.com/prop65

Figure 1

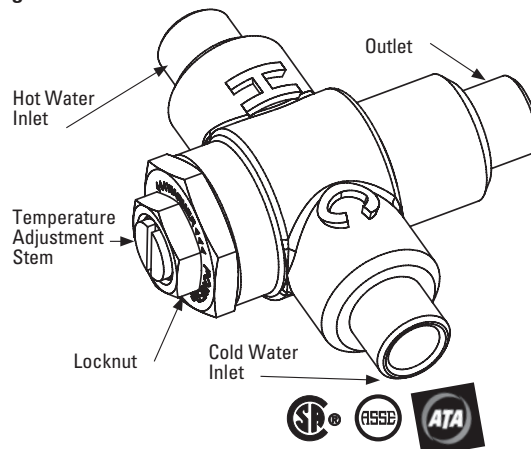
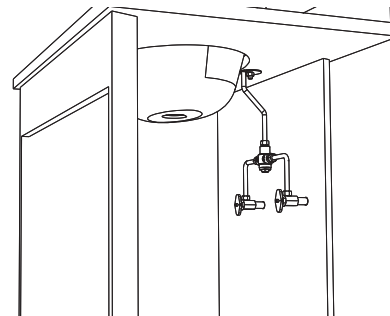

Figure 2: Typical Installation



To Adjust Temperature ■

1. Loosen locknut.
2. Turn on fixture and run water for at least two (2) minutes to allow supply temperature to stabilize.
3. Turn temperature stem counter-clockwise for hotter or clockwise for colder outlet temperature.
4. Tighten locknut to prevent accidental or unauthorized temperature adjustment.
5. Re-check outlet temperature.

Repair Kit ■

Motor Repair Kit..... 480-270

Infrared Sensor Installation Instructions

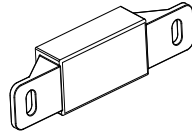

Willoughby Industries Infrared Lavatory Sensor Installation Instructions

DETECTION AND ACTIVATION

When the sensor detects a user, a slow flashing red light appears in the sensor window. After 1 to 2 seconds of detection, the light flashes rapidly and the sensor immediately activates the solenoid valve to begin water flow. The solenoid valve remains open as long as the user is detected. The solenoid valve turns off when the user is no longer detected. The sensor is set to activate the solenoid for a maximum of 30 seconds before automatically shutting off.

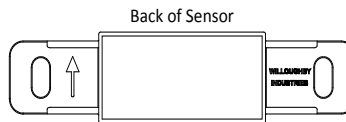

Figure 1

INSTALLATION AND REPLACEMENT

1. Disconnect 24Vac power at the transformer or fuse box.
2. Remove top cover to expose sensors.
3. Install new sensor. Make sure sensor arrow is pointing up. See figure 1.
4. Connect the red male power cable to the red female connector on the sensor. See figure 2.
5. Connect the black female solenoid cable to the black male connector on the sensor. See figure 2.
6. Replace top cover removed in step 2.
7. Reconnect power.

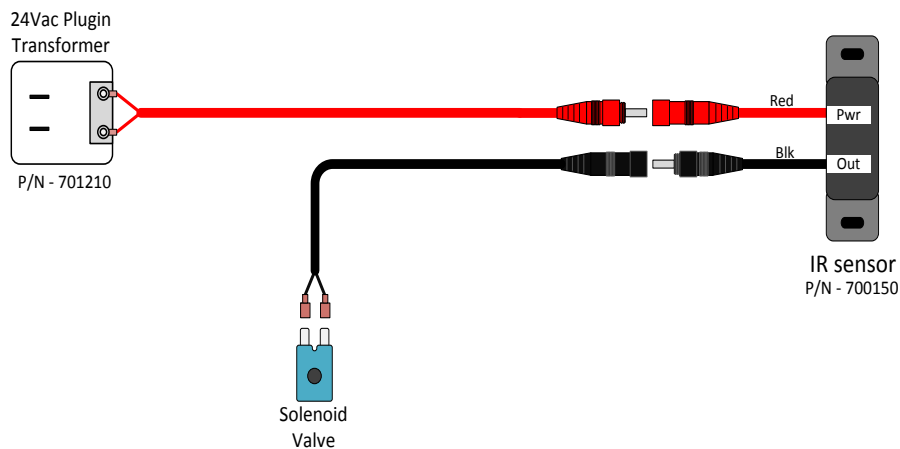
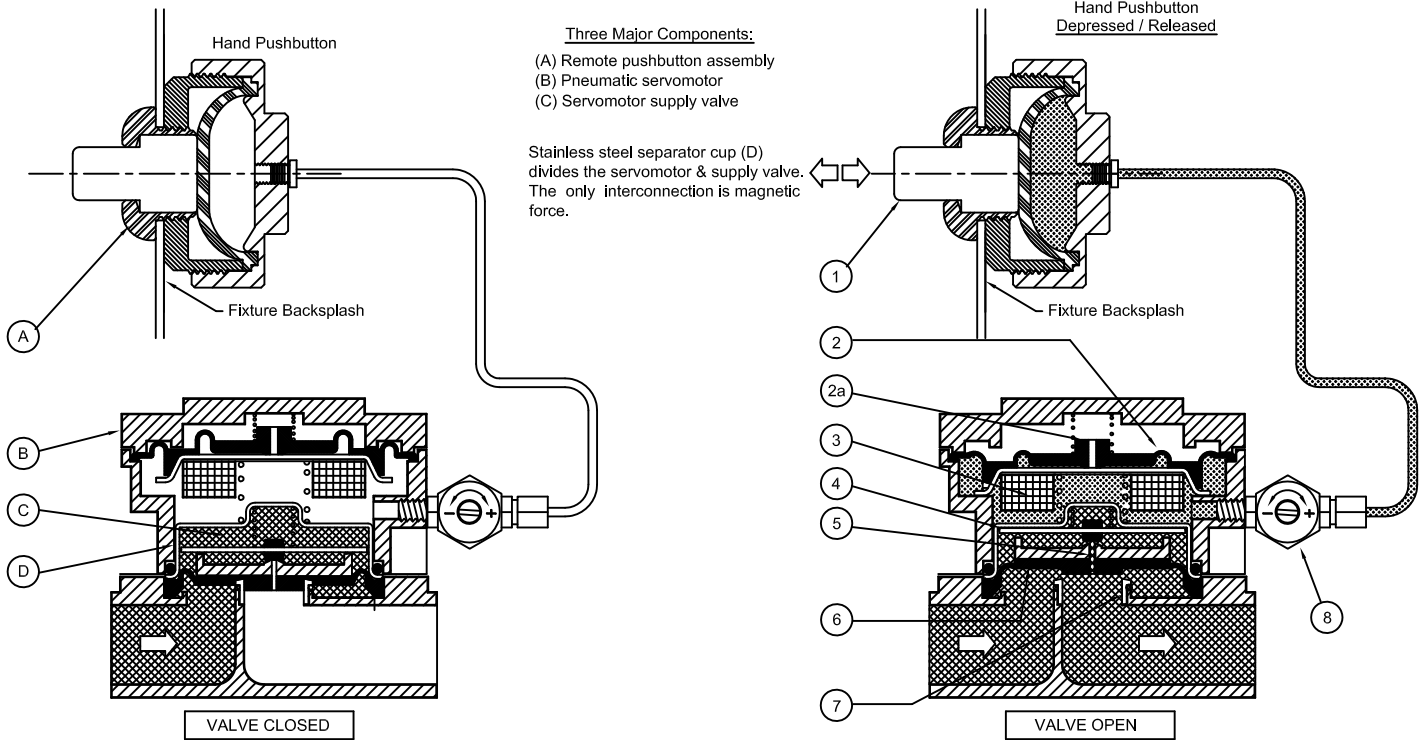

Figure 2

Pneumatic Valve Operation Details



Valve Closes: Air bleeds in through the timer (8) into the chamber below the actuating diaphragm (2). When the pressure in this chamber returns to normal, the diaphragm (2), and the magnet (3), are forced up. The pilot orifice plate (4) drops, covering the pilot orifice (5). Water pressure increases above the seat diaphragm (6), closing the diaphragm (6), against the seat (7).

Valve Opens: Depressing the button (1), forces air through the actuating diaphragm check valve (2a), and to atmosphere. Releasing the button (1), creates a vacuum below actuating diaphragm (2), and magnet (3). Diaphragm (2), and magnet (3), are forced down. Pilot orifice plate (4) is pulled up by magnet (3), opening the pilot orifice (5), bleeding off line pressure from above the seat diaphragm (6). Water pressure then lifts the seat diaphragm (6), off the seat (7), and opens the valve.

Liquid Soap Specification and Maintenance

(For models with “LSD” option only)

Liquid soap viscosity is measured in “cps” (centipoise). The liquid soap chosen to be used with Willoughby’s Liquid Soap Dispenser should be between 100cp and 2500cp.

The viscosity of the soap should be thin and free flowing.

Some soap types are available in a concentrate and must be diluted with water.

The pH (acidity) level should be in the range of 6.5 to 8.5.

Soap which is too acidic (pH less than 6.5) can corrode stainless steel and degrade rubber, plastic, or chrome-plated materials.

Soap that is outside the range of 6.5 - 8.5 might be harsh on the hands or skin.

(Generally, any quality soap meeting the viscosity and pH guidelines should work well.)

Recommended Maintenance Schedule

To maintain proper function, Willoughby’s Liquid Soap Dispenser should be cleaned periodically to remove soap residue. The Liquid Soap Spout should be soaked in hot water for a period of 30 minutes when cleaning is being performed. The soap tray should also be cleaned with hot water.

Care and Maintenance

Solid Surface Care

Surfaces may be easily cleaned using conventional cleaning agents such as an ammonia based liquid cleaner, (glass cleaner).

Dry stains on a matte finish can be removed with a 3M Scotch-Brite gray scouring pad or a mild abrasive cleaner.

Burns or scorches can be removed by sanding with coarse grit sandpaper followed by finer grit (220) sandpaper. Follow sanding with a 3M Scotch-Brite gray pad (or equivalent) to match finish of sanding area to surrounding area. A final buffing may be required on polished surfaces. Accidental nicks or chips can be repaired with special patch kits available in all colors.

Avoid exposing surfaces to strong chemicals such as acetone's; paint removers and sulfuric acid or hydrochloric chemical cleaners. Exposure to strong chemicals may result in permanent damage to surfaces.

Stainless Steel Care

Stainless Steels are basically alloys of iron and chromium and are corrosion resistant. Stainless steel has a bright surface that is easy to clean and is free from oxides. Therefore, cleaning of stainless steel is relatively simple and easy if done on a regular basis.

Frequency of cleaning should depend on the rate at which the fixture becomes dirty. Remember that fresh (soft) deposits of all kinds are relatively easy to remove, while removing older (hard) deposits are much more difficult. Establish a cleaning SCHEDULE.

Routine cleaning should involve ordinary soap or detergent and water, applied with a sponge, brush or cloth. Baking soda, borax or any of several non-abrasive commercial cleansing agents can help hasten the cleaning action. after scrubbing, rinse THOROUGHLY and wipe dry.

DO NOT use common steel wool, scouring pads, scrapers, wire brushes, files or other steel tools to clean stainless steel. Such items will scratch the surface or leave small particles of iron imbedded in the surface, which will eventually rust and stain the surface - even appearing as if the stainless itself was rusting.

Certain chemical compounds, if used on stainless steel, can give the appearance of rust and if allowed to stand for long periods of time, can pit the surface of stainless steel. Products containing hydrochloric acid, muriatic acid or potassium hydrochloride can ruin the surface.

Troubleshooting - Infrared Sensors

- I. Faucet does not function (red light does not appear when user steps in front of sensor)
 - A. No power to sensor. Make certain that power is on. Check transformer leads and connections. Repair or replace as necessary.
 - B. Willoughby 700150 IR Sensor not operating. Replace Willoughby 700150 IR Sensor.

- II. Faucet does not function (red light appears when user steps in front of sensor and solenoid does not click)
 - A. Debris in solenoid; disassemble, clean, and flush.
 - B. Solenoid not wired correctly; check solenoid connections.
 - C. Solenoid problem; replace solenoid.

- III. No water when activated (valve clicks)
 - A. Make certain that water is turned on.
 - B. Valve clogged. Clean or replace filter.

- IV. Very low flow or slow dribble
 - A. Check supply stop(s); open if closed.
 - B. Debris in filter; remove, clean, and reinstall.
 - C. Debris in aerator or spray head; remove, clean and reinstall.
 - D. Disassemble solenoid; clean and flush.

- V. Continues to run (with power on and red light flashing)
 - A. Non-permanent target in range after user leaves. Remove non-permanent target. If this target is a new permanent target (i.e., a new wall or partition), turn off 24 volt power for fifteen (15) seconds. Turn power back on and let the sensor complete start-up mode.
 - B. Sensor failure; replace sensor.

- VI. Continues to run (even with power disconnected)
 - A. Solenoid valve installed backwards.
 - B. Debris in solenoid, won't close properly; remove operator and clean. Reassemble in the same manner.

Troubleshooting - Electronic Valves

The two most common reasons an electronic valve does not operate properly are: (1) lack of power or (2) lack of water pressure. The following steps should be used as a guide in identifying the problem of a malfunctioning electronic valve.

- I. Lack of power
 - A. Verify that the 110V GFCI outlet has power
 - B. Check all connections to ensure they have been made correctly:
 1. Cable connecting the valve coil and the timer or IR sensor
 2. Cable connecting the timer and the pushbutton (Piezo only)
 3. Cable connecting the timing device and the 24VAC transformer
 4. The 24VAC transformer and the 110V GFCI outlet
 - C. If the valve is wired correctly, the solenoid will make a “click” sound indicating that the valve has been actuated. The electronic valve is actuated by either the piezo pushbutton or the triggering of the infrared sensor (see the Start-Up Instructions for Infrared Sensors in this manual).

- II. Lack of water pressure
 - A. Check the supply to the rough-ins
 - B. Make sure the screwdriver stops are in the open position
 - C. Water pressure needs to be above 35psi to operate the valve
 1. If the water supply pressure is above 35psi but not exiting the valve:
 - a. Clean any debris from the screen on the inlet side of the solenoid valve body
 - b. Remove the screws on the valve body and clean any debris from the diaphragm

After all of the above steps have been followed, if there is still no water coming out of the spray head, there may be a damaged or defective part (see installation notice in the beginning of this manual).

Troubleshooting - Pneumatic Valves

- I. Valve will not open or deliver water
 - A. Check the plastic tubing that runs from the pushbutton actuator to the pneumatic valve for air leaks.
 - B. Make sure the checkstop on the supply to the valve is fully open. Do not partially close the checkstop for any reason as it is not a throttling valve. The checkstop should be fully open (normal operation) or fully closed (when servicing the valve).
 - C. Close checkstop and then inspect the strainer in the supply line (installed after the checkstop) to make sure the strainer is not blocked or partially blocked, prohibiting water flow.

- II. Valve will not shut off
 - A. Separate valve motor from casting by removing the four (4) #8 screws.
 - B. Inspect the water diaphragm assembly to see if bypass hole in diaphragm is blocked. Remove any debris by blowing on diaphragm or using force of air. Do not use any tool (such as straight pin) to remove any debris. Enlarging the hole will shorten or make for erratic cycling.
 - C. Check the metering screw on the timer assembly to make sure the adjustment screw is not closed too tightly. To reset, back out adjustment screw (counterclockwise) about 1-1/2" turns, and adjust for the desired cycle.

- III. Valve continues to trickle or partially deliver water after cycle is over
 - A. Inspect seating area on valve base to make sure no debris, pitting, or scoring is present.
 - B. Clean seat or replace seat as necessary.
 - C. Inspect seating area of diaphragm for debris, clean as necessary. If debris has caused permanent indentations in the rubber, it may have to be replaced.

After all of the above steps have been followed, if there is still no water coming out of the spray head, there may be a damaged or defective part (see installation notice in the beginning of this

(Page intentionally left blank)

**DRAWING: General Dimensions
 and Rough-in Detail**

 WILLOUGHBY	TITLE: AQUAFOUNT 90- 2 STATION CORNER UNIT MODEL WAF-2200-IR	DRAWING #: P155003A	REV. #: B 10/21/20 STANDARD DWG.
DIMENSIONS ARE +/- 1/4" EXCEPT AS NOTED	MATERIAL: AS NOTED	DRAWN BY: MW	DATE: 7/13/15
IR	SCALE: NOT TO SCALE		

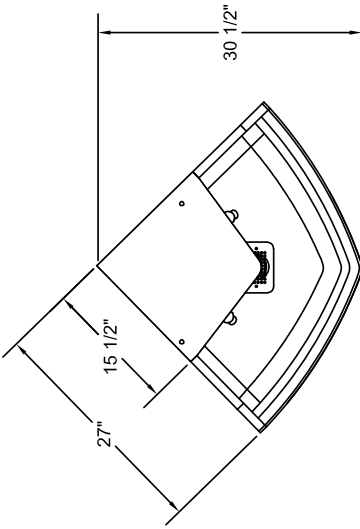

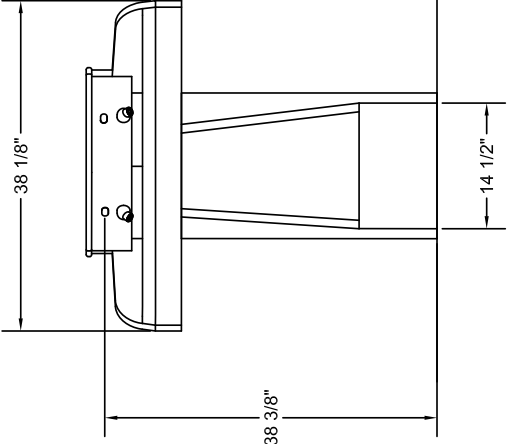



VIEW 'A'

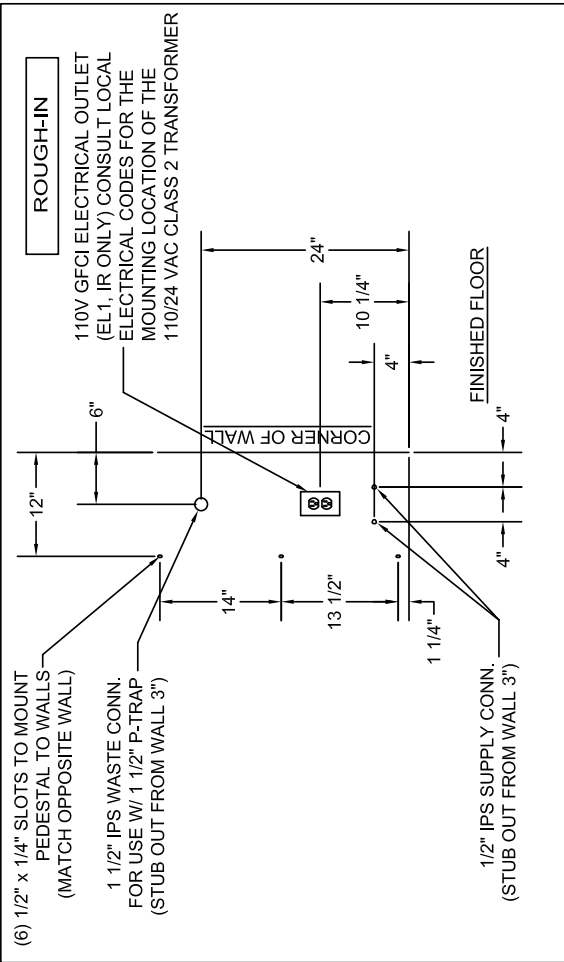

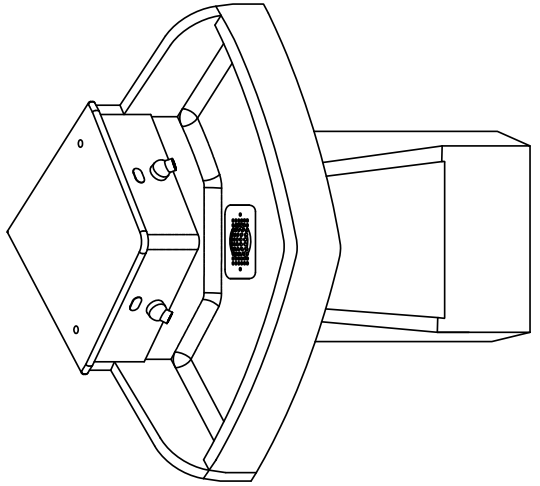

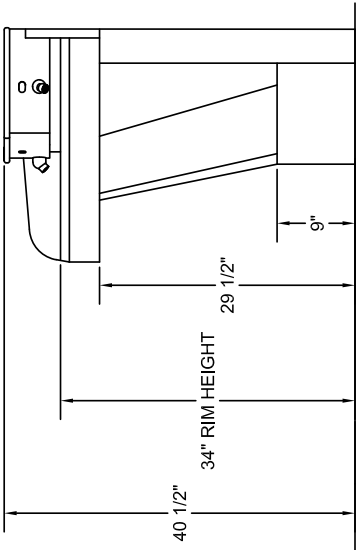

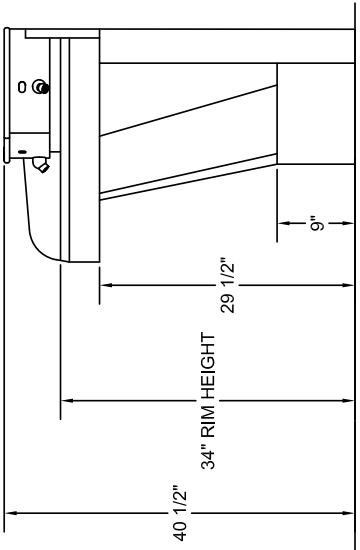

**DRAWING: General Dimensions
 and Rough-in Detail**

 WILLOUGHBY	TITLE: AQUAFOUNT 90-2 STATION OFF FLOOR CORNER UNIT MODEL WAF-2201-IR	DRAWING #: P155006A
DIMENSIONS ARE +/- 1/4" EXCEPT AS NOTED	MATERIAL: AS NOTED	REV. #: B 10/21/20
IR	DRAWN BY: MW	DATE: 7/13/15
(6) 1/2" x 1/4" SLOTS TO MOUNT PEDESTAL TO WALLS (MATCH OPPOSITE WALL)	SCALE: NOT TO SCALE	STANDARD DWG.

VIEW 'A'

VIEW 'A'

VIEW 'A'

*NOTE: 34" RIM HEIGHT SHOWN. ADJUST DIMENSIONS ACCORDINGLY FOR ALTERNATE HEIGHTS

 WILLOUGHBY	Willoughby Industries Inc. Indianapolis, Indiana		Title or Part Description: VALVE ASSY, WASHFOUNT 2-STATION (EL)		Drawing #: 803105-2EW	
	Tolerances Except as Noted 2 Places +/- .03 3 Places +/- .015 Fractions +/- 1/32" Angle +/- 1°	Material: Job Name: N/A	Drawn By: TRB Scale: 1:4	Date: 11/7/11 Part Number:	Qty: N/A	Revision #: B

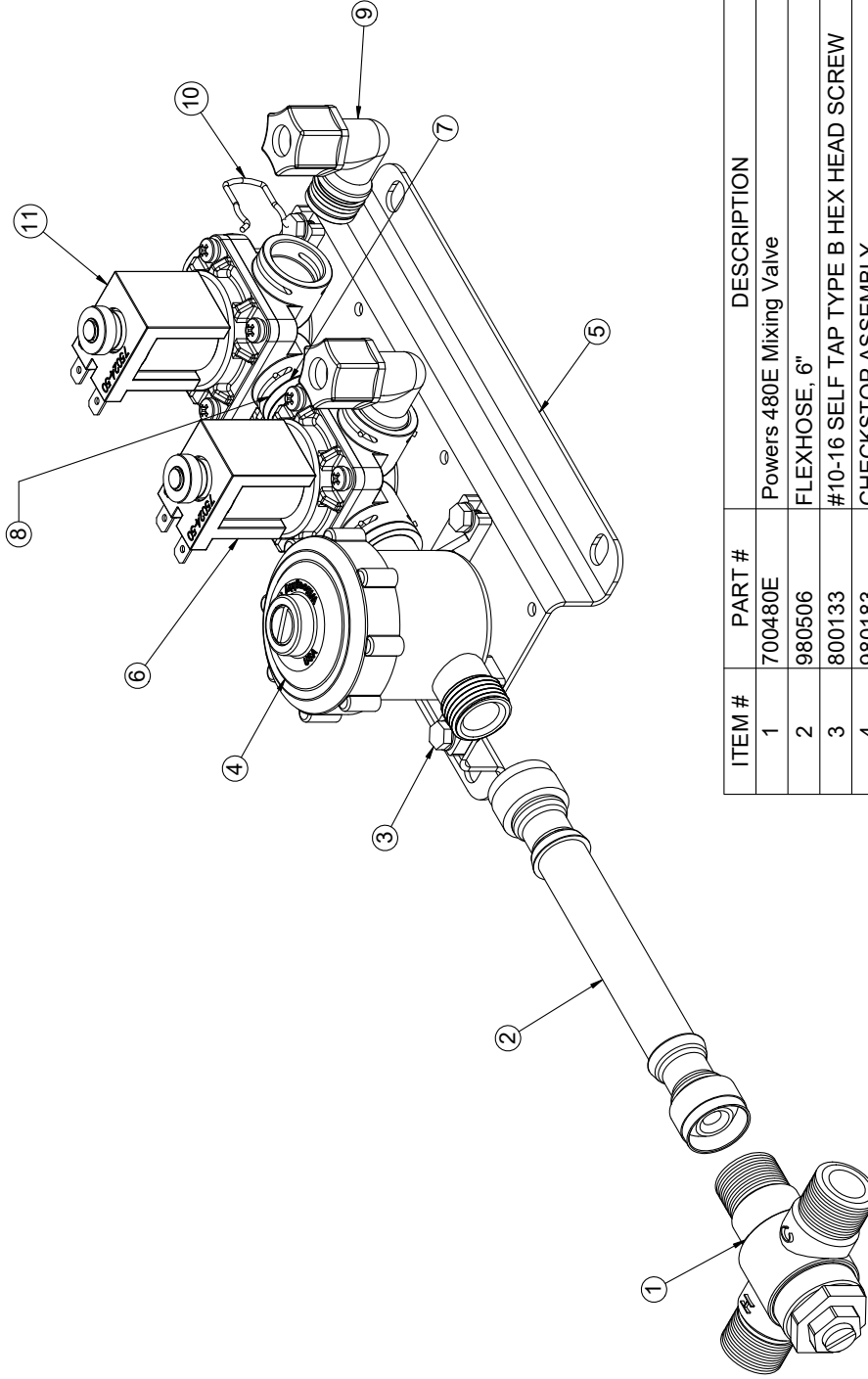

ITEM #	PART #	DESCRIPTION	QTY.
1	700480E	Powers 480E Mixing Valve	1
2	980506	FLEXHOSE, 6"	1
3	800133	#10-16 SELF TAP TYPE B HEX HEAD SCREW	6
4	980183	CHECKSTOP ASSEMBLY	1
5	9805012	PM1-MA2 VALVE BRACKET - PLASTIC	1
6	980408	E1L VALVE ASSEMBLY	1
7	980197	PLASTIC VALVE COUPLING	1
8	980164	O-RING, #015	2
9	980600A	VALVE FITTING ASSEMBLY, 3/8" ELBOW	2
10	980140	SPRING CLIP	5
11	980408PR	E1L VALVE ASSEMBLY, RIGHT - PLUGGED PORT	1
12	980520	FLEXHOSE, 20" (NOT SHOWN)	2

NOTE:
PART #12 - FLEXHOSE, 20" NOT SHOWN

DRAWING: Electronic Valve Detail

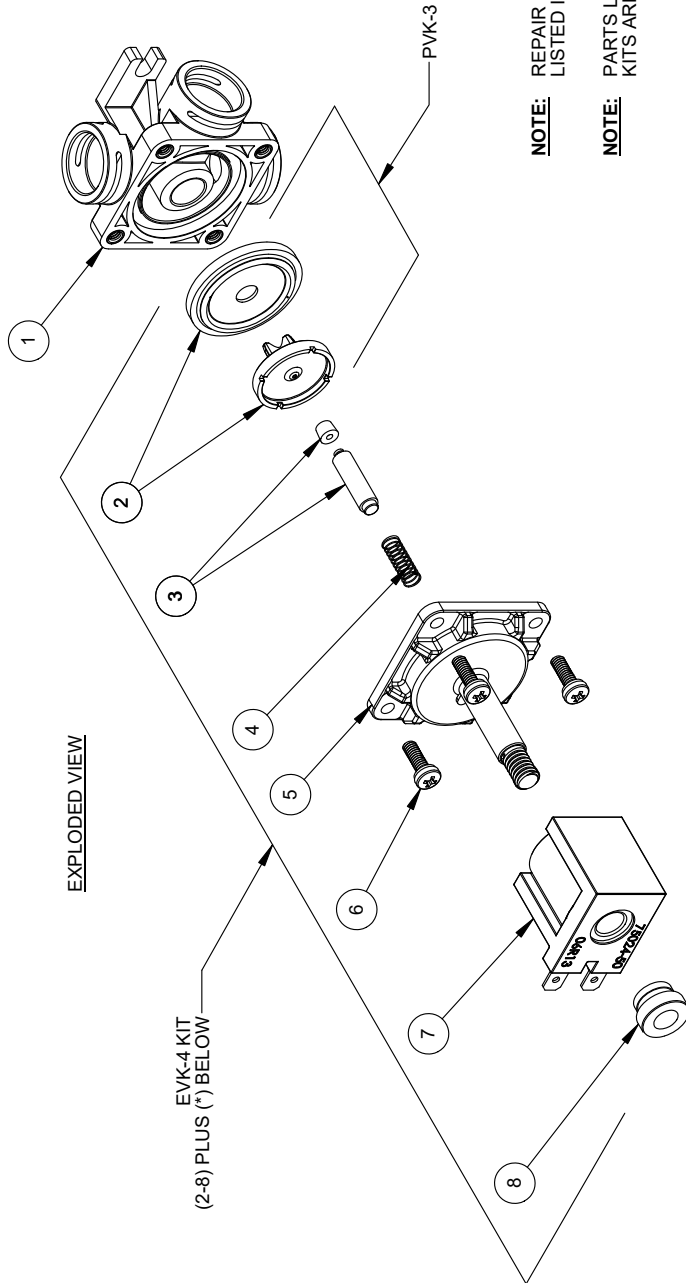

NOTE: REPAIR KIT ORDERING #'S ARE LISTED IN THE EXPLODED VIEW.

NOTE: PARTS LISTED IN THE PVK REPAIR KITS ARE NOT SOLD INDIVIDUALLY

* EVK-4 KIT INCLUDES 380897 VALVE SEAT W/ O-RING (NOT SHOWN)

ITEM #	PART #	DESCRIPTION	QTY.
1	980420	SINGLE TEMP BASE w/INSERTS (ALL PORTS OPEN)	1
2	980305	WATER SIDE DIAPHRAGM/ADAPTOR ASSY.	1
3	980565	ARMATURE BUMPER ASSEMBLY, EL VALVE	1
4	980533	SPRING, 5/8 24V VALVE	1
5	980530	ARMATURE CAP, 24V VALVE	1
6	980170A	#8-32 x 1/2 " SCREW	4
7	980532	COIL, 24V DC	1
8	980534	NYLON NUT, 5/16-18	1

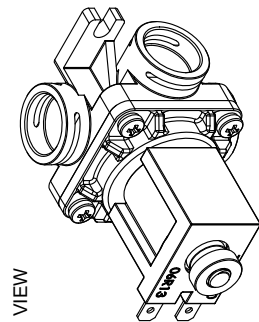

ASSEMBLED VIEW

		Willoughby Industries Inc. Indianapolis, Indiana		27 CS: 40.00 3 FCS: 40.00	SIZE: A SCALE: 1:2
TOLERANCES EXCEPT AS NOTED		TITLE / DESC: E1L VALVE ASSEMBLY (ALL PORTS OPEN)		PART #: 980408	
REVISION ORIG: TRB 09/23/09 STANDARD		REV: TRB 03/15/11		SHEET: 1 OF 1	

DRAWING: Pneumatic Valve Detail

 WILLOUGHBY	Willoughby Industries Inc. Indianapolis, Indiana	Title or Part Description: VALVE ASSY, WASHFOUNT 2-STATION (PNEUMATIC)		Drawing #: 803105-2PW	
	Tolerances Except as Noted	2 Places +/- .03 3 Places +/- .015 Fractions +/- 1/32" Angle +/- 1°	Material: Job Name: N/A	Drawn By: TRB Scale: 1:8	Date: 11/7/11 Qty: N/A
				Approved By:	Sheet: 1 Of 1

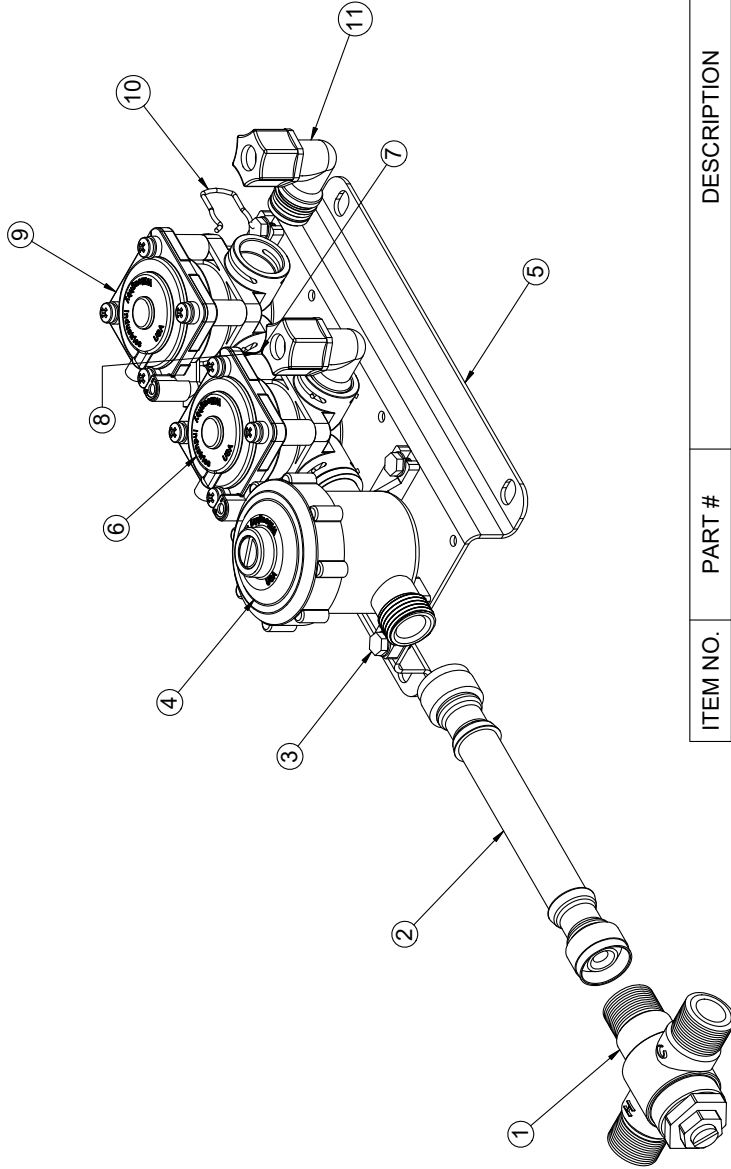

ITEM NO.	PART #	DESCRIPTION	QTY.
1	700480E	Powers 480E Mixing Valve	1
2	980506	FLEXHOSE, 6"	1
3	800133	#10-16 SELF TAP TYPE B HEX HEAD SCREW	6
4	980183	CHECKSTOP ASSEMBLY	1
5	9805012	PM1-MA2 VALVE BRACKET - PLASTIC	1
6	980406R	PNEUMATIC VALVE ASSEMBLY	1
7	980197	PLASTIC VALVE COUPLING	1
8	980164	O-RING, #015	2
9	980406PR	PNEUMATIC VALVE ASSEMBLY, RIGHT - PLUGGED PORT	1
10	980140	SPRING CLIP	5
11	980600A	VALVE FITTING ASSEMBLY, 3/8" ELBOW	2
12	980520	FLEXHOSE, 20" (NOT SHOWN)	2

NOTE:
 PART #12 - FLEXHOSE, 20" NOT SHOWN

DRAWING: Pneumatic Valve Detail

ITEM #	PART #	DESCRIPTION	QTY.
1	980420	SINGLE TEMP BASE w/INSERTS (ALL PORTS OPEN)	1
2	980305	WATER SIDE DIAPHRAGM/ADAPTOR ASSY.	1
3	980310	WATER SIDE DISK ASSEMBLY	1
4	980136	SPRING, WATER SIDE DIAPHRAGM	1
5	980126	BARRIER CUP	1
6	980127	O-RING M1.5x32 BUNA-70	1
7	980410	METERING VALVE BODY ASSEMBLY	1
8	980135	SPRING, AIR SIDE MAGNET	1
9	980405	METERING VALVE MAGNET/CUP ASSEMBLY	1
10	980130	DIAPHRAGM, AIR SIDE, PNEUMATIC METERING VALVE	1
11	980134	AIR SIDE SPRING	1
12	380801M	AIR SIDE TOP COVER	1
13	980001A	#8-32 x 1 1/4" SCREW	4

NOTE: PARTS LISTED IN THE PVK REPAIR KITS ARE NOT SOLD INDIVIDUALLY

NOTE: REPAIR KIT ORDERING #'S ARE LISTED IN THE EXPLODED VIEW.

NOTE: PVK-1M, PVK-2, & PVK-3 PARTS ARE AVAILABLE IN KIT FORM ONLY.

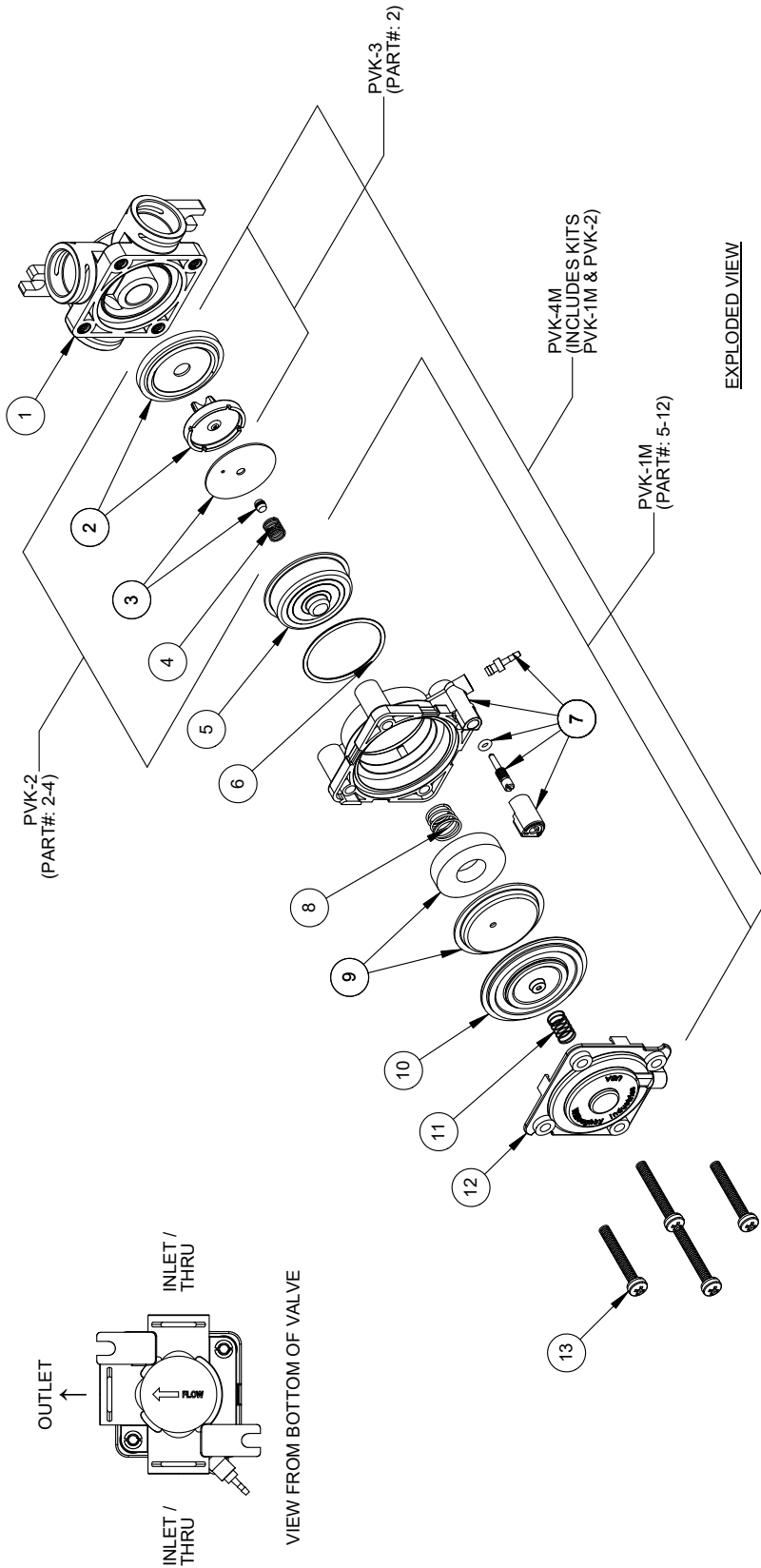
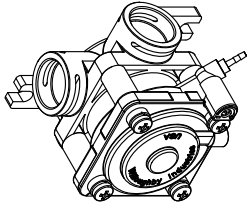

Willoughby Industries Inc. Indianapolis, Indiana		TITLE / DESC: PNEUMATIC METERING VALVE ASSEMBLY - (RIGHT)		PART #: 980406R	
TOLERANCES EXCEPT AS NOTED		2 PLS: #003 SIZE: A		REVISION / ORIG: TRB 10/18/12 STANDARD	
FRACTIONS: 1/32"		SCALE: 1:2.5		REV: MW 8/31/16 SHEET: 1 OF 1	
WILLOUGHBY		REF:		A	

DRAWING: 9V Battery Operated Valve Detail

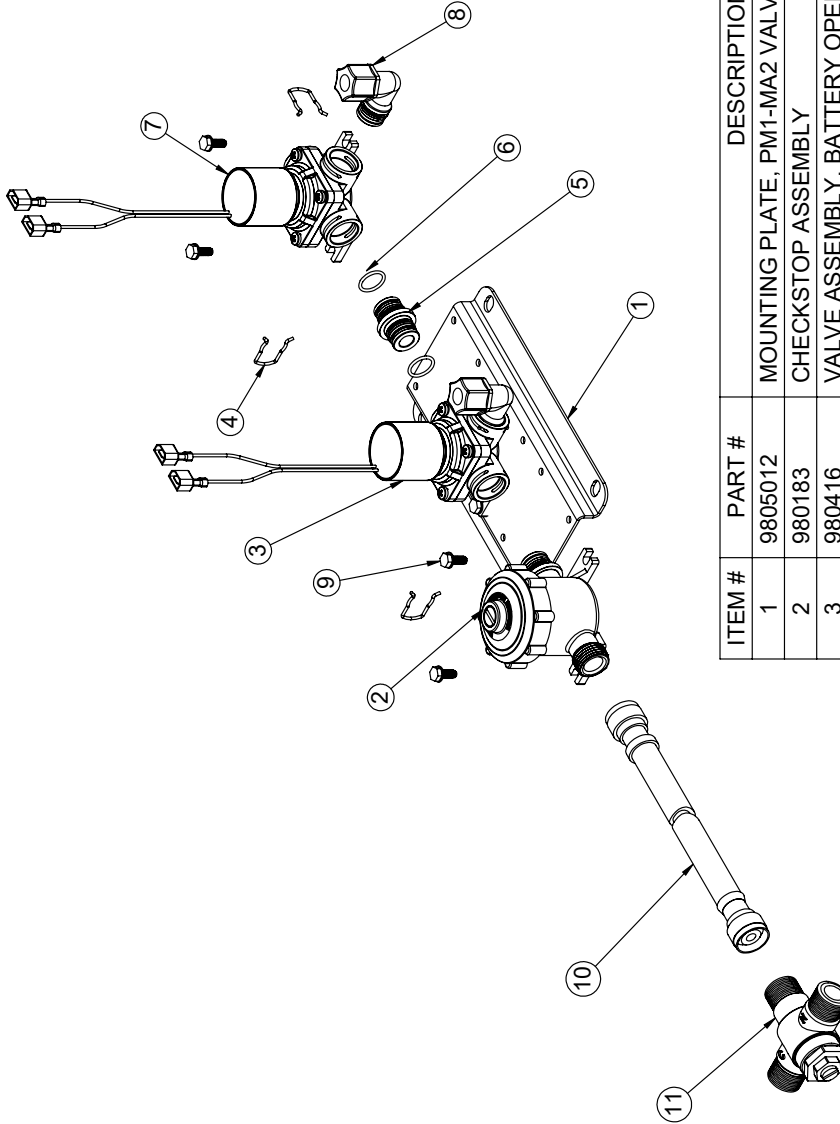

ITEM #	PART #	DESCRIPTION	QTY.
1	9805012	MOUNTING PLATE, PM1-MA2 VALVE	1
2	980183	CHECKSTOP ASSEMBLY	1
3	980416	VALVE ASSEMBLY, BATTERY OPERATED	1
4	980140	SPRING CLIP, ROUND	5
5	980197	PLASTIC VALVE COUPLING	1
6	980164	O-RING, #015	2
7	980416PR	VALVE ASSY, BATTERY OPERATED, RH PLUGGED PORT	1
8	980600A	VALVE FITTING ASSEMBLY, 3/8" ELBOW	2
9	800133	#10-16 SELF TAP TYPE B HEX HEAD SCREW	6
10	980506	6" FLEX HOSE, 1/2 F.I.P CONNECTION	1
11	700480ELF	MIXING VALVE, TMV, LEAD FREE, LF-E480	1
12	980520	20" FLEX HOSE, 1/2 F.I.P CONNECTION	2

NOTE:
PART #12 - FLEXHOSE, 20" NOT SHOWN



Willoughby Industries, Inc.
Indianapolis, Indiana
TOLERANCES EXCEPT AS NOTED
2 PLS: #003
3 PLS: #0016
FRAGILE: #1
SCALE: 1:4
MATERIAL: SEE BOM
REV: A

PART #:		803105-2BW
TITLE / DESC:		VALVE ASSY, WASHFOUNT 2-STATION (BO)
REVISION	ORIG:	NAL 4/19/21
REV:	NAL	4/19/21
STANDARD		
SHEET		1 OF 1

DRAWING: 9V Battery Operated Valve Detail

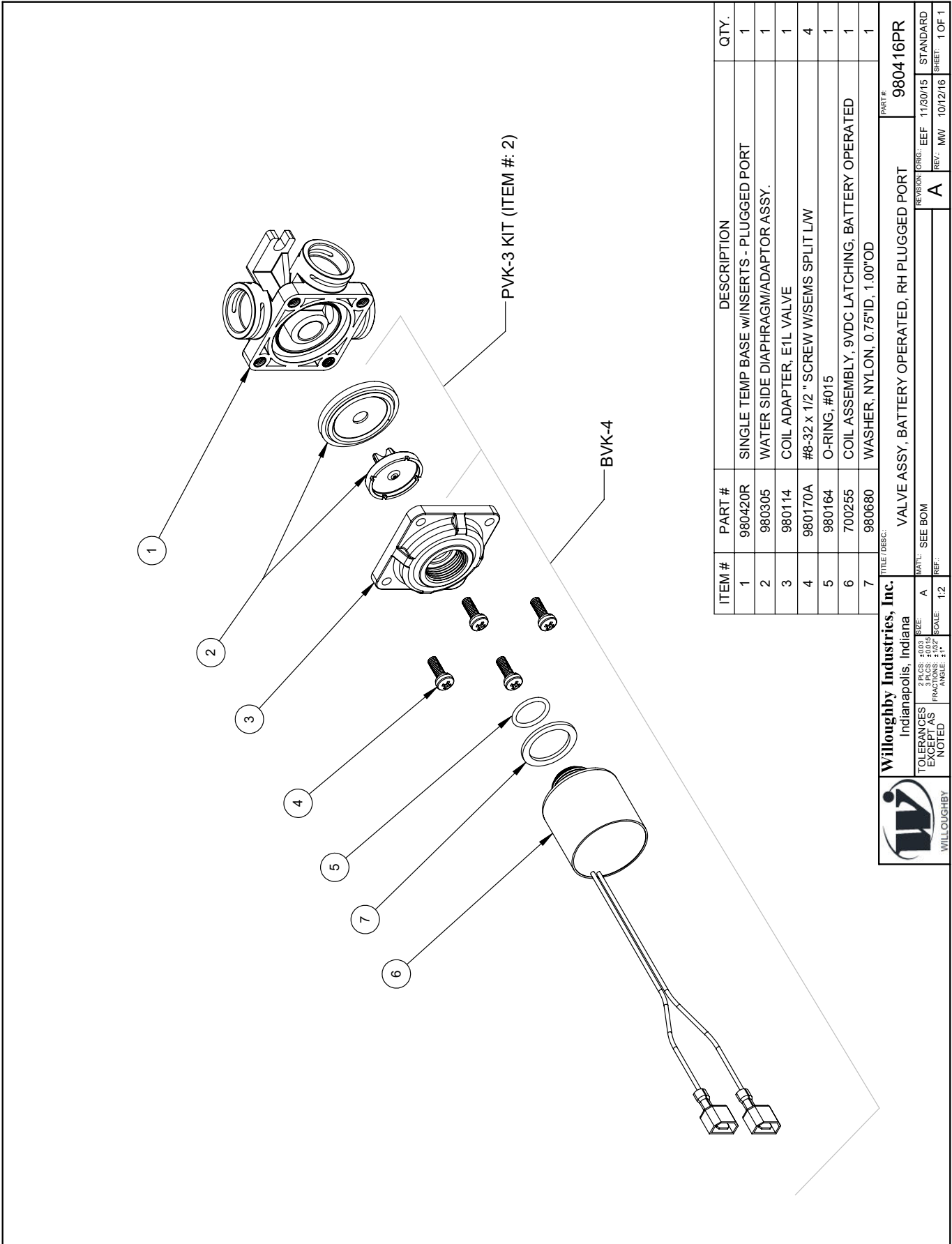

ITEM #	PART #	DESCRIPTION	QTY.
1	980420R	SINGLE TEMP BASE w/INSERTS - PLUGGED PORT	1
2	980305	WATER SIDE DIAPHRAGM/ADAPTOR ASSY.	1
3	980114	COIL ADAPTER, E1L VALVE	1
4	980170A	#8-32 x 1/2" SCREW w/SEMS SPLIT LW	4
5	980164	O-RING, #015	1
6	700255	COIL ASSEMBLY, 9VDC LATCHING, BATTERY OPERATED	1
7	980680	WASHER, NYLON, 0.75"ID, 1.00"OD	1

Willoughby Industries, Inc. Indianapolis, Indiana		TITLE / DESC: VALVE ASSY, BATTERY OPERATED, RH PLUGGED PORT		PART #: 980416PR	
TOLERANCES EXCEPT AS NOTED	2 PLS: ±0.03 3 PLS: ±0.15 FRAC: ANGLES: 1"	MATL: SEE BOM	REV: MW	ORIG: EEF	STANDARD: STANDARD
SCALE: 1:2			REV: MW	10/12/16	SHEET: 1 OF 1

DRAWING: Push Button Detail

PIEZO HEAD KIT DETAIL

✓	WIRE TERMINATOR	INV. #
	BARE STRIPPED WIRE	701179
	1/4" FEMALE SPADE CONNECTION	701179-C

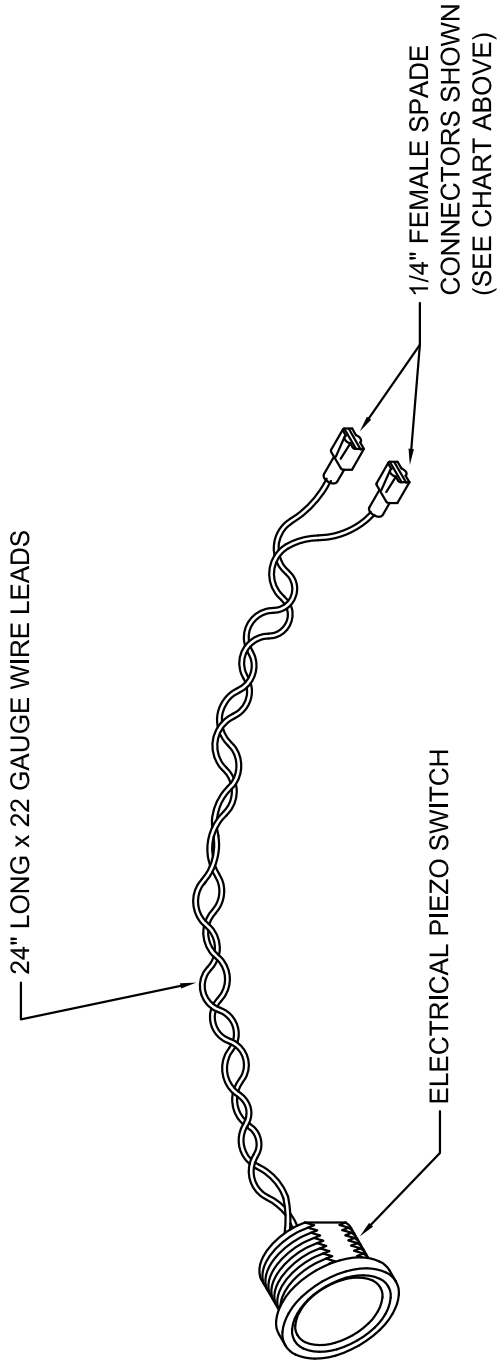

PIEZO SWITCH SPECIFICATIONS

PIEZO SWITCH HOUSING:

- MATERIAL: STAINLESS STEEL
- MOUNTING GEOMETRY: DOUBLE 'D' HOUSING
- SUPPLIED WITH NUT FOR MOUNTING
- 2 FT. LEADS INTEGRAL TO SWITCH (EXTENSION CABLES CAN BE SPECIAL ORDERED)
- EXTERNAL HOUSING OF SWITCH ELECTRICALLY ISOLATED FROM CIRCUITRY OF SWITCH

OPERATIONAL RATINGS:

- ACTUATION FORCE: LESS THAN 5 LBS.
- MAXIMUM VOLTAGE: 36 VOLTS AC/DC
- MAXIMUM AMPERAGE: 100 MA

DRAWING: Push Button Detail

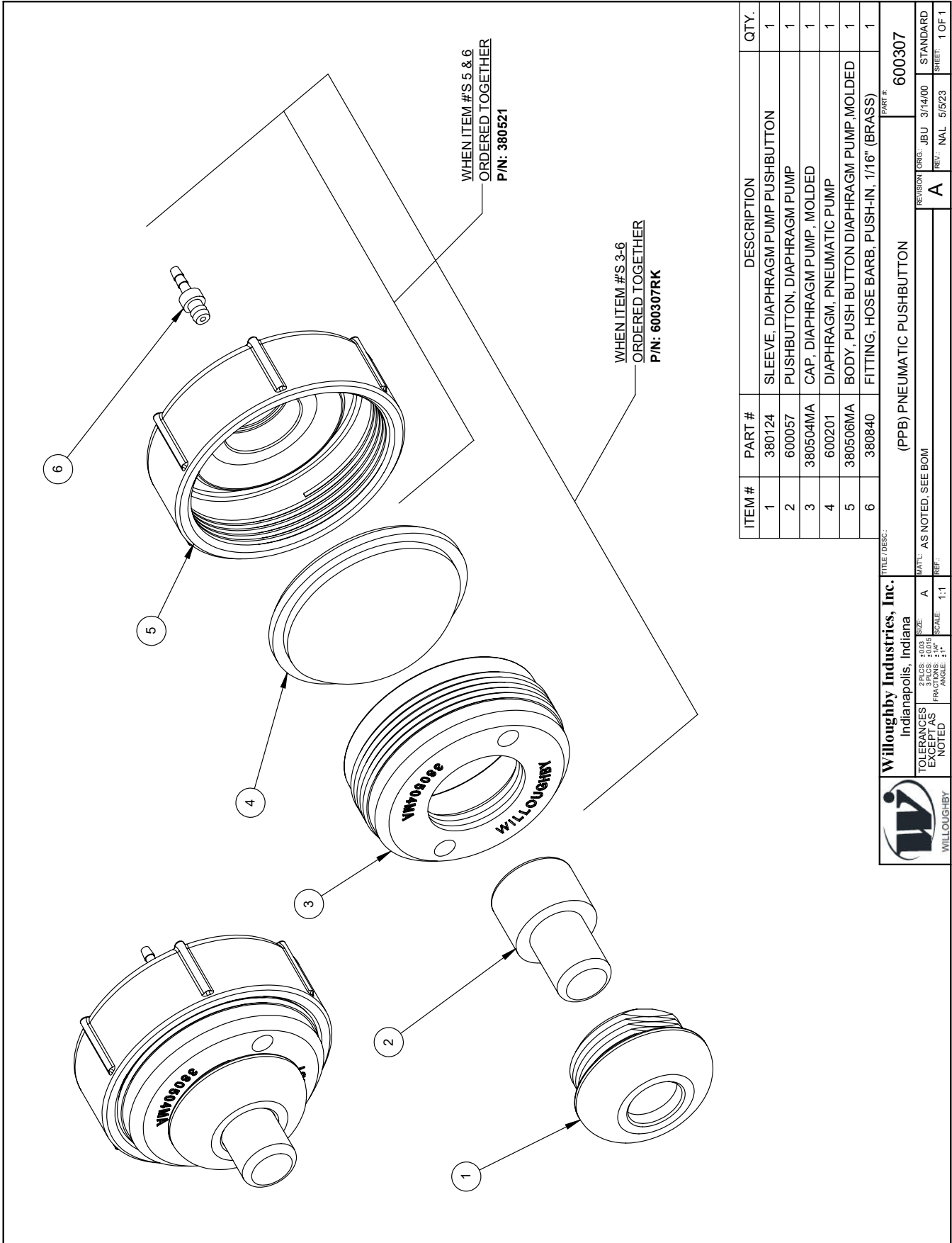

ITEM #	PART #	DESCRIPTION	QTY.
1	380124	SLEEVE, DIAPHRAGM PUMP PUSHBUTTON	1
2	600057	PUSHBUTTON, DIAPHRAGM PUMP	1
3	380504MA	CAP, DIAPHRAGM PUMP, MOLDED	1
4	600201	DIAPHRAGM, PNEUMATIC PUMP	1
5	380506MA	BODY, PUSH BUTTON DIAPHRAGM PUMP, MOLDED	1
6	380840	FITTING, HOSE BARB, PUSH-IN, 1/16" (BRASS)	1

Willoughby Industries, Inc. Indianapolis, Indiana		TITLE / DESC: (PPB) PNEUMATIC PUSHBUTTON PART #: 600307	
2 PCS: 4003 3 PCS: 20015 EXCEPT AS NOTED	MATL: A SIZE: A FINISH: 1"	REVISION ORG. JBU: 3/14/00 REV: NAL: 5/5/23 A	STANDARD SHEET: 1 OF 1
TOLERANCES EXCEPT AS NOTED ANGLE: 1"		REF:	
SCALE: 1:1		AS NOTED, SEE BOM	

DRAWING: Spray Head Detail

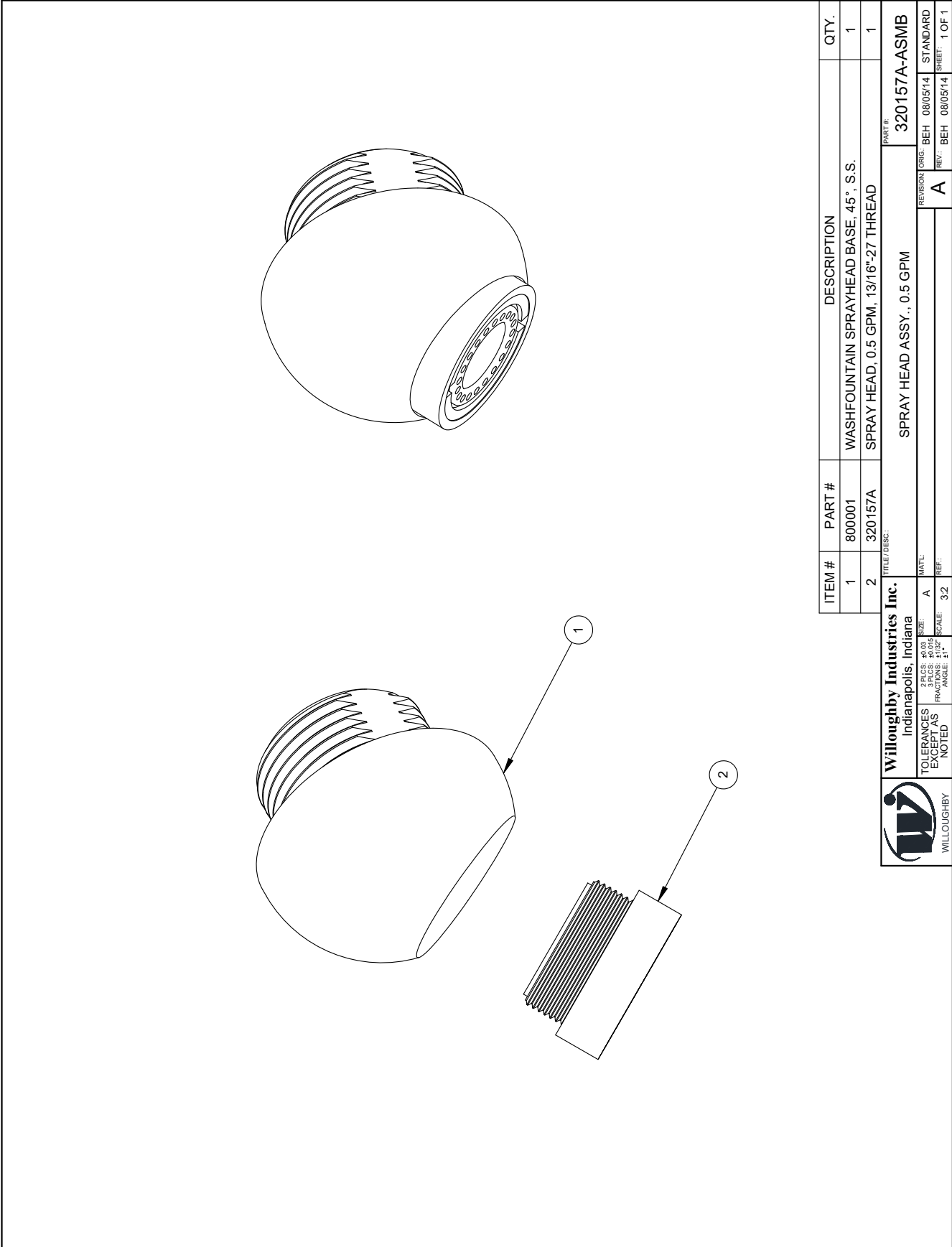

ITEM #	PART #	DESCRIPTION	QTY.
1	800001	WASHFOUNTAIN SPRAYHEAD BASE, 45°, S.S.	1
2	320157A	SPRAY HEAD, 0.5 GPM, 13/16"-27 THREAD	1

		Willoughby Industries Inc. Indianapolis, Indiana	
2 PLS. #0.03	SIZE: A	REVISION	DATE: 08/05/14
3 PLS. #0.015	FRONT ANGLE: 32°	REV: BEH	STANDARD
NOTED	SCALE: 1" = 1"	REV: BEH	08/05/14
TITLE/DESC: SPRAY HEAD ASSY., 0.5 GPM PART #: 320157A-ASMIB		SHEET: 1 OF 1	

DRAWING: Liquid Soap Dispenser Detail

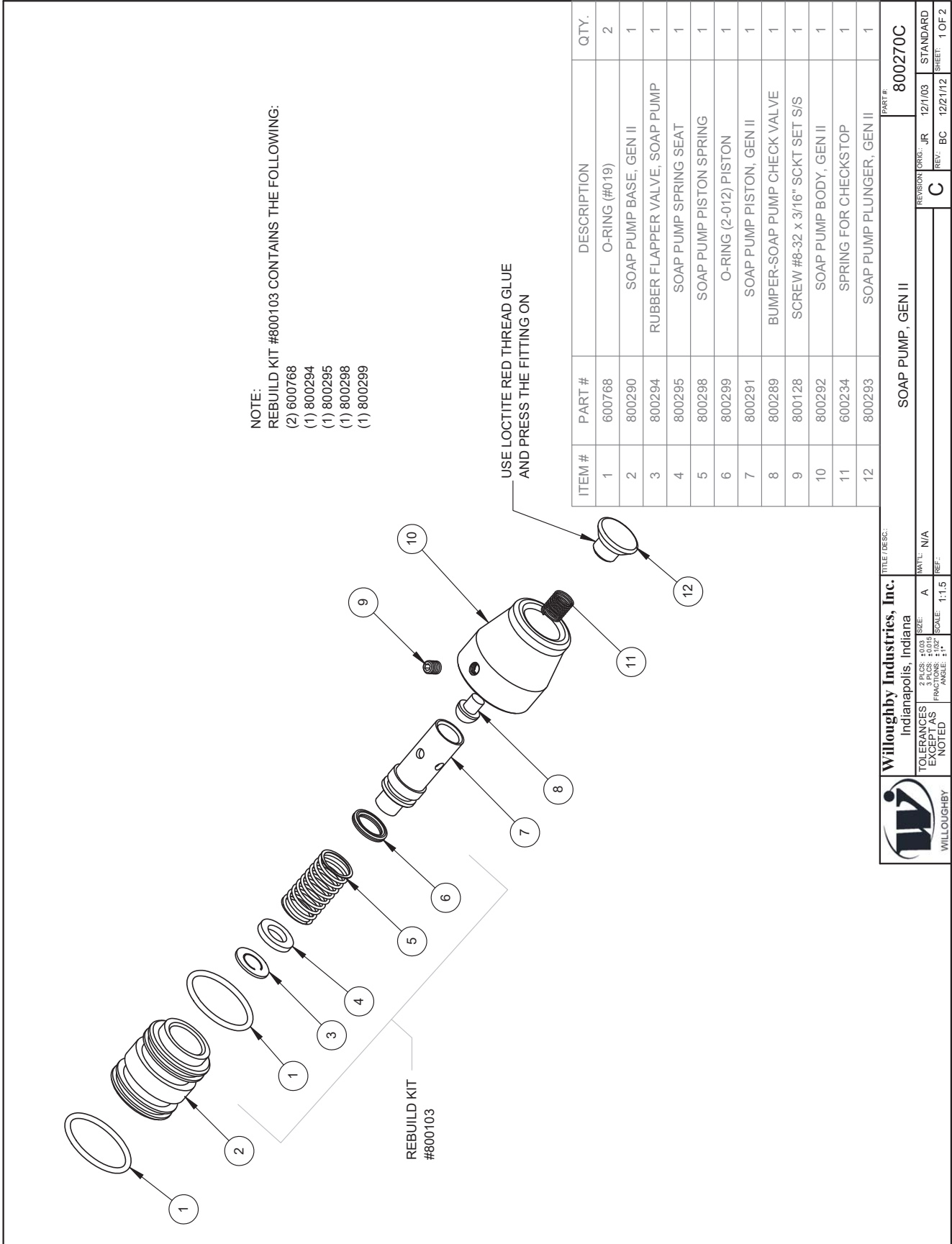

Willoughby Industries, Inc.
Indianapolis, Indiana

TOLERANCES EXCEPT AS NOTED
FRAGILE NOTED

SCALE: 1:1.5

DATE: 12/1/03

REV: JR

REV: BC

PART #: 800270C

STANDARD SHEET: 1 OF 2

Warranty

Solid surface products are a homogenous blend of resins, mineral filler and colorant manufactured for panels, molded and/or shaped products and components. Solid surface products provide a luxurious appearance with the durability of stain proof, impact resistant, burn resistant material with the ease of maintenance and cleaning.

Willoughby Industries, Inc. warrants to commercial and institutional purchasers only that each unit will be free from defects in workmanship and materials under normal use and service upon the following terms and conditions. The period during which components are warranted is as follows:

1. Solid surface components are warranted for 2 years from date of shipment.
2. All other components warranted for 1 year from date of shipment.

This warranty does not cover installation or any other labor charges and does not apply to any components damaged by accident, abuse, improper installation or improper maintenance. This warranty does not cover any installation that did not comply with national, state and local building, plumbing or electrical codes. The warranty is limited to replacing or repairing at manufacturer's option, transportation charges prepaid by the purchaser, any component or part which upon our inspection shall be deemed as defective within the limitations of this warranty. The replacement or repair of defective units as stated in this warranty shall constitute the sole remedy of the purchaser and the sole liability of Willoughby Industries, Inc. Willoughby Industries, Inc. shall not otherwise be liable under any indirect damages caused by defects in the repair or replacement thereof.

This warranty only extends to commercial and industrial purchasers and does not extend to any others, including consumer customers of commercial institutional purchasers. This warranty is in lieu of all other warranties, expressed or implied, including implied warranty of merchantability or fitness for a particular purpose or otherwise.