

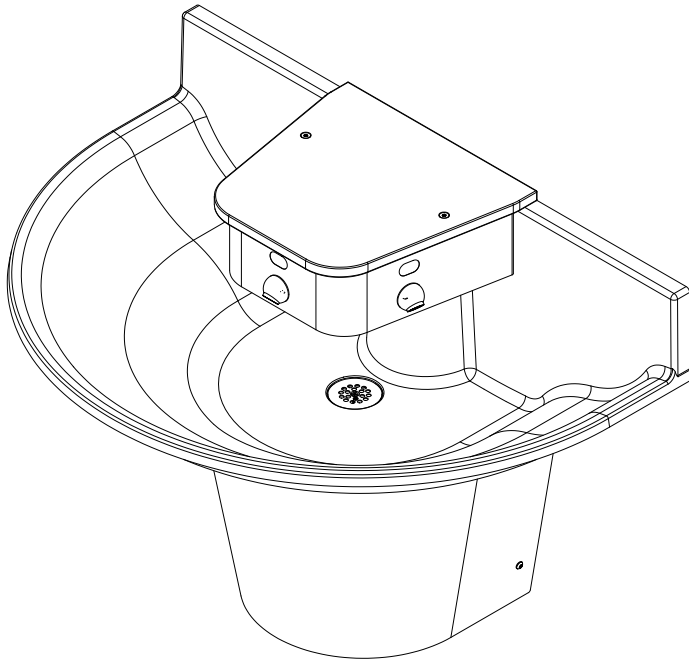

Installation & Operation Manual

WAF-3603 Series

Aquafount® 36" 180° Solid Surface Washfountain Electronic/Pneumatic



WAF-3603

 **IN COMPLIANCE
WITH A.D.A. 2010**

** Wall mounted models only. Follow the applicable instructions in this manual to ensure installation complies with A.D.A. requirements.*

Table of Contents

Pre-Installation Information.....	3
Physical Dimensions	4
Rough-In Dimensions.....	6
Required Installation Supplies	9
Parts List.....	10
Exploded-view Drawing	11
Hardware Identification Chart.....	12
Installation Instructions	
Step 1: Pedestal Mounting.....	13
Step 2: Mounting Basin.....	14
Step 3: Drain Assembly	15
Step 4A: Connections for Infrared/Piezo Actuators.....	16
Step 4B: Connections for Pneumatic Actuators	17
Step 5: Final Assembly	18
JACO Fitting Instructions.....	19
Mixing Valve Instructions	20
Infrared Sensor Installation Instructions	21
Pneumatic Valve Operation Details	22
Liquid Soap Specification and Maintenance.....	23
Care and Maintenance	24
Troubleshooting	
Infrared Sensors	25
Electronic Valves	26
Pneumatic Valves	27
Replacement Part Numbers	28
Drawings.....	
General Dimensions	29
Valve Details	30
Miscellaneous Details.....	34
Warranty	38



Willoughby Industries, Inc.

5105 West 78th Street
Indianapolis, IN 46268
Toll Free: (800) 428-4065
Local: (317) 875-0830
Fax: (317) 875-0837
www.willoughby-ind.com

WILLOUGHBY

Rev. 8/2023

MADE IN THE U.S.A.



(Page intentionally left blank)

Pre-Installation Information

Installation notice!

Check Rough-In location **PRIOR** to installation

Flush lines thoroughly **PRIOR** to hook-up

When installing the **Willoughby Industries' WAF-3603 Series** washfountain system:

Before Step 1 of the installation instructions, ensure that rough-ins are in the correct location.

The valve assembly, including the spray head, **MUST NOT BE** connected until *after* all lines have been flushed to remove the small particles of debris that are inherent with new construction projects and all chemicals that are used in flushing are purged from the system.

Chemicals used in flushing plumbing systems can attack the internal components of the valve and spray head and severely damage them, so any flushing of the system must be followed by a full flushing with pure water to clear any harsh chemicals remaining in the system. Debris in the system if allowed to enter the valve assembly and spray head can cause poor performance or outright failure.

Again **DO NOT** attempt to connect the valve assembly and spray head until *after* all flushing is complete and pure water is the only media that will be passing through the system. Damage to the valve assembly or spray head caused by harsh chemicals or debris will not be covered by the manufacturer's warranty.

Installation notice!

Check Rough-In location **PRIOR** to installation

Flush lines thoroughly **PRIOR** to hook-up

Physical Dimensions- WAF-3603 (Wall-mounted)

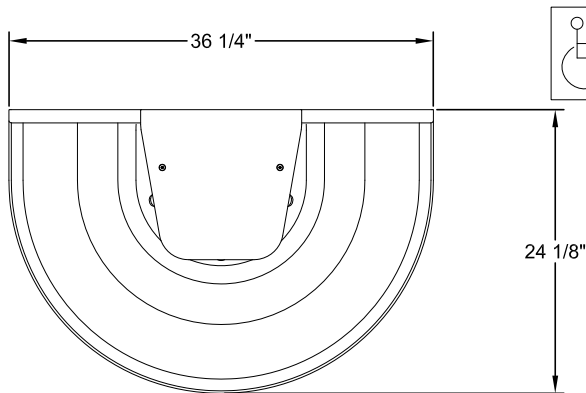

 IN COMPLIANCE WITH A.D.A. 2010

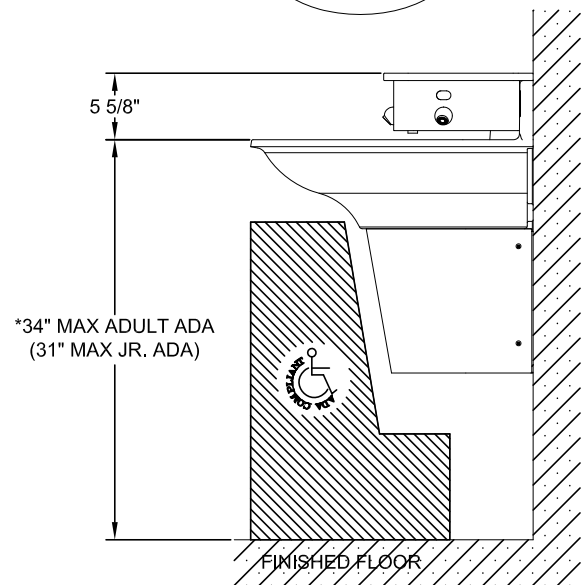
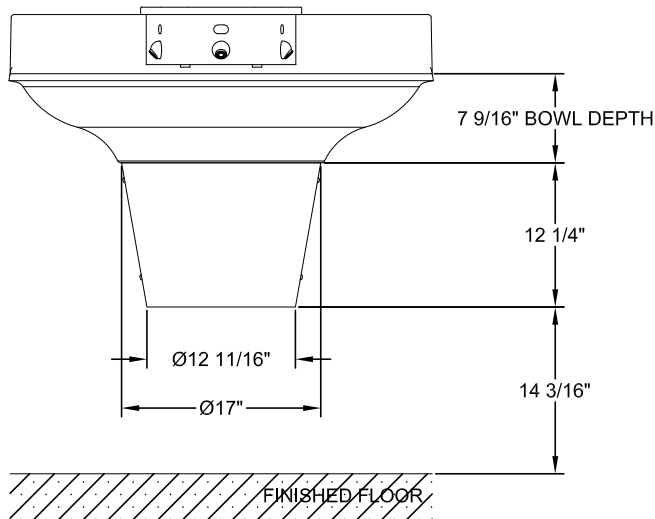
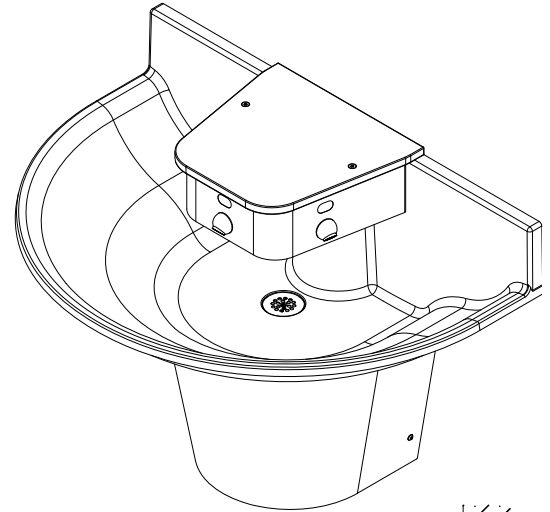

*NOTE: 34" RIM HEIGHT SHOWN, ADJUST DIMENSIONS ACCORDINGLY FOR ALTERNATE HEIGHTS

Physical Dimensions- WAF-3603-FL (Floor-mounted)

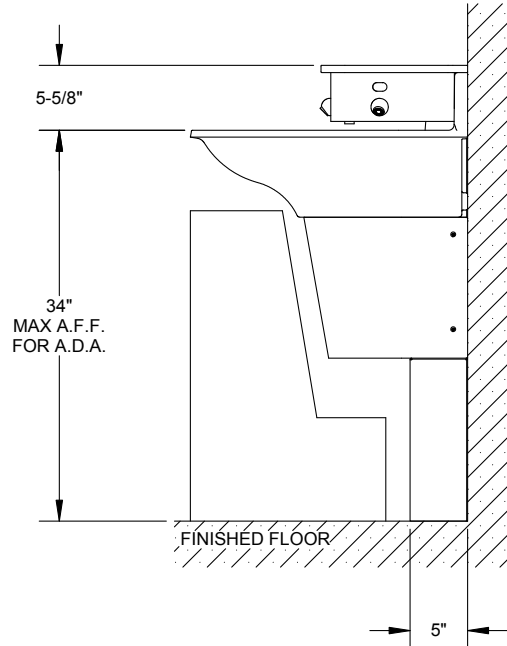
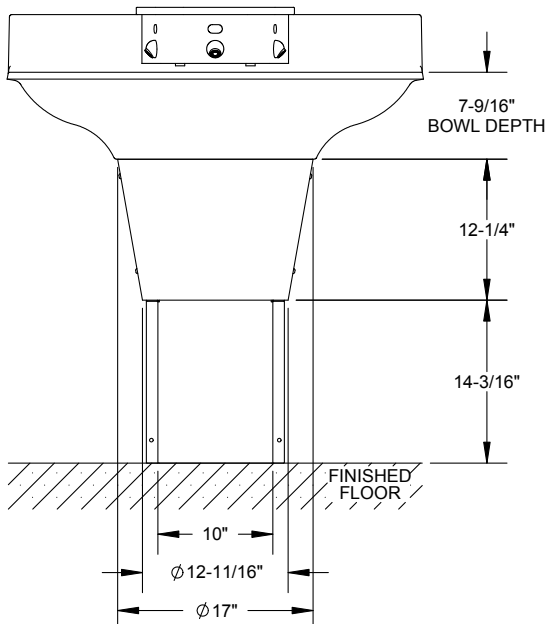
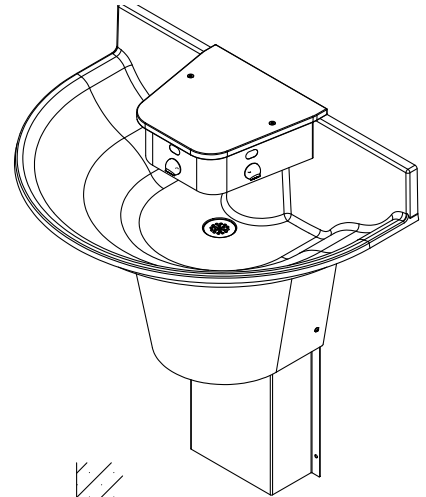
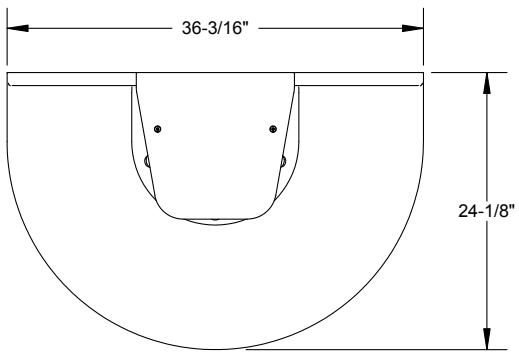

Rough-In Dimensions- WAF-3603 (Wall-mounted)

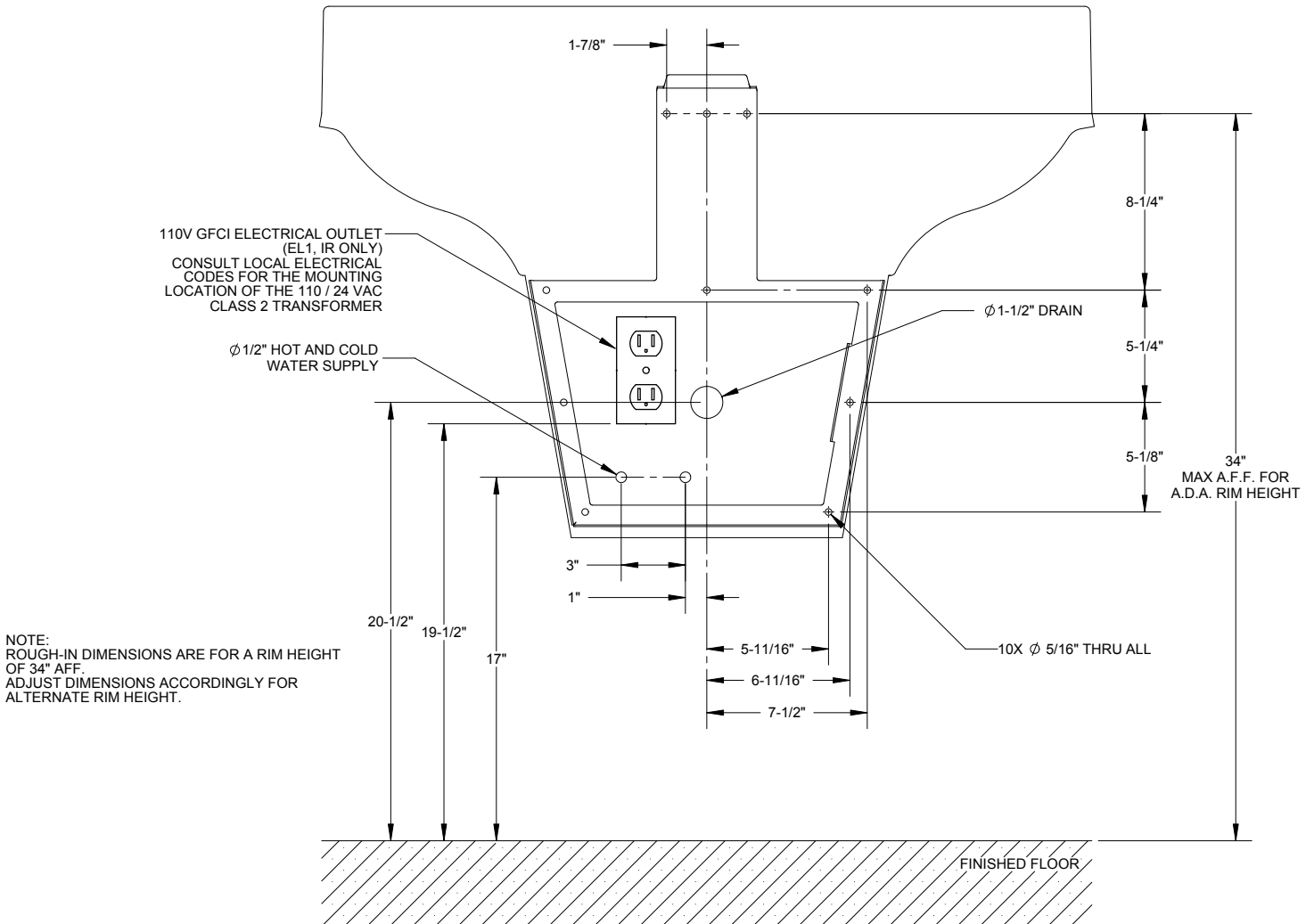

Rough-In Dimensions- WAF-3603-FL (Floor-mounted)

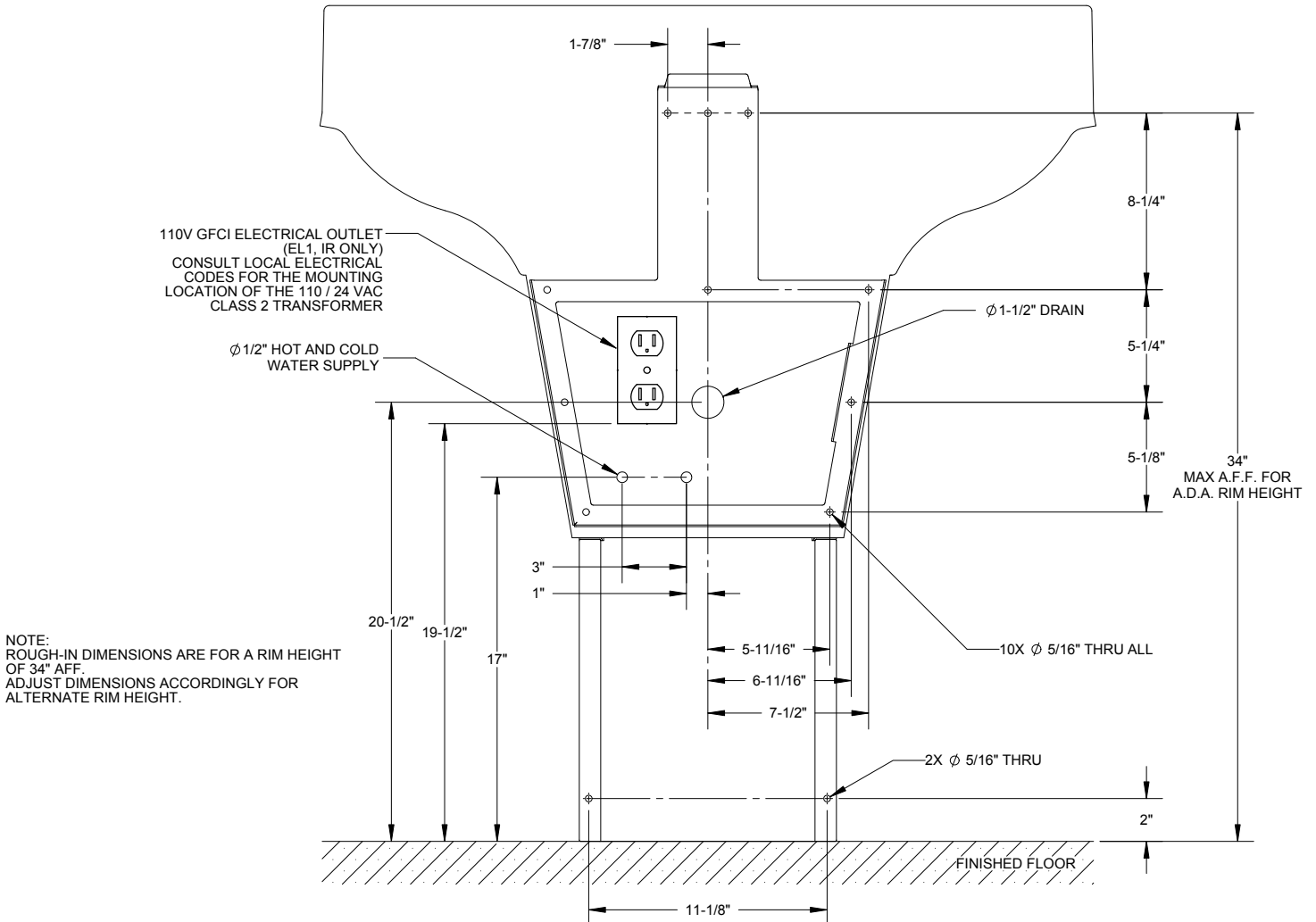

(Page intentionally left blank)

Required Installation Supplies

- Proper mounting hardware
- Hardware for waste outlet connections
- Gasket for waste outlet connection
- Shims (for installation if necessary)
- Supply piping
- Silicone caulk

☐ WARNING: Willoughby Industries does not assume any responsibility for personal injury or damage to equipment due to an improperly installed WAF-3603 Series washfountain.

Parts List

ITEM #	DESCRIPTION	PART NUMBER (P/N) - 3-STATION
1	36" HALF-ROUND BASIN - SOLID SURFACE	800603C-XX
2	TOP COVER - SOLID SURFACE	800333LP-XX
3	PEDESTAL ASSEMBLY (WALL-MOUNT)	S600491
	PEDESTAL ASSEMBLY (FLOOR-MOUNT)	S600492
4	PEDESTAL BACKPLATE	S600486
5	PEDESTAL SHROUD (WALL-MOUNT)	S600487
	PEDESTAL SHROUD (FLOOR-MOUNT)	S600493
6	ACTUATOR HOUSING / VALVE HEAD KIT - INFRARED	WAF3603-I
	ACTUATOR HOUSING / VALVE HEAD KIT - PIEZO	WAF3603-E
	ACTUATOR HOUSING / VALVE HEAD KIT - PNEUMATIC	WAF3603-P
7	STND. SPRAY HEAD ASSEMBLY- WAF (AERATOR SPRAY HEAD, 0.5 GPM- #320157A) (SPRAY HEAD BASE, 45°- #800001)	320157A-ASMB
8	DRAIN ASSEMBLY (WAF)	380281
9-12	HARDWARE KIT	800258
NOT SHOWN	PEDESTAL LOWER SHROUD (FLOOR-MOUNT)	S600336
	INFRARED SENSOR	700150
	PIEZO PUSHBUTTON	701179-C
	ACTUATOR PUSHBUTTON	600307
	ELECTRONIC VALVE ASSEMBLY	803106-3EL
	PNEUMATIC VALVE ASSEMBLY	803106-3PW
	BATTERY OPERATED VALVE ASSEMBLY	803106-3BW
	CHECKSTOP ASSEMBLY	980183
	STAINLESS STEEL FLEX HOSE (6")	980506
	STAINLESS STEEL FLEX HOSE (20")	980520
	POWERS HYDROGUARD T/P (LFe480)	700480ELF

*XX REPRESENTS THE WASH FOUNTAIN COLOR

WHITE GRANITE=WG
 SAND STONE=SS
 GRAY GRANITE=GG
 BLACK GRANITE=BG
 SEA GREEN=SG
 NOCTURNAL BLUE=NB
 GLACIER WHITE=GW
 BONE=B

Exploded-view Drawing

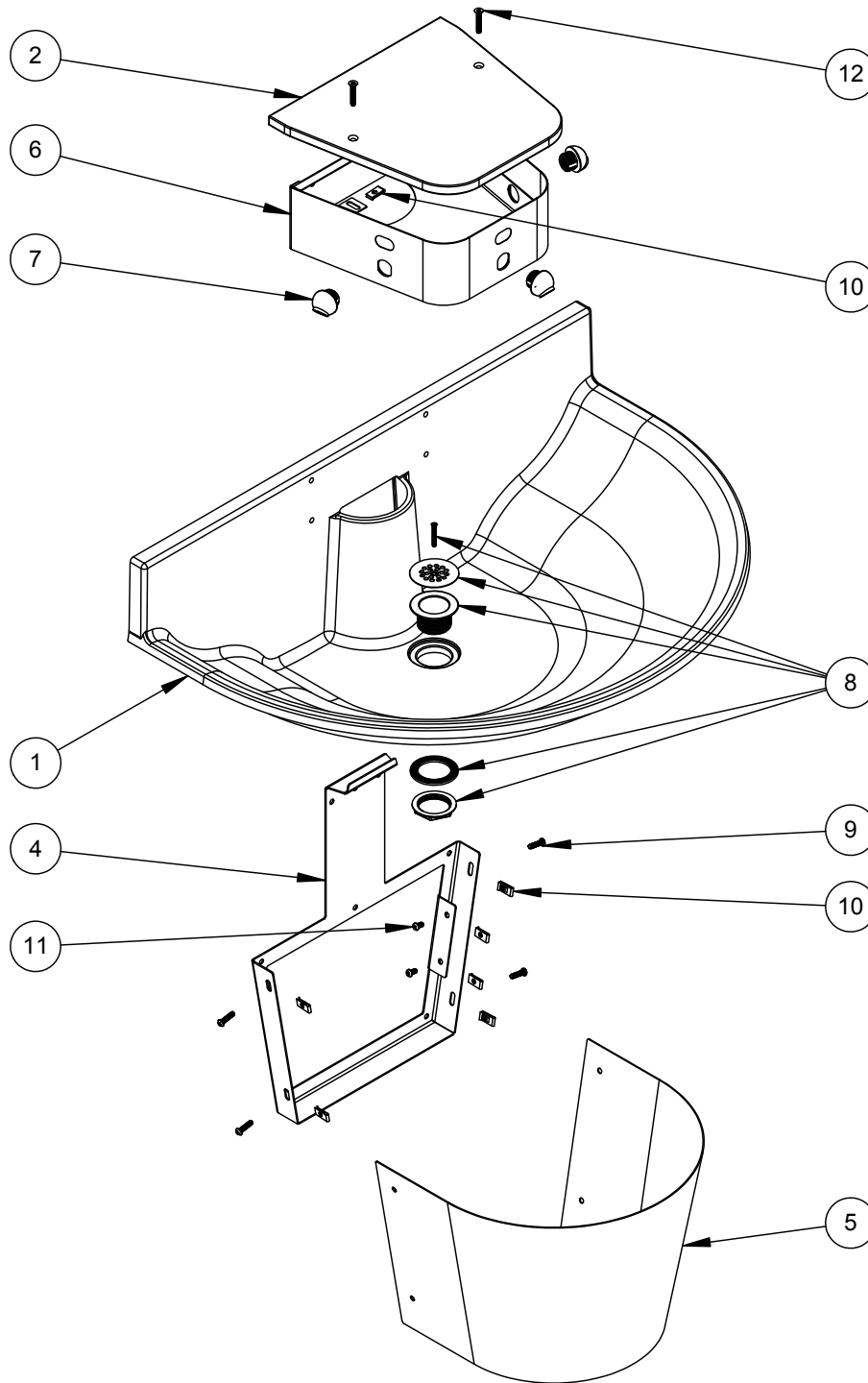

***WAF-3603 (WALL-MOUNTED UNIT) SHOWN.**
SEE PARTS LIST FOR WAF-3603-FL
(FLOOR-MOUNTED) SPECIFIC PART NUMBERS.

Hardware Identification Chart

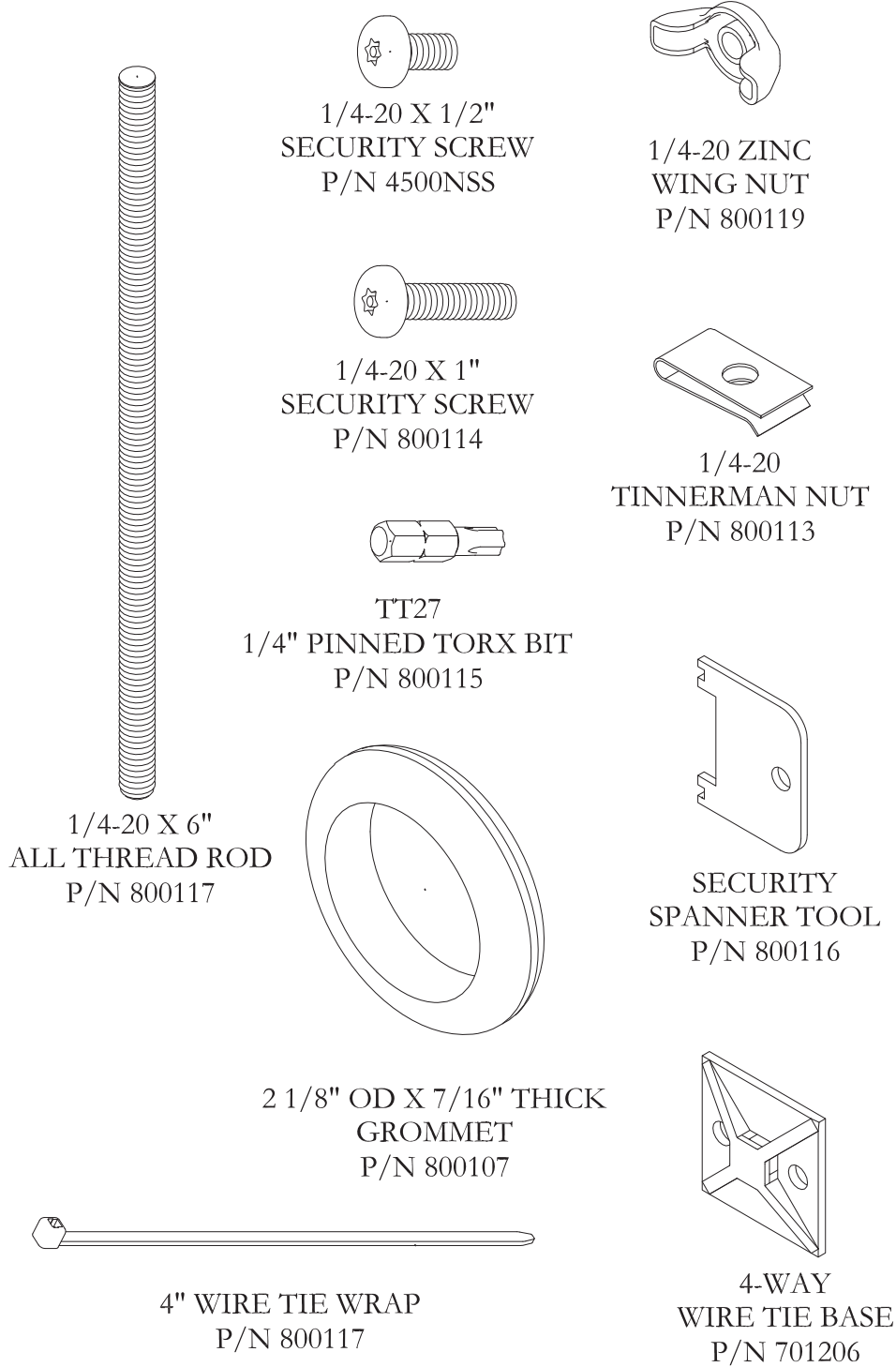

Installation Instructions

Step 1: Mounting Backplate

Parts supplied:

- Complete Unit (Pre-assembled)

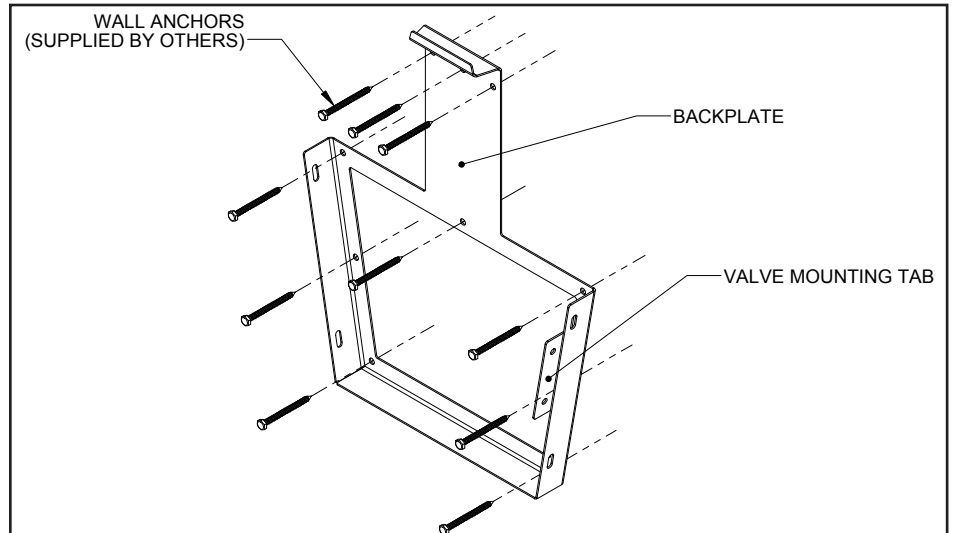

Note: Hardware for wall anchoring by others.

Note: Use anchors that are adequate for the type of wall: drywall, concrete, metal studs, wood studs, etc.

Note: Refer to rough-in drawing for backplate mounting hole locations to achieve 34" rim height.

- 1.) Remove shroud from pedestal backplate using security screws on sides.
- 2.) Measure and mark the vertical centerline of the washfountain on the wall. Mark a level line at the height prescribed by the rough-in drawing for the pedestal backplate center hole. Drill a hole for a wall anchor (supplied by others) at this height mark.
Make sure that the intended anchor locations will provide adequate backing to support the installed washfountain. If adequate backing does not exist, install appropriate support backing or relocate unit before proceeding with installation (backing provided by others).
- 3.) Mount the pedestal on the wall using a wall anchor through the backplate center hole and the first drilled hole. DO NOT TIGHTEN THIS FIRST WALL ANCHOR ALL THE WAY, as you may need to adjust the pedestal to ensure it is level.
- 4.) Make sure the pedestal is level and plumb against the wall, then mark and drill holes for the rest of the wall anchors as specified by the rough-in drawing.
- 5.) Ensure once more the pedestal is level, then secure it to the wall using the remaining anchors (supplied by others). Make sure all wall anchors are tight and secure against the pedestal backplate.

Note: Be sure backplate is level and plumb against the wall so that water in basin will drain correctly once assembly is completed.

Installation Instructions (cont.)

Step 2: Mounting Basin

Parts supplied:

- Solid Surface Basin
- Actuator Housing
- Pedestal Backplate

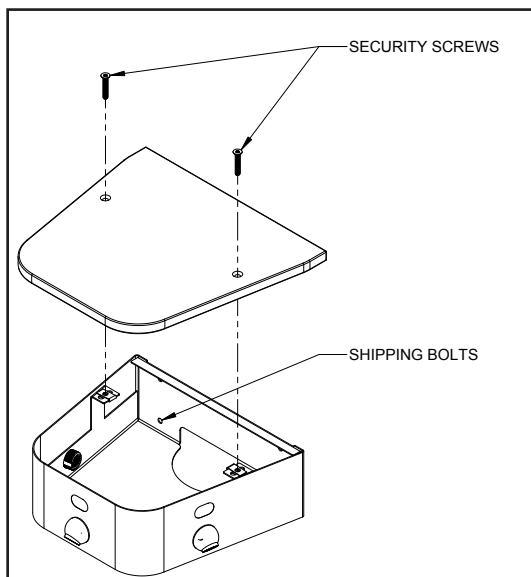

Removing the top cover.

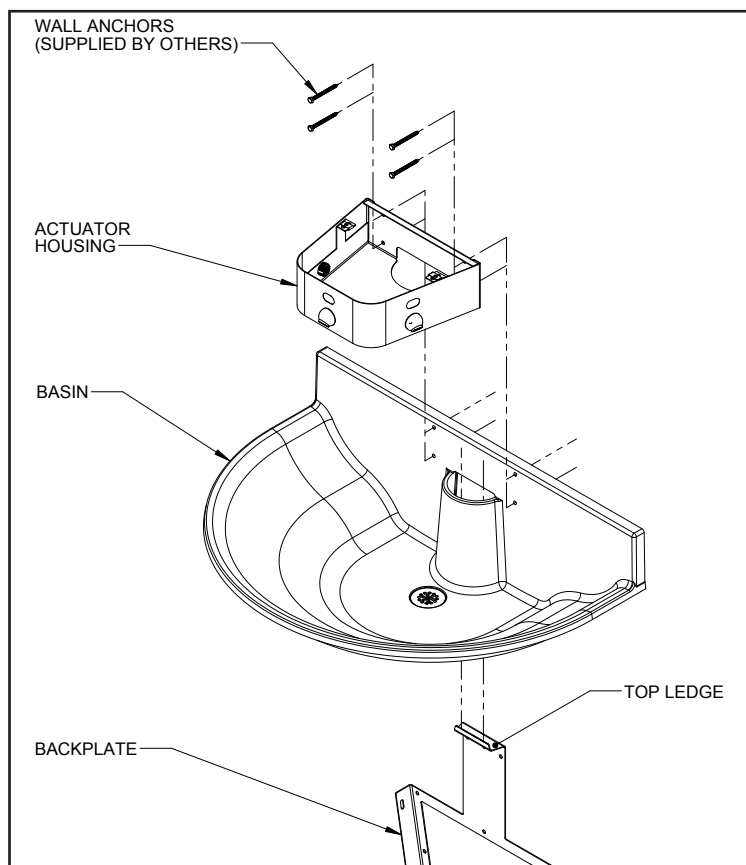

Mounting the basin and actuator housing to the backplate and wall.

- 1.) Remove top cover from the valve head kit by loosening the security screws as shown in the above-left diagram. Set the top cover, screws, and nuts aside.
- 2.) With the help of an assistant, place basin on top ledge of the pedestal assembly.
- 3.) Carefully mark mounting holes on wall through the basin, then remove the basin and drill the mounting holes.
- 4.) Replace the basin and valve head kit as shown in the above-right diagram.
- 5.) Fasten wall anchors (supplied by others) through the basin and valve head kit holes securely, **but DO NOT OVERTIGHTEN**; this can damage the solid surface basin and valve head kit.
- 6.) Secure the basin to the pedestal assembly by fastening the included screws up through the pedestal basin mounting ring into the threaded inserts on the bottom of the basin.

Note: BE SURE to use the screws included with the washfountain. Using longer screws than those provided can damage the solid surface basin.

Installation Instructions (cont.)

Step 3: Drain Assembly

Parts/Materials supplied:

- Solid surface basin
- Drain assembly (*see diagram*)

- 1.) As shown on the diagram, apply a small (approx. 1/4" dia. 6" long) strand of silicone caulk on the underside of the drain basket lip (supplied by others).
- 2.) Insert the drain basket down through the basin drain hole.
- 3.) Secure the drain basket in place by fitting the rubber and stainless steel washers onto the drain assembly from the underside of the basin. Tighten the locknut onto the drain basket assembly, sandwiching the washers between the basin and locknut.

Note: Over-tightening the locknut or security screw can damage the solid surface basin and/or drain assembly components.

- 4.) Secure the drain cover to the drain basket using the provided screw.

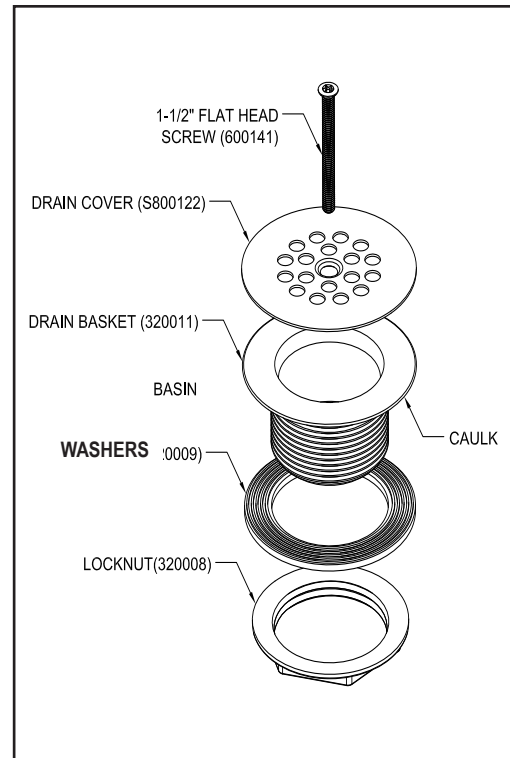

Installation Instructions (cont.)

Step 4A: Connections for Infrared/Piezo Actuators

Parts supplied:

- Valve Assembly (pre-installed)
- 3/8" x 4' Multi-Colored Water Lines
- Small Diameter Multi-Colored Pneumatic Tubing
- 1/4-20 x 1/2" security screws
- 1/4-20 tinnerman nuts

Note: Use wire tie mounts and wire ties to route and secure wiring. Wires are long enough to accommodate various routing paths. Longer tubes may need to be bundled with wire ties so they do not come in contact with sharp corners.

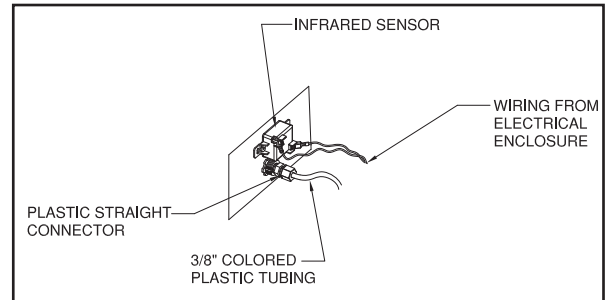

Infrared Sensor Actuator

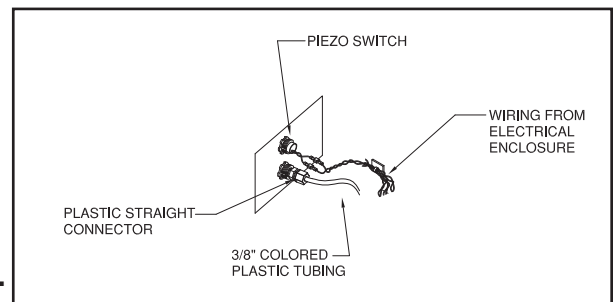

Piezo Push Button Actuator

- 1.) Locate the terminal block plate and attach to the pedestal using 1/4-20 x 1/2" security screws and tinnerman nuts.
- 2.) Locate the group of loose colored wires coming from the terminal block plate labeled "UPPER".
- 3.) Feed 2 like-colored wires into each of the actuator housing assemblies (either the Infrared or Piezo assemblies, whichever applies to the installation).
- 4.) Plug both like-colored wires into the actuator as shown above (either wire will work on each connector).
- 5.) Locate the 3/8" multi-colored water lines. Match the color of each water line with the corresponding color of wiring. Run the end of each water line up through the basin to the head kit. Match the color of each water line to the spray head assembly below each actuator. On each corresponding spray head, loosen the plastic nut on the plastic connector and firmly push the water line through the plastic nut into the fitting. Tighten the plastic nut to secure the water line to the spray head. Repeat for each remaining water line. (**see JACO Fitting Instructions on Page 19 for further detail).
- 6.) Once all water lines have been attached to their corresponding spray heads, on each corresponding manifolded valve assembly, loosen the plastic nut on the plastic connector and firmly push the water line through the plastic nut into the fitting. Tighten plastic nut to secure the water line to the valve assembly. Repeat for each water line.
- 7.) Connect each set of like-colored wires to each of the manifolded valves.

Installation Instructions (cont.)

Step 4B: Connections for Pneumatic Actuators

Parts supplied:

- Valve Assembly (pre-installed)
- 3/8" x 4' Multi-Colored Water Lines
- Small Diameter Multi-Colored Pneumatic Tubing
- 1/4-20 x 1/2" security screws
- 1/4-20 tinnerman nuts

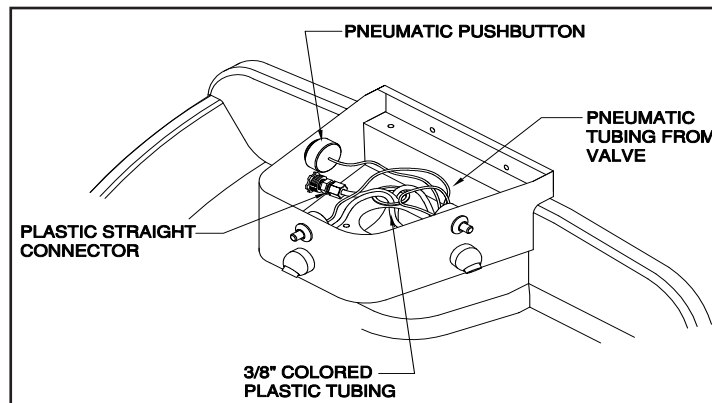

Pneumatic Push Button (Similar 3-station unit shown)

Note: Use wire tie mounts and wire ties to route and secure tubing. Longer tubes may need to be bundled with wire ties so that do not come in contact with sharp corners.

- 1.) Locate the small multi-colored pneumatic tubing. Feed each one into each of the actuator housing assemblies.
- 2.) Plug each tube onto the hose barb on the back of the pushbutton.
- 3.) Locate the 3/8" multi-colored water lines. Match the color of each water line with the corresponding color of tubing. Run the end of each water line up through the basin to the head kit. Match the color of each water line to the spray head assembly below each pushbutton actuator. On each corresponding spray head, loosen the plastic nut on the plastic connector and firmly push the water line through the plastic nut into the fitting. Tighten the plastic nut to secure the water line to the spray head. Repeat for each remaining water line. (**see JACO Fitting Instructions on Page 19 for further detail).
- 4.) Once all water lines have been attached to their corresponding spray heads, on each corresponding manifolded valve assembly, loosen the plastic nut on the plastic connector and firmly push the water line through the plastic nut into the fitting. Tighten plastic nut to secure the water line to the valve assembly. Repeat for each water line.
- 5.) Connect each set of like-colored tubing to each of manifolded valves.

Installation Instructions (cont.)

Step 5: Final Assembly

Parts supplied:

- Solid Surface Top Cover
- Pedestal Shroud
- Pedestal Lower Shroud (floor-mounted unit)
- 1/4-20 Tinnerman Nut
- 1/4-20 x 1" Security Screw
- 1/4-20 x 1-1/2" Flat Head Security Screws

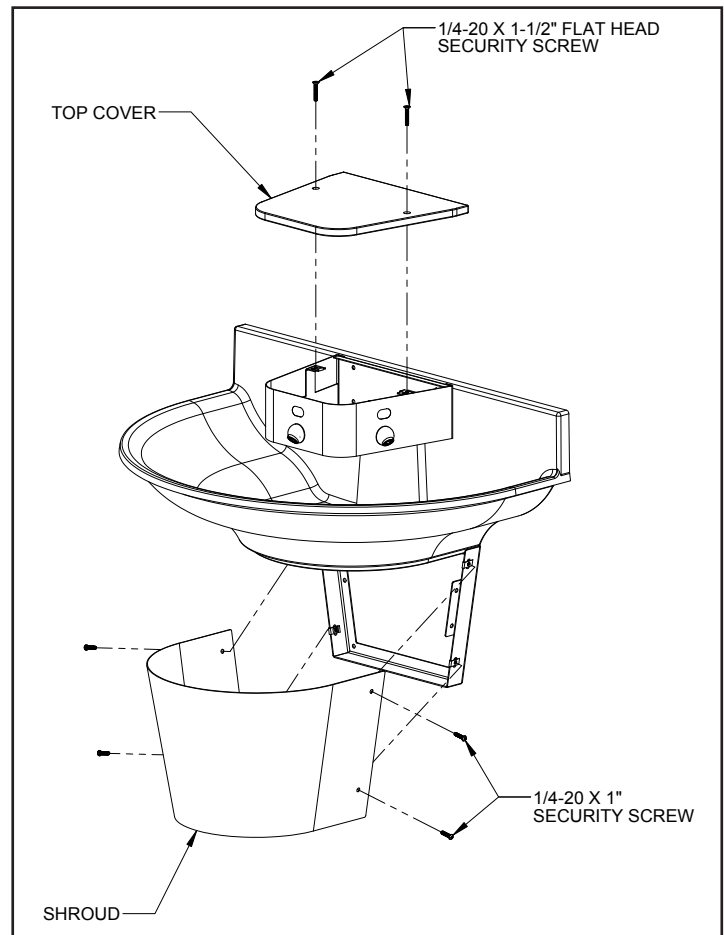

- 1.) Make all final plumbing connections to valve inlets using supplied flex hoses (flex hoses have shut-off valves attached that should be connected to the supply inlets).
- 2.) Once all of the connections in the actuator housings are complete, locate the transformer.

NOTE: PLUG-IN TRANSFORMER (IF NEEDED) MUST BE USED WITH A GROUND FAULT INTERRUPT (GFCI) RECEPTACLE TO HELP PREVENT POSSIBLE ELECTRICAL SHOCK.

- 3.) Test the system for leaks (both supply and waste).
- 4.) Using 1/4-20 x 1-1/2" flat head security screws, attach top cover to the actuator housing.
- 5.) Using 1/4-20 x 1" security screws, attach shroud to the backplate.
- 6.) If you have a floor-mounted unit, attach the lower shroud using 1/4-20 x 1" security screws.

JACO Fitting Instructions



Note: It is not necessary to disassemble this fitting for application. Merely insert tubing to stop and tighten seal.

1. Cut tubing end squarely and remove the internal burrs.
2. Insert the tubing through the back of the nut all the way through the nut assembly to the tube stop in the fitting body (see illustration). If the tubing does not enter the nut easily, loosen the nut one turn and reinsert the tubing all the way to the tube stop in the fitting body.
3. Turn the nut hand tight.
4. Wrench tighten the nut $1\frac{1}{2}$ - 2 turns.
5. All nuts must be retightened when the system reaches projected operating temperature.

Note: To ensure proper assembly, tubing MUST be fully inserted into the fitting body all the way to the tube stop.

Note: Squeaking sound when tightening nut is normal. For pipe threaded connections, Teflon tape must be used.

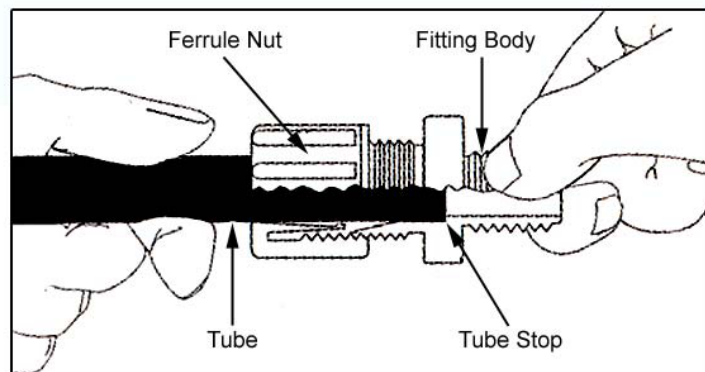
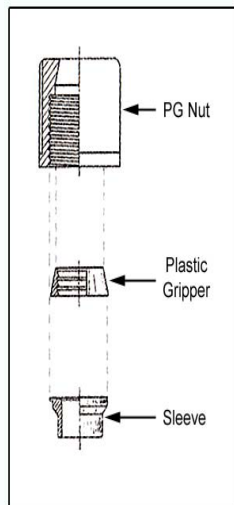

Mixing Valve Instructions

POWERS™

IS-P-e480

**HydroGuard® T/P Series e480
Lavatory Combination Valve**

Installation Instructions

To Install ■

NOTE: Installation should be in accordance with accepted plumbing practices. Flush all piping thoroughly before installation.

1. Locate a suitable place for the tempering valve. Valve should be accessible for service and adjustment and as close to the point-of-use as possible.
2. Connect hot and cold water to the supply valve using 1/2" NPT or 3/8" compression connections.
3. Connect outlet of tempering valve to fixture(s) using 1/2" NPT or 3/8" compression connections.
4. Turn on hot and cold water supplies. If any leaks are observed, tighten connections as necessary to stop leaks before proceeding.
5. Turn on fixture and allow water to flow for 2 minutes. Measure water temperature at outlet. If water is not at desired temperature, adjust as necessary.

Specifications ■

e480-00	1/2" NPT (Rough Bronze)
e480-01	1/2" NPT (Rough Chrome)
e480-10	3/8" Compression (Rough Bronze)
e480-11	3/8" Compression (Rough Chrome)
Capacity:	4.0 gpm (15.0 l/m)
Approach Temperature:	5°F (2.8°C) above set pt.
Max. Operating Pressure:	125psi (862 kpa)
Max. Static Pressure:	125psi (862 kpa)
Max. Hot Water Temperature:	180°F (82°C)
Temp. Adjustment Range:	
	ASSE Type T/P: 95 – 110°F (43-48°C)
	ASSE Type T: 80 – 120°F (27-49°C)
Minimum Flow:	0.5 gpm (2.2 l/m)
Checks:	Integral
Construction:	Cast Brass Body
Certified:	CSA B125
Listing	ASSE 1016-1996 (Type T/P)
	ASSE 1070

CALIFORNIA PROPOSITION 65 WARNING

WARNING: This product contains chemicals known to the State of California to cause cancer and birth defects or other reproductive harm. (California law requires this warning to be given to customers in the State of California.)
For more information: www.watts.com/prop65

Figure 1

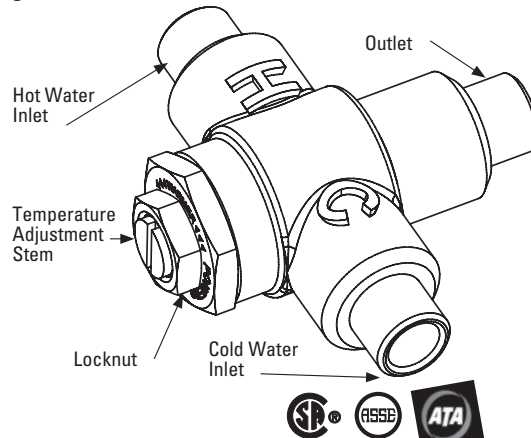
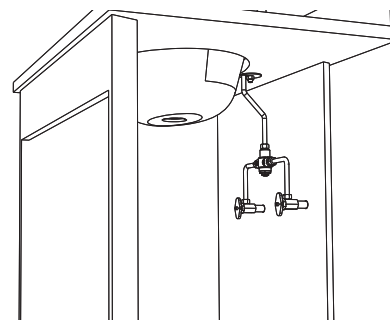

Figure 2: Typical Installation



Advanced Thermal Activation

To Adjust Temperature ■

1. Loosen locknut.
2. Turn on fixture and run water for at least two (2) minutes to allow supply temperature to stabilize.
3. Turn temperature stem counter-clockwise for hotter or clockwise for colder outlet temperature.
4. Tighten locknut to prevent accidental or unauthorized temperature adjustment.
5. Re-check outlet temperature.

Repair Kit ■

Motor Repair Kit.....480-270

Infrared Sensor Installation Instructions

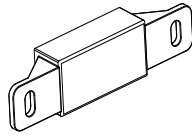

Willoughby Industries Infrared Lavatory Sensor Installation Instructions

DETECTION AND ACTIVATION

When the sensor detects a user, a slow flashing red light appears in the sensor window. After 1 to 2 seconds of detection, the light flashes rapidly and the sensor immediately activates the solenoid valve to begin water flow. The solenoid valve remains open as long as the user is detected. The solenoid valve turns off when the user is no longer detected. The sensor is set to activate the solenoid for a maximum of 30 seconds before automatically shutting off.

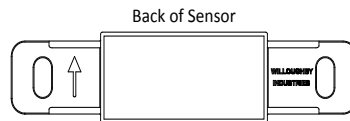

Figure 1

INSTALLATION AND REPLACEMENT

1. Disconnect 24Vac power at the transformer or fuse box.
2. Remove top cover to expose sensors.
3. Install new sensor. Make sure sensor arrow is pointing up. *See figure 1.*
4. Connect the red male power cable to the red female connector on the sensor. *See figure 2.*
5. Connect the black female solenoid cable to the black male connector on the sensor. *See figure 2.*
6. Replace top cover removed in step 2.
7. Reconnect power.

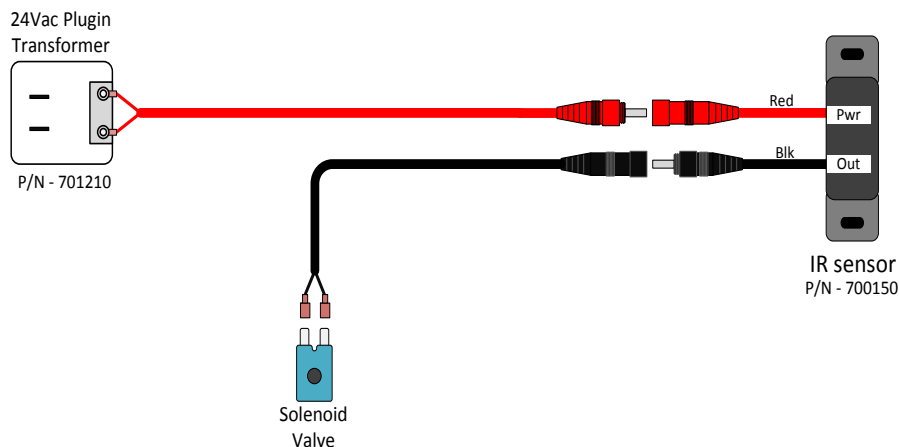
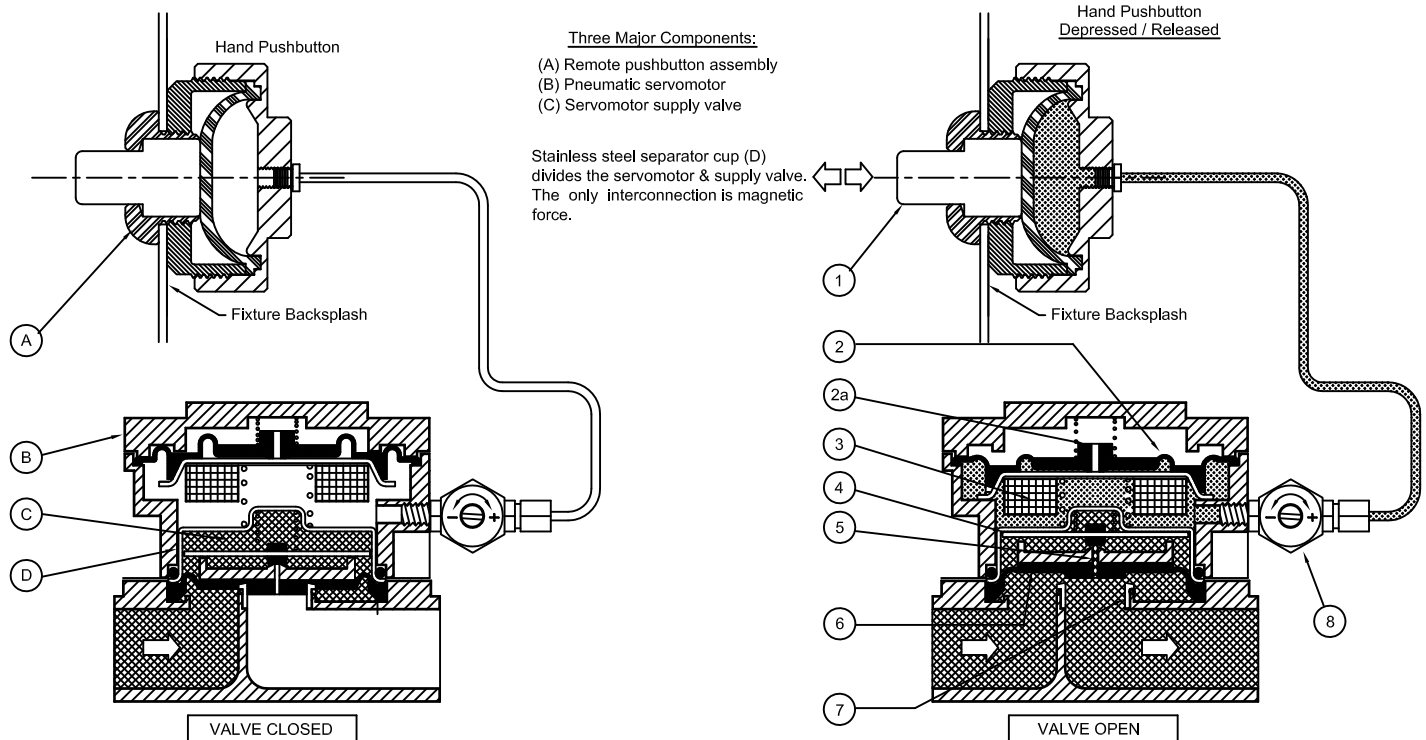

Figure 2

Pneumatic Valve Operation Details



Valve Closes: Air bleeds in through the timer (8) into the chamber below the actuating diaphragm (2). When the pressure in this chamber returns to normal, the diaphragm (2), and the magnet (3), are forced up. The pilot orifice plate (4) drops, covering the pilot orifice (5). Water pressure increases above the seat diaphragm (6), closing the diaphragm (6), against the seat (7).

Valve Opens: Depressing the button (1), forces air through the actuating diaphragm check valve (2a), and to atmosphere. Releasing the button (1), creates a vacuum below actuating diaphragm (2), and magnet (3). Diaphragm (2), and magnet (3), are forced down. Pilot orifice plate (4) is pulled up by magnet (3), opening the pilot orifice (5), bleeding off line pressure from above the seat diaphragm (6). Water pressure then lifts the seat diaphragm (6), off the seat (7), and opens the valve.

Liquid Soap Specification and Maintenance

(For models with “LSD” option only)

Liquid soap viscosity is measured in “cps” (centipoise). The liquid soap chosen to be used with Willoughby’s Liquid Soap Dispenser should be between 100cp and 2500cp.

The viscosity of the soap should be thin and free flowing.

Some soap types are available in a concentrate and must be diluted with water.

The pH (acidity) level should be in the range of 6.5 to 8.5.

Soap which is too acidic (pH less than 6.5) can corrode stainless steel and degrade rubber, plastic, or chrome-plated materials.

Soap that is outside the range of 6.5 - 8.5 might be harsh on the hands or skin.

(Generally, any quality soap meeting the viscosity and pH guidelines should work well.)

Recommended Maintenance Schedule

To maintain proper function, Willoughby’s Liquid Soap Dispenser should be cleaned periodically to remove soap residue. The Liquid Soap Spout should be soaked in hot water for a period of 30 minutes when cleaning is being performed. The soap tray should also be cleaned with hot water.

Care and Maintenance

Solid Surface Care

Aquasurf® surfaces may be easily cleaned using conventional cleaning agents such as an ammonia based liquid cleaner, (glass cleaner).

Dry stains on a matte finish can be removed with a 3M Scotch-Brite gray scouring pad or a mild abrasive cleaner.

Burns or scorches can be removed by sanding with coarse grit sandpaper followed by finer grit (220) sandpaper. Follow sanding with a 3M Scotch-Brite gray pad (or equivalent) to match finish of sanding area to surrounding area. A final buffing may be required on polished surfaces. Accidental nicks or chips can be repaired with special patch kits available in all Aquasurf® colors.

Avoid exposing Aquasurf® surfaces to strong chemicals such as acetone's; paint removers and sulfuric acid or hydrochloric chemical cleaners. Exposure to strong chemicals may result in permanent damage to Aquasurf® surfaces.

Stainless Steel Care

Stainless Steels are basically alloys of iron and chromium and are corrosion resistant. Stainless steel has a bright surface that is easy to clean and is free from oxides. Therefore, cleaning of stainless steel is relatively simple and easy if done on a regular basis.

Frequency of cleaning should depend on the rate at which the fixture becomes dirty. Remember that fresh (soft) deposits of all kinds are relatively easy to remove, while removing older (hard) deposits are much more difficult. Establish a cleaning SCHEDULE.

Routine cleaning should involve ordinary soap or detergent and water, applied with a sponge, brush or cloth. Baking soda, borax or any of several non-abrasive commercial cleansing agents can help hasten the cleaning action. After scrubbing, rinse THOROUGHLY and wipe dry.

DO NOT use common steel wool, scouring pads, scrapers, wire brushes, files or other steel tools to clean stainless steel. Such items will scratch the surface or leave small particles of iron imbedded in the surface, which will eventually rust and stain the surface - even appearing as if the stainless itself was rusting.

Certain chemical compounds, if used on stainless steel, can give the appearance of rust and if allowed to stand for long periods of time, can pit the surface of even stainless. Products containing hydrochloric acid, muriatic acid or potassium hydrochloride can ruin the surface.

Troubleshooting - Infrared Sensors

- I. Faucet does not function (red light does not appear when user steps in front of sensor)
 - A. No power to sensor. Make certain that power is on. Check transformer leads and connections. Repair or replace as necessary.
 - B. Willoughby 700150 IR Sensor not operating. Replace Willoughby 700150 IR Sensor.

- II. Faucet does not function (red light appears when user steps in front of sensor and solenoid does not click)
 - A. Debris in solenoid; disassemble, clean, and flush.
 - B. Solenoid not wired correctly; check solenoid connections.
 - C. Solenoid problem; replace solenoid.

- III. No water when activated (valve clicks)
 - A. Make certain that water is turned on.
 - B. Valve clogged. Clean or replace filter.

- IV. Very low flow or slow dribble
 - A. Check supply stop(s); open if closed.
 - B. Debris in filter; remove, clean, and reinstall.
 - C. Debris in aerator or spray head; remove, clean and reinstall.
 - D. Disassemble solenoid; clean and flush.

- V. Continues to run (with power on and red light flashing)
 - A. Non-permanent target in range after user leaves. Remove non-permanent target. If this target is a new permanent target (i.e., a new wall or partition), turn off 24 volt power for fifteen (15) seconds. Turn power back on and let the sensor complete start-up mode.
 - B. Sensor failure; replace sensor.

- VI. Continues to run (even with power disconnected)
 - A. Solenoid valve installed backwards.
 - B. Debris in solenoid, won't close properly; remove operator and clean. Reassemble in the same manner.

Troubleshooting - Electronic Valves

The two most common reasons an electronic valve does not operate properly are: (1) lack of power or (2) lack of water pressure. The following steps should be used as a guide in identifying the problem of a malfunctioning electronic valve.

- I. Lack of power
 - A. Verify that the 110V GFCI outlet has power
 - B. Check all connections to ensure they have been made correctly:
 1. Cable connecting the valve coil and the timer or IR sensor
 2. Cable connecting the timer and the pushbutton (Piezo only)
 3. Cable connecting the timing device and the 24VAC transformer
 4. The 24VAC transformer and the 110V GFCI outlet
 - C. If the valve is wired correctly, the solenoid will make a “click” sound indicating that the valve has been actuated. The electronic valve is actuated by either the piezo pushbutton or the triggering of the infrared sensor (see the Start-Up Instructions for Infrared Sensors in this manual).

- II. Lack of water pressure
 - A. Check the supply to the rough-ins
 - B. Make sure the screwdriver stops are in the open position
 - C. Water pressure needs to be above 35psi to operate the valve
 1. If the water supply pressure is above 35psi but not exiting the valve:
 - a. Clean any debris from the screen on the inlet side of the solenoid valve body
 - b. Remove the screws on the valve body and clean any debris from the diaphragm

After all of the above steps have been followed, if there is still no water coming out of the spray head, there may be a damaged or defective part (see installation notice in the beginning of this manual).

Troubleshooting - Pneumatic Valves

- I. Valve will not open or deliver water
 - A. Check the plastic tubing that runs from the pushbutton actuator to the pneumatic valve for air leaks.
 - B. Make sure the checkstop on the supply to the valve is fully open. Do not partially close the checkstop for any reason as it is not a throttling valve. The checkstop should be fully open (normal operation) or fully closed (when servicing the valve).
 - C. Close checkstop and then inspect the strainer in the supply line (installed after the checkstop) to make sure the strainer is not blocked or partially blocked, prohibiting water flow.

- II. Valve will not shut off
 - A. Separate valve motor from casting by removing the four (4) #8 screws.
 - B. Inspect the water diaphragm assembly to see if bypass hole in diaphragm is blocked. Remove any debris by blowing on diaphragm or using force of air. Do not use any tool (such as straight pin) to remove any debris. Enlarging the hole will shorten or make for erratic cycling.
 - C. Check the metering screw on the timer assembly to make sure the adjustment screw is not closed too tightly. To reset, back out adjustment screw (counterclockwise) about 1-1/2" turns, and adjust for the desired cycle.

- III. Valve continues to trickle or partially deliver water after cycle is over
 - A. Inspect seating area on valve base to make sure no debris, pitting, or scoring is present.
 - B. Clean seat or replace seat as necessary.
 - C. Inspect seating area of diaphragm for debris, clean as necessary. If debris has caused permanent indentations in the rubber, it may have to be replaced.

After all of the above steps have been followed, if there is still no water coming out of the spray head, there may be a damaged or defective part (see installation notice in the beginning of this manual).

Replacement Part Numbers

Table 1 – Replacement part numbers for general assembly:

DESCRIPTION	PART #
SOLID SURFACE BASIN	803603C-XX*
SOLID SURFACE TOP COVER	800333LP-XX*
PEDESTAL ASSEMBLY - WALL MOUNT	S600491
PEDESTAL ASSEMBLY - FLOOR MOUNT	S600492
HARDWARE KIT	800258
STND. SPRAY HEAD ASSEMBLY- WAF (AERATOR SPRAY HEAD, 0.5 GPM- #320157A) (SPRAY HEAD BASE, 45°- #800001)	320157A-ASMB

*XX REPRESENTS THE WASH FOUNTAIN COLOR

B = BONE
 BG = BLACK GRANITE
 GG = GREY GRANITE
 GW = GLACIER WHITE
 NB = NOCTURNAL BLUE
 RC = RED CORAL
 SG = SEA GREEN
 SS = SAND STONE
 WG = WHITE GRANITE

Table 2 – Replacement part numbers for models with Infrared Actuation:

DESCRIPTION	PART #
VALVE HEAD KIT - INFRARED	WAF3603-I
VALVE ASSEMBLY - ELECTRONIC	803106-3EW
POWER SUPPLY	700156-3
PLUG-IN TRANSFORMER	701210
INFRARED SENSOR	700150

Table 3 – Replacement part numbers for models with Piezo Actuation:

DESCRIPTION	PART #
VALVE HEAD KIT - PIEZO	WAF3603-E
VALVE ASSEMBLY - ELECTRONIC	803106-3EW
PUSHBUTTON - PIEZO	701179-C
POWER SUPPLY	800139A
PLUG-IN TRANSFORMER	701210
PNEUTRONIC TIMER	330043

Table 4 – Replacement part numbers for models with Pneumatic Actuation:

DESCRIPTION	PART #
VALVE HEAD KIT - PNEUMATIC	WAF3603-P
VALVE ASSEMBLY - PNEUMATIC	803106-3PW
PUSHBUTTON - PNEUMATIC	600307

DRAWING: General Dimensions

IN COMPLIANCE
 WITH A.D.A. 2010

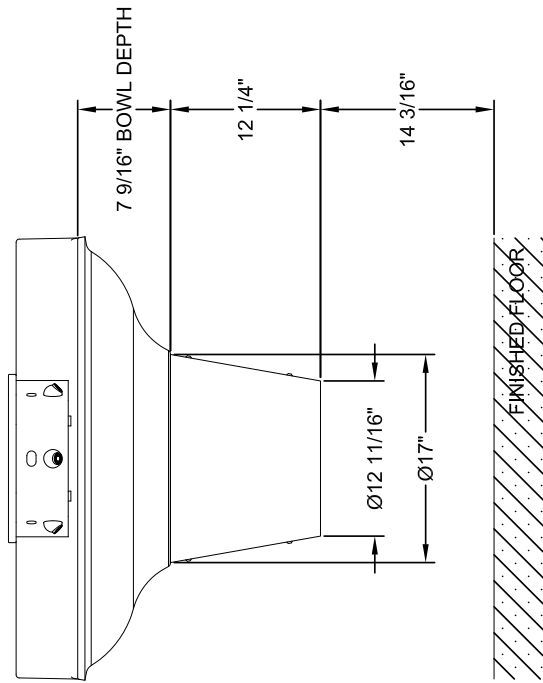
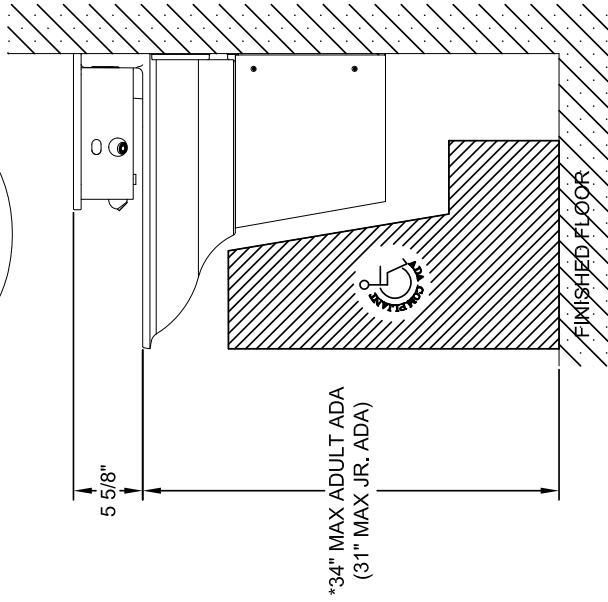
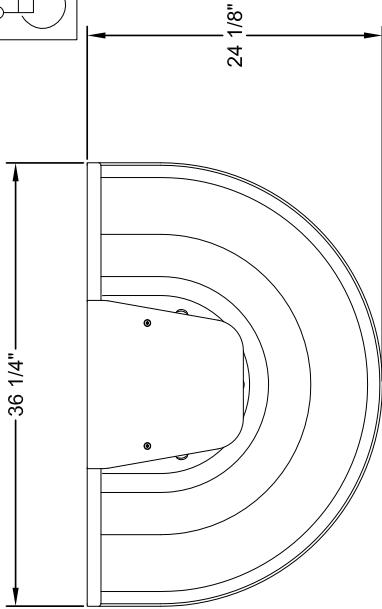
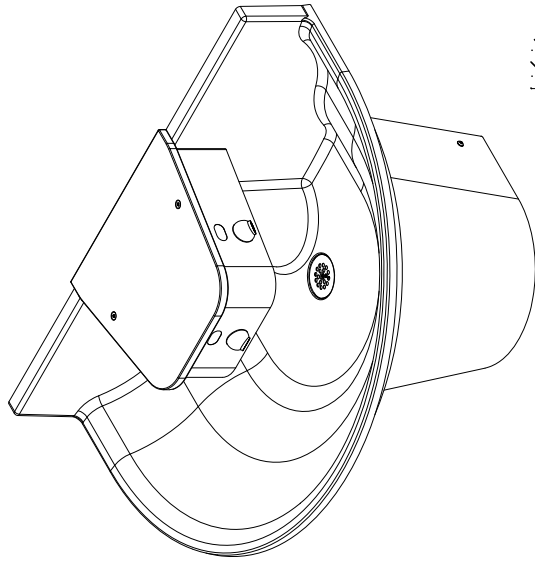

*NOTE: 34" RIM HEIGHT SHOWN, ADJUST DIMENSIONS ACCORDINGLY FOR ALTERNATE HEIGHTS

	Willoughby Industries Inc. Indianapolis, Indiana	TITLE / DESC.: WAF-3603-WA 36" SOLID SURFACE WASHFOUNTAIN - WALL MOUNT, 34" RIM HEIGHT	PART #: A3603-0001
	TOLERANCES EXCEPT AS NOTED 2 PLCS: ±0.05 3 PLCS: ±0.015 FINISHES: 1/32" ANGLE: 31°	MATL.: A	REVISION ORG.: JBU 1/31/02
			REV: MW 6/2/15
			F

DRAWING: Electronic Valve Detail

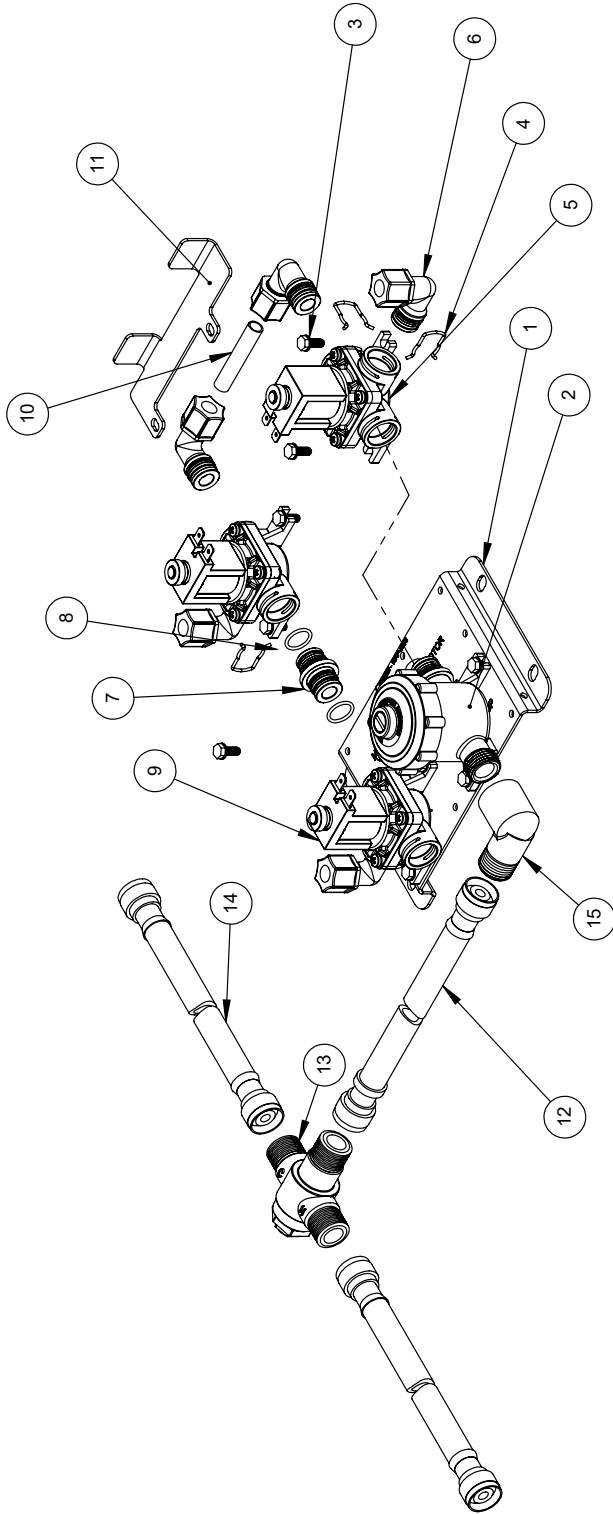

ITEM #	PART #	DESCRIPTION	QTY.
1	980502M	VALVE MOUNTING PLATE	1
2	980183	CHECKSTOP ASSEMBLY	1
3	800133	#10-16 SELF TAP TYPE B HEX HEAD SCREW	9
4	980140	SPRING CLIP, ROUND	8
5	980408	E1L VALVE ASSEMBLY	2
6	980600A	VALVE FITTING ASSEMBLY, 3/8" ELBOW	5
7	980197	PLASTIC VALVE COUPLING	1
8	980164	O-RING, #015	2
9	980408PR	E1L VALVE ASSEMBLY - RIGHT PLUGGED PORT	1
10	600523	TUBING, LOW DENSITY POLYETHYLENE, 3/8" OD X 1/4" ID	1
11	S301406	BRACKET, ELBOW SUPPORT	1
12	980506	6" FLEX HOSE, 1/2 F.I.P CONNECTION	1
13	700480ELF	MIXING VALVE, TMV, LEAD FREE, LF-E480	1
14	980520	20" FLEX HOSE, 1/2 F.I.P CONNECTION	2
15	320515	ELBOW, SCHD 80 PVC 1/2" FIP X MIP	1

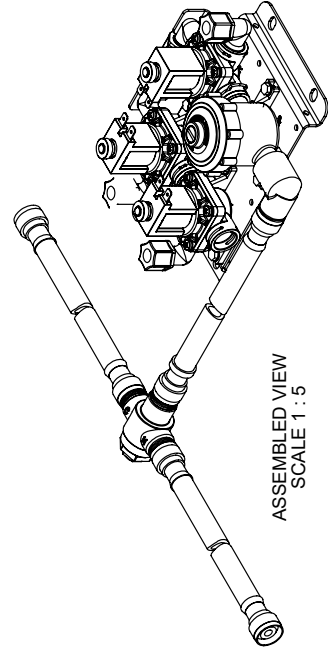

ASSEMBLED VIEW
SCALE 1 : 5

Willoughby Industries, Inc.		PART #:	
Indianapolis, Indiana		803106-3EW	
TOLERANCES EXCEPT AS NOTED	2 PLCS: #005 3 PLCS: #015 FRAG: #015	REVISION ORG.: TRB	9/10/13
SCALE: 1:4	REF:	REV: NAL	8/2/21
WILLOUGHBY		STANDARD SHEET: 1 OF 1	

DRAWING: Electronic Valve Detail

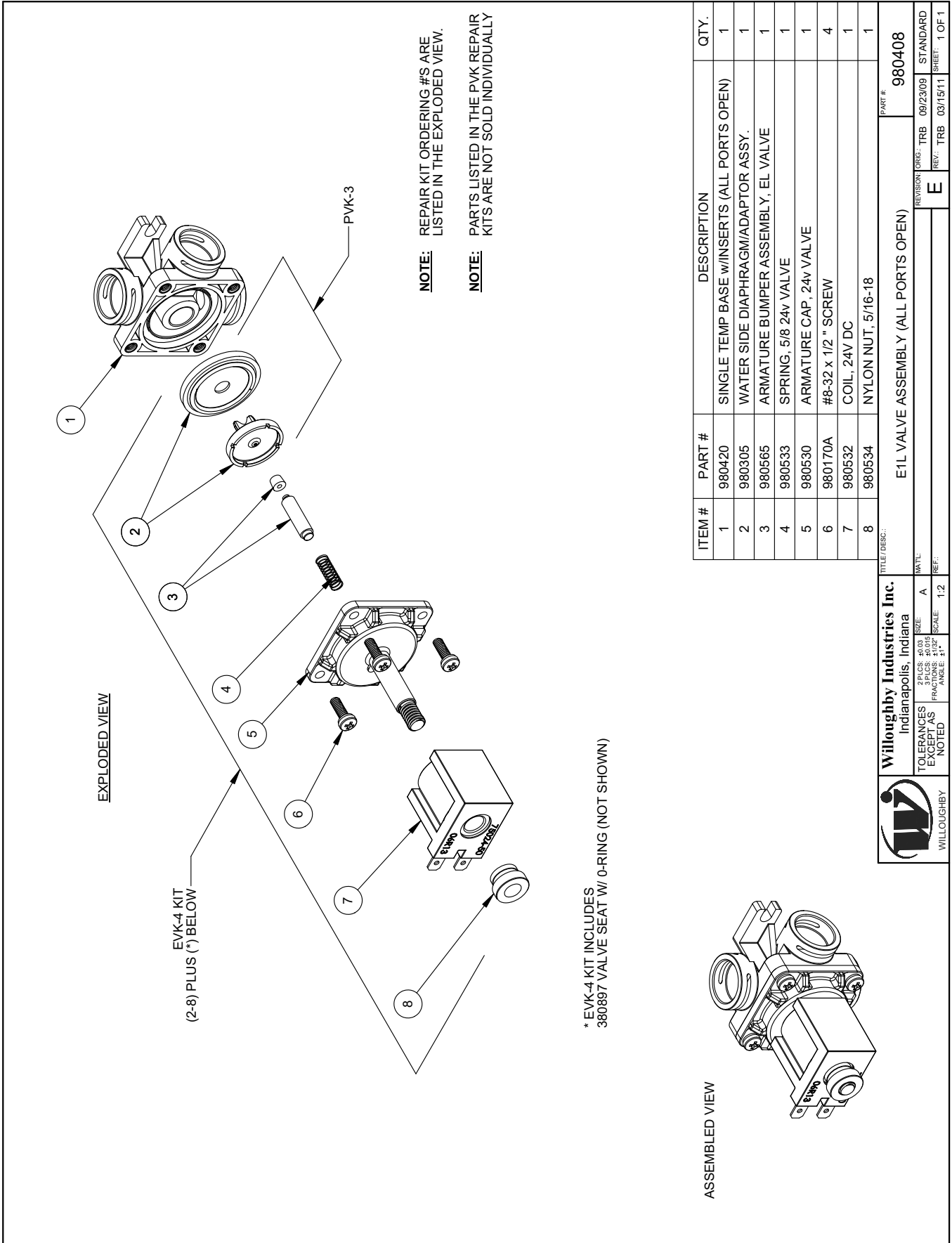

NOTE: REPAIR KIT ORDERING #S ARE LISTED IN THE EXPLODED VIEW.

NOTE: PARTS LISTED IN THE PVK REPAIR KITS ARE NOT SOLD INDIVIDUALLY

* EVK-4 KIT INCLUDES:
380897 VALVE SEAT W/ O-RING (NOT SHOWN)

ITEM #	PART #	DESCRIPTION	QTY.
1	980420	SINGLE TEMP BASE w/INSERTS (ALL PORTS OPEN)	1
2	980305	WATER SIDE DIAPHRAGM/ADAPTOR ASSY.	1
3	980565	ARMATURE BUMPER ASSEMBLY, EL VALVE	1
4	980533	SPRING, 5/8 24V VALVE	1
5	980530	ARMATURE CAP, 24V VALVE	1
6	980170A	#8-32 x 1/2 " SCREW	4
7	980532	COIL, 24V DC	1
8	980534	NYLON NUT, 5/16-18	1

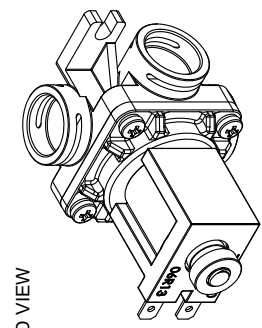

ASSEMBLED VIEW

Willoughby Industries Inc.
Indianapolis, Indiana

TOLERANCES EXCEPT AS NOTED

2 PLCS: 20/03 SIZE: A
FRACTIONS: 1/32 SCALE: 1:2
ANGLE: 31°

WILLOUGHBY

TITLE/DISC: E1L VALVE ASSEMBLY (ALL PORTS OPEN)

PART #: 980408

REVISION ORG: TRB 09/23/09 STANDARD
REV: TRB 03/15/11 SHEET: 1 OF 1

DRAWING: Pneumatic Valve Detail

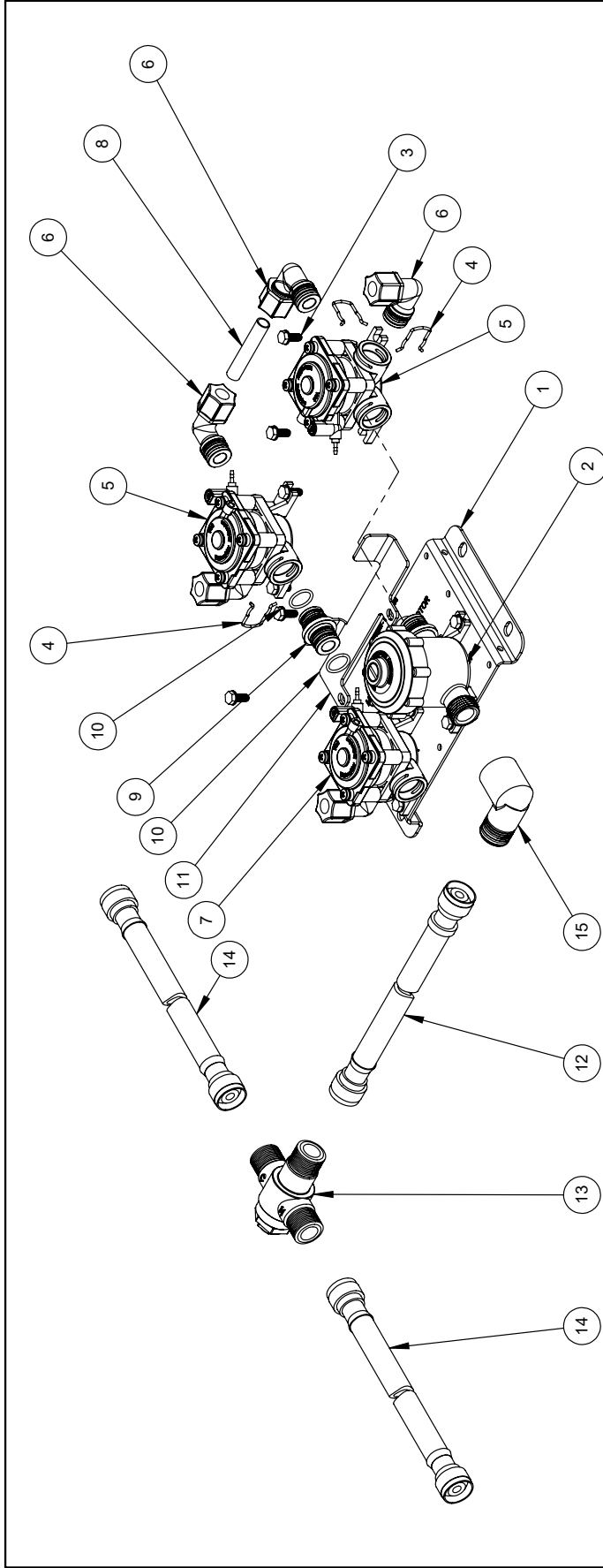

ITEM #	PART #	DESCRIPTION	QTY.
1	980502M	VALVE MOUNTING PLATE	1
2	980183	CHECKSTOP ASSEMBLY	1
3	800133	#10-16 SELF TAP TYPE B HEX HEAD SCREW	10
4	980140	SPRING CLIP, ROUND	8
5	980406R	PNEUMATIC METERING VALVE ASSEMBLY - RIGHT	2
6	980600A	VALVE FITTING ASSEMBLY, 3/8" ELBOW	5
7	980406PR	PNEUMATIC METERING VALVE ASSEMBLY - RIGHT PLUGGED PORT	1
8	600523	TUBING, LOW DENSITY POLYETHYLENE, 3/8" OD X 1/4" ID	1
9	980197	PLASTIC VALVE COUPLING	1
10	980164	O-RING, #015	2
11	S301406	BRACKET, ELBOW SUPPORT	1
12	980506	6" FLEX HOSE, 1/2 F.I.P. CONNECTION	1
13	700480ELF	MIXING VALVE, TMV, LEAD FREE, LF-E480	1
14	980520	20" FLEX HOSE, 1/2 F.I.P. CONNECTION	2
15	320515	ELBOW, SCHD 80 PVC 1/2" FIP X MIP	1

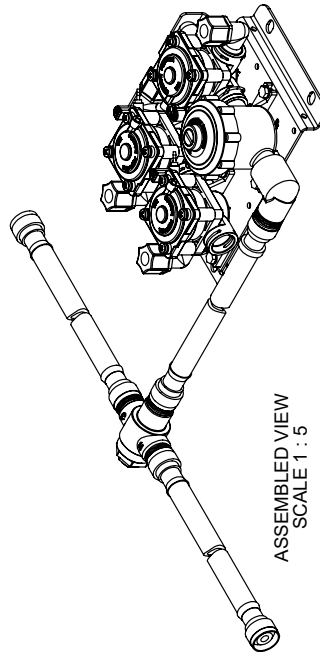

Willoughby Industries, Inc. Indianapolis, Indiana		PART # 803106-3PW
TOLERANCES UNLESS NOTED	DIMENSIONS IN INCHES FRACTIONS: 1/16"	REVISION ORIG. TRB 09/10/13 REV. NAL 06/18 STANDARD SHEET 1 OF 1
TOLEANCES UNLESS NOTED	DIMENSIONS IN INCHES FRACTIONS: 1/16"	TITLE (DESC.) VALVE ASSEMBLY, WASHFOUNT 3-STATION OFFSET (PNEUMATIC)
MATERIALS UNLESS NOTED	SCALE: 1:4	REF.

DRAWING: Pneumatic Valve Detail

ITEM #	PART #	DESCRIPTION	QTY.
1	980420	SINGLE TEMP BASE w/INSERTS (ALL PORTS OPEN)	1
2	980305	WATER SIDE DIAPHRAGM/ADAPTOR ASSY.	1
3	980310	WATER SIDE DISK ASSEMBLY	1
4	980136	SPRING, WATER SIDE DIAPHRAGM	1
5	980126	BARRIER CUP	1
6	980127	O-RING M1.5x32 BUNA-70	1
7	980410	METERING VALVE BODY ASSEMBLY	1
8	980135	SPRING, AIR SIDE MAGNET	1
9	980405	METERING VALVE MAGNET/CUP ASSEMBLY	1
10	980130	DIAPHRAGM, AIR SIDE, PNEUMATIC METERING VALVE	1
11	980134	AIR SIDE SPRING	1
12	380801M	AIR SIDE TOP COVER	1
13	980001A	#8-32 x 1 1/4" SCREW	4

NOTE: PARTS LISTED IN THE PVK REPAIR KITS ARE NOT SOLD INDIVIDUALLY

NOTE: REPAIR KIT ORDERING #'S ARE LISTED IN THE EXPLODED VIEW.

NOTE: PVK-1M, PVK-2, & PVK-3 PARTS ARE AVAILABLE IN KIT FORM ONLY.

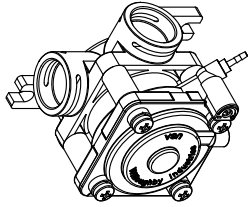

ASSEMBLED VIEW

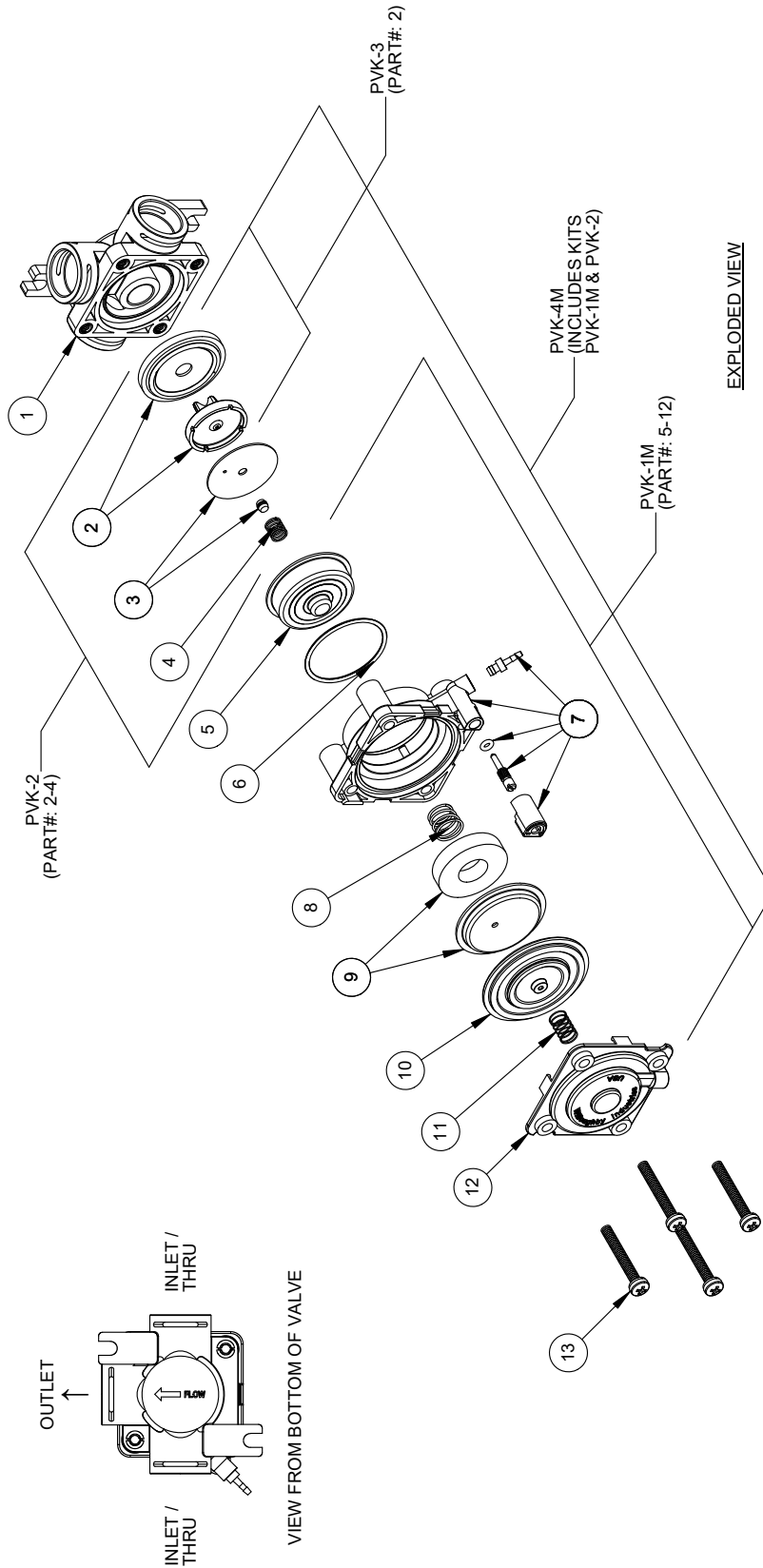

EXPLODED VIEW

Willoughby Industries Inc. Indianapolis, Indiana		TITLE / DESC: PNEUMATIC METERING VALVE ASSEMBLY - (RIGHT)		PART #: 980406R	
TOLERANCES EXCEPT AS NOTED		3 PLS: #0.01 FRACTIONS: 1/32"		REVISION / DRS: TRB 10/18/12	
WILLOUGHBY		SCALE: 1:2.5		REV: MW 8/31/16	
		MATERIAL: A		STANDARD SHEET: 1 OF 1	

DRAWING: Pushbutton Detail

PIEZO HEAD KIT DETAIL

✓	WIRE TERMINATOR	INV. #
	BARE STRIPPED WIRE	701179
	1/4" FEMALE SPADE CONNECTION	701179-C

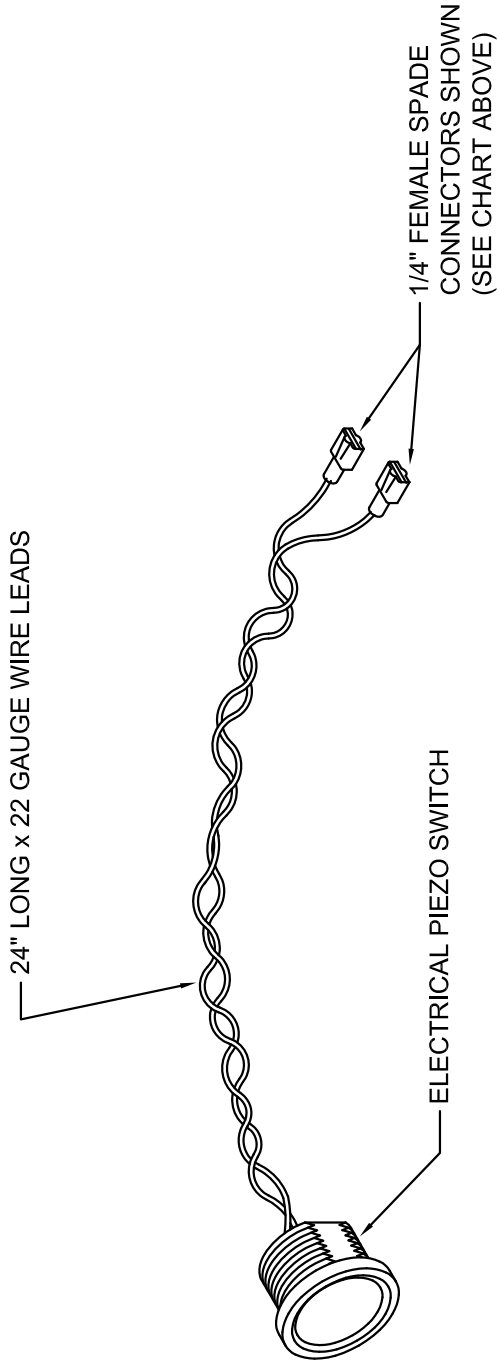

PIEZO SWITCH SPECIFICATIONS

PIEZO SWITCH HOUSING:

- MATERIAL: STAINLESS STEEL
- MOUNTING GEOMETRY: DOUBLE 'D' HOUSING
- SUPPLIED WITH NUT FOR MOUNTING
- 2 FT. LEADS INTEGRAL TO SWITCH (EXTENSION CABLES CAN BE SPECIAL ORDERED)
- EXTERNAL HOUSING OF SWITCH ELECTRICALLY ISOLATED FROM CIRCUITRY OF SWITCH

OPERATIONAL RATINGS:

- ACTUATION FORCE: LESS THAN 5 LBS.
- MAXIMUM VOLTAGE: 36 VOLTS AC/DC
- MAXIMUM AMPERAGE: 100 MA

DRAWING: Push Button Detail

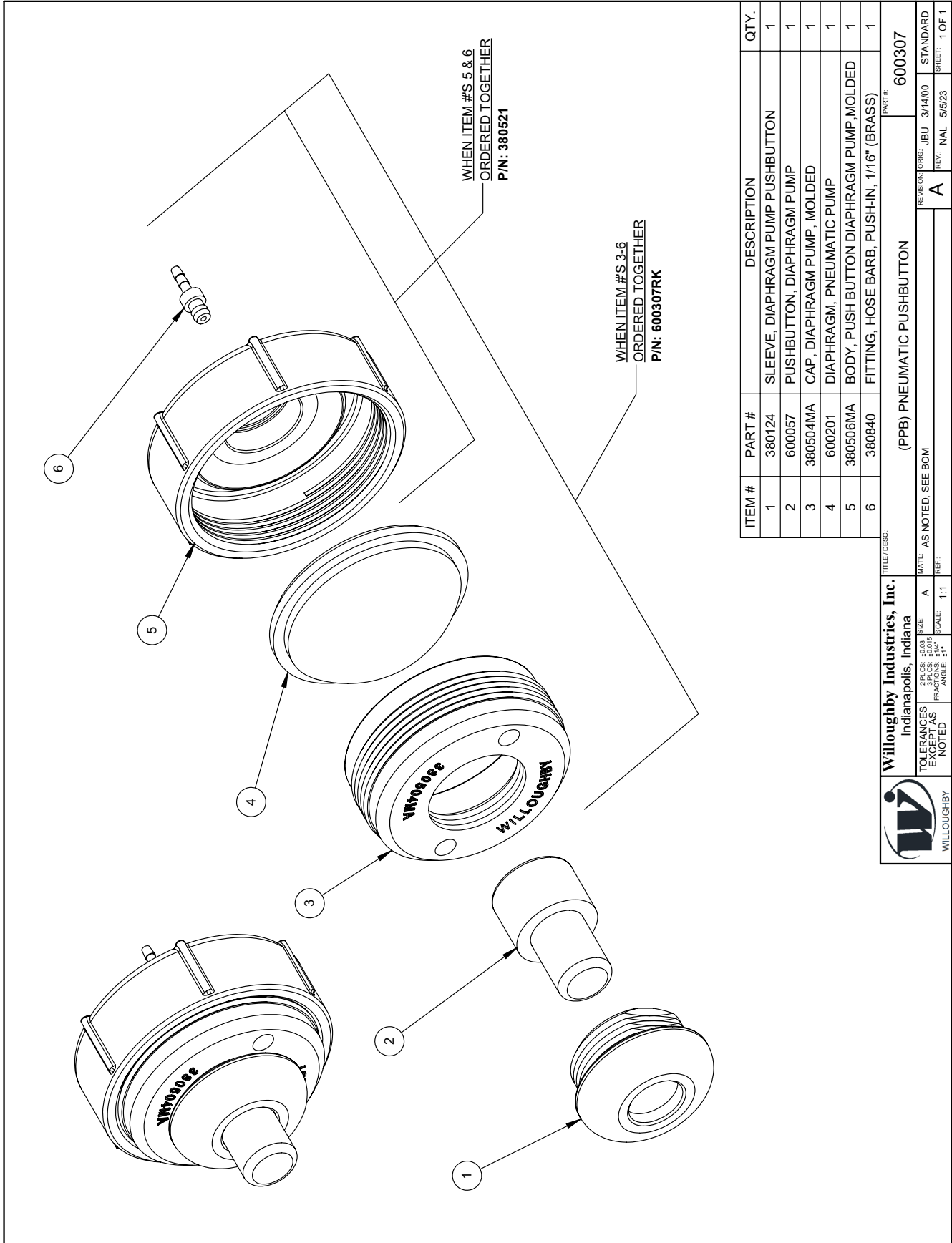

ITEM #	PART #	DESCRIPTION	QTY.
1	380124	SLEEVE, DIAPHRAGM PUMP PUSHBUTTON	1
2	600057	PUSHBUTTON, DIAPHRAGM PUMP	1
3	380504MA	CAP, DIAPHRAGM PUMP, MOLDED	1
4	600201	DIAPHRAGM, PNEUMATIC PUMP	1
5	380506MA	BODY, PUSH BUTTON DIAPHRAGM PUMP, MOLDED	1
6	380840	FITTING, HOSE BARB, PUSH-IN, 1/16" (BRASS)	1

Willoughby Industries, Inc.
Indianapolis, Indiana

TOLERANCES EXCEPT AS NOTED
FRACTIONS: 1/16"
SCALE: 1:1
ANGLE: 1°

2 PLCS: ±0.03
3 PLCS: ±0.05
4 PLCS: ±0.07

MATL: A
REV: A
AS NOTED, SEE BOM

TITLE/DESC: (PPB) PNEUMATIC PUSHBUTTON
PART #: 600307

REVISION ORG: JBU 3/14/00
STANDARD

REV: NAL 5/5/23
SHEET: 1 OF 1

WILLOUGHBY

DRAWING: Spray Head Detail

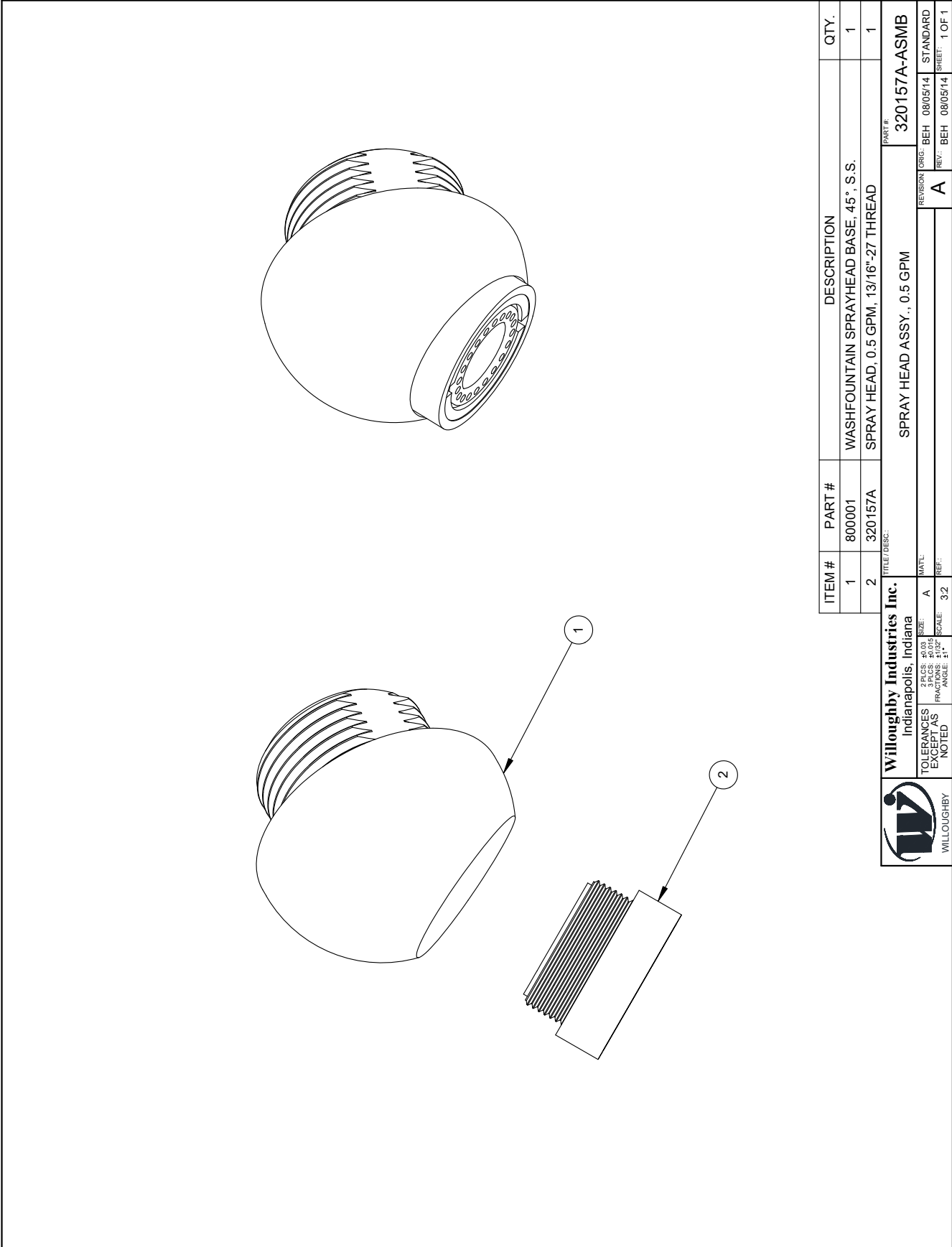

ITEM #	PART #	DESCRIPTION	QTY.
1	800001	WASHFOUNTAIN SPRAYHEAD BASE, 45°, S.S.	1
2	320157A	SPRAY HEAD, 0.5 GPM, 13/16"-27 THREAD	1

Willoughby Industries Inc.
Indianapolis, Indiana

2 PLS: ±0.03
3 PLS: ±0.015
FRONT VIEW
ANGLE: 1°

TOLERANCES EXCEPT AS NOTED

SCALE: 3/2

MATL: A
REV: REF:

REVISION DRES: A
BEH 08/05/14
REV: BEH 08/05/14

PART #: 320157A-ASMIB
STANDARD SHEET: 1 OF 1

WILLOUGHBY

DRAWING: Liquid Soap Dispenser Detail

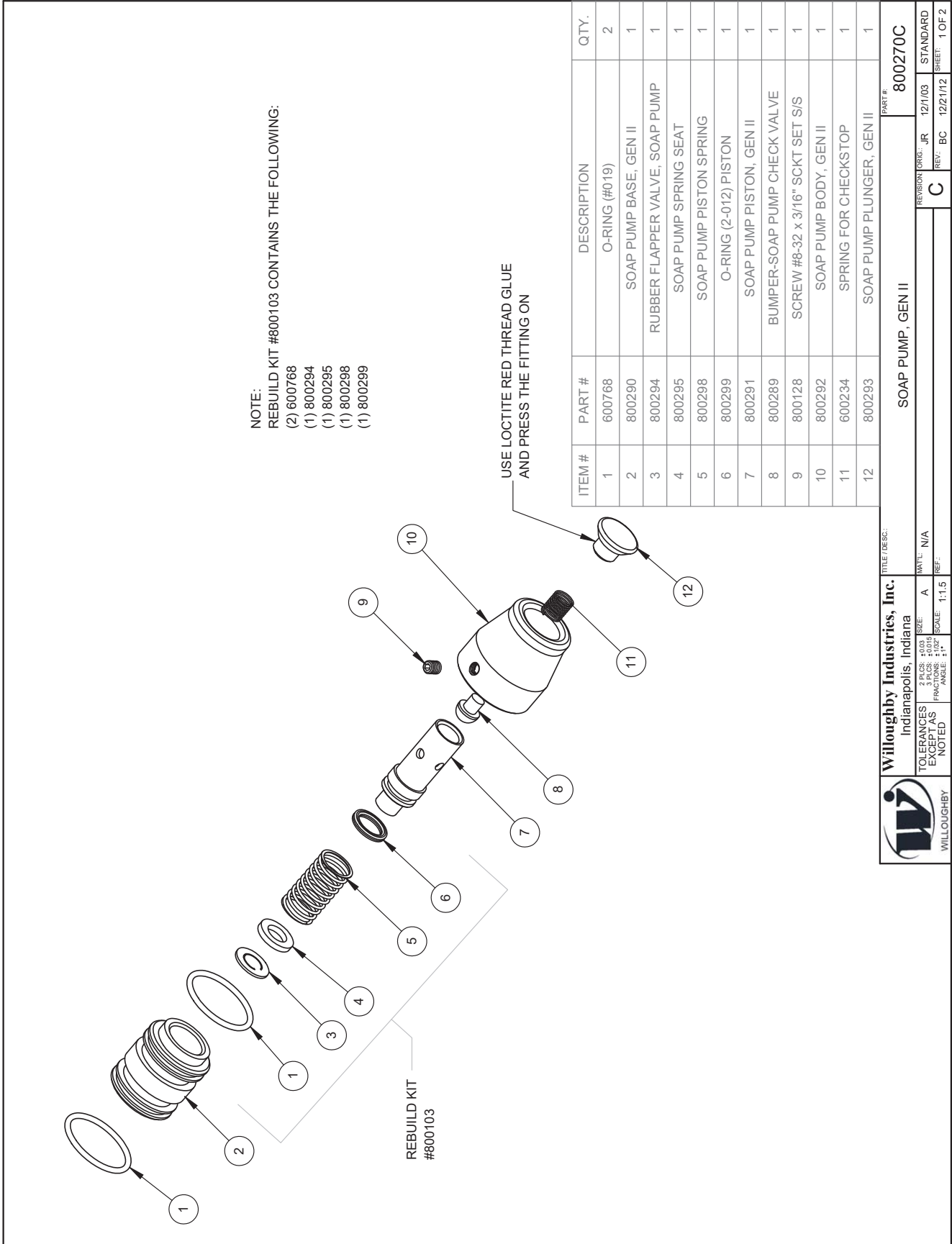

Willoughby Industries, Inc.
Indianapolis, Indiana

TOLERANCES EXCEPT AS NOTED
FRAGILE NOTED

SCALE: 1:1.5

DATE: 12/1/03
REV: JR
REV: BC

STANDARD SHEET: 1 OF 2

PART #: 800270C
SOAP PUMP, GEN II

Warranty

Aquasurf® Solid Surface Products are a homogeneous blend of resins, mineral filler and colorant manufactured for panels, molded and/or shaped products and components. Aquasurf® Solid Surface products provide a luxurious appearance with the durability of stain proof, impact resistant, burn resistant material with ease of maintenance and cleaning.

Willoughby Industries, Inc. warrants to commercial and institutional purchasers only that each unit will be free from defects in workmanship and materials under normal use and service upon the following terms and conditions. The period during which Aquasurf® components are warranted as follows:

1. Aquasurf® solid surface components are warranted for 2 years from date of shipment.
2. All other components warranted for 1 year from date of shipment.

This warranty does not cover installation or any other labor charges and does not apply to any components damaged by accident, abuse, improper installation or improper maintenance. This warranty does not cover any installation that did not comply with national, state and local building, plumbing or electrical codes. The warranty is limited to replacing or repairing at Willoughbys option, transportation charges prepaid by the purchaser, any Aquasurf® component or part which upon our inspection shall be deemed as defective within the limitations of this warranty. The replacement or repair of defective units as stated in this warranty shall constitute the sole remedy of the purchaser and the sole liability of Willoughby Industries, Inc. Willoughby Industries, Inc. shall not otherwise be liable under any indirect damages caused by defects in the repair or replacement thereof.

This warranty only extends to commercial and institutional purchasers and does not extend to any others, including consumer customers of commercial institutional purchasers. This warranty is in lieu of all other warranties, expressed or implied, including implied warranty of merchantability or fitness or a particular purpose or otherwise.