

Installation & Operation Manual

WAF-3606-FLR-FO Series

AquaFount® 36" 360° Solid Surface Washfountain Pneumatic Foot Control

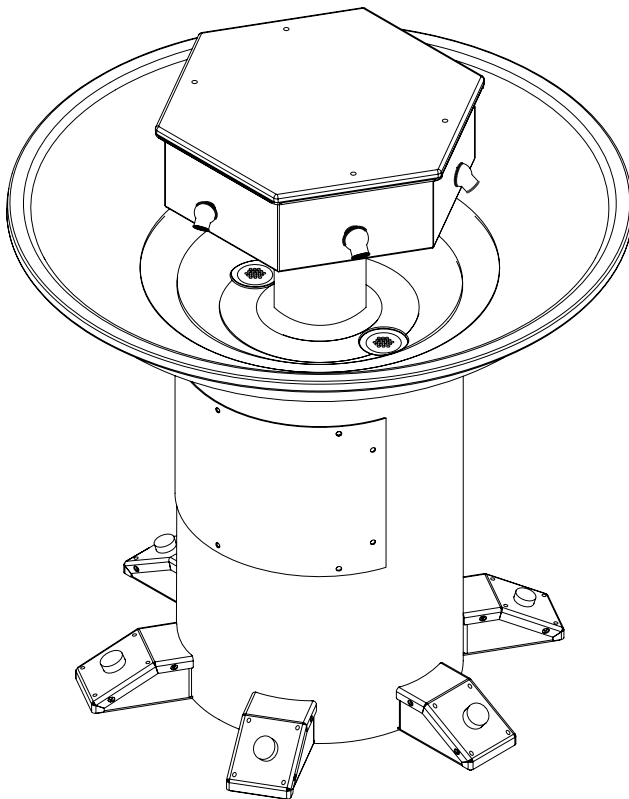

WAF-3606-FLR-FO

Table of Contents

Pre-Installation Information.....	3
Physical / Rough-in Dimensions.....	4
Required Installation Supplies	5
Parts List	6
Exploded-view Drawing.....	7
Hardware Identification	8
Installation Instructions	
Step 1: Pedestal Mounting.....	9
Step 2: Valving and Basin Assembly.....	10
Step 3: Drain Assembly	11
Step 4: Connections for Pneumatic Foot Control Actuators	12
Step 5: Final Assembly	13
JACO Fitting Instruction.....	14
Adjustable Mixing Valve Installation	15
Self-closing Pneumatic Valve	
Operation Details	16
Operation and Maintenance	17
Liquid Soap Specification and Maintenance.....	18
Care and Maintenance	19
Troubleshooting	
Self-closing Pneumatic Valves.....	20
Drawings.....	
General Dimensions and Rough-in	21
Valve Details	22
Miscellaneous Details.....	24
Warranty.....	27



Willoughby Industries, Inc.

5105 West 78th Street

Indianapolis, IN 46268

Toll Free: (800) 428-4065

Local: (317) 875-0830

Fax: (317) 875-0837

www.willoughby-ind.com

WILLOUGHBY

Rev. 9/2025

MADE IN THE U.S.A.



(Page intentionally left blank)

Pre-Installation Information

Installation notice!

Check Rough-In location **PRIOR** to installation

Flush lines thoroughly **PRIOR** to hook-up

When installing the **Willoughby Industries' WAF-3606 Series** washfountain system:

Before Step 1 of the installation instructions, ensure that rough-ins are in the correct location.

The valve assembly, including the spray head, **MUST NOT BE** connected until *after* all lines have been flushed to remove the small particles of debris that are inherent with new construction projects and all chemicals that are used in flushing are purged from the system.

Chemicals used in flushing plumbing systems can attack the internal components of the valve and spray head and severely damage them, so any flushing of the system must be followed by a full flushing with pure water to clear any harsh chemicals remaining in the system. Debris in the system if allowed to enter the valve assembly and spray head can cause poor performance or outright failure.

Again **DO NOT** attempt to connect the valve assembly and spray head until *after* all flushing is complete and pure water is the only media that will be passing through the system. Damage to the valve assembly or spray head caused by harsh chemicals or debris will not be covered by the manufacturer's warranty.

Installation notice!

Check Rough-In location **PRIOR** to installation

Flush lines thoroughly **PRIOR** to hook-up

Physical / Rough-in Dimensions- WAF-3606-FLR-FO

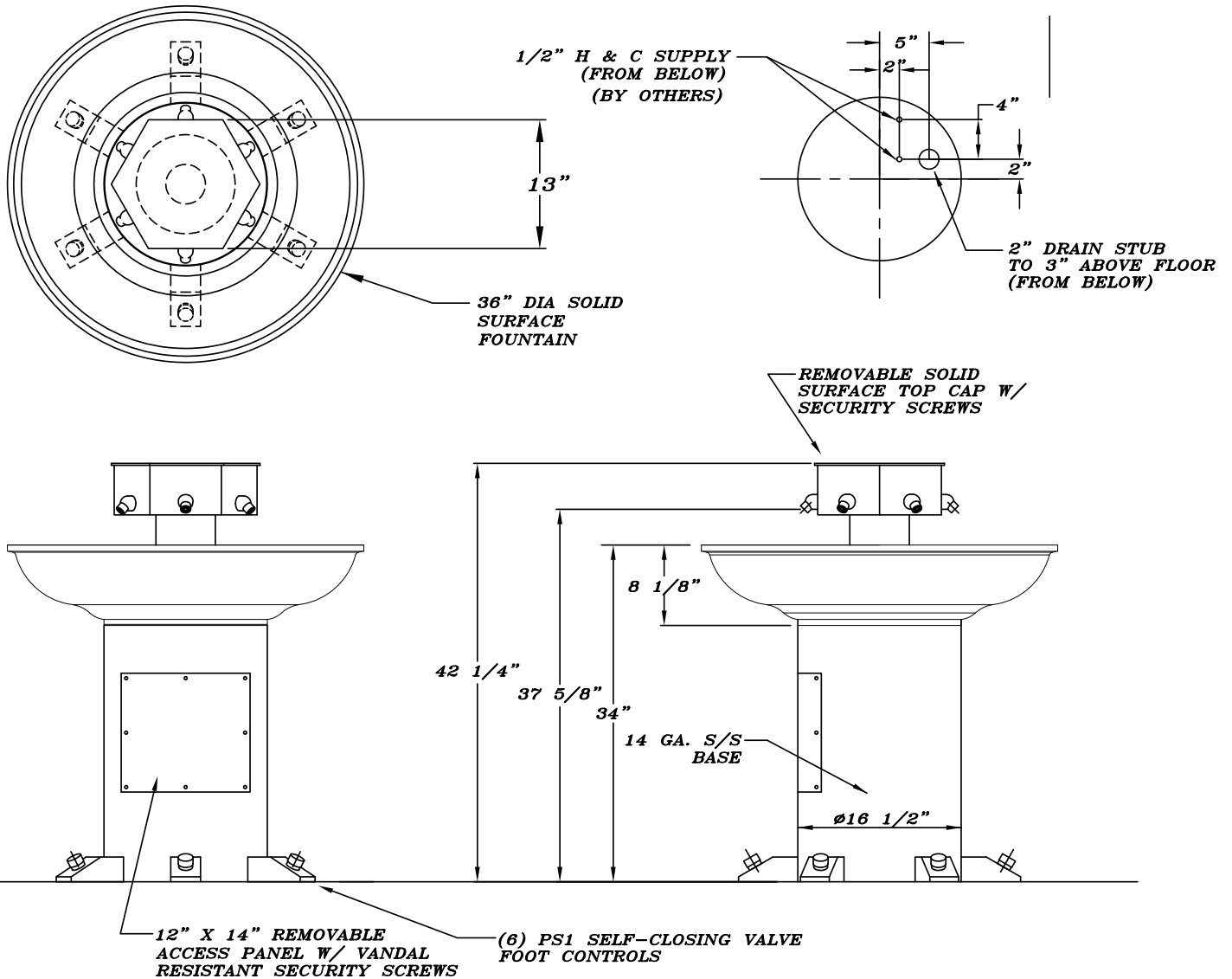

Required Installation Supplies

- Proper mounting hardware
- Hardware for waste outlet connections
- Gasket for waste outlet connection
- Shims (for installation if necessary)
- Supply piping
- Silicone caulk

WARNING: Willoughby Industries does not assume any responsibility for personal injury or damage to equipment due to an improperly installed WAF-3606 Series washfountain.

Parts List

ITEM #	DESCRIPTION	PART NUMBER (P/N) - 6-STATION
1	36" FULL-ROUND BASIN - SOLID SURFACE	803606C-XX*
2	TOP COVER - SOLID SURFACE	802020-XX*
3	DRAIN ASSEMBLY (WAF)	380281
4	ACTUATOR HOUSING / VALVE HEAD KIT - SELF-CLOSING PNEUMATIC	N/A
5	SELF-CLOSING PNEUMATIC VALVE ASSEMBLY	803105-6SW
6	PEDESTAL (FLOOR-MOUNT)	N/A
7	ACCESS PANEL	S600215
NOT SHOWN	STND. SPRAY HEAD ASSEMBLY- WAF (AERATOR SPRAY HEAD, 0.5 GPM- #320157A) (SPRAY HEAD BASE, 45*- #800001)	320157A-ASMB
	HARDWARE KIT	800258
	ACTUATOR PALM PUSHBUTTON	600311
	CHECKSTOP ASSEMBLY	980183
	STAINLESS STEEL FLEX HOSE (6")	980506
	STAINLESS STEEL FLEX HOSE (20")	980520
	POWERS HYDROGUARD T/P (LFe480)	700480ELF
	LIQUID SOAP SYSTEM	LSD6B
POWER SUPPLY	800137B	

*XX REPRESENTS THE WASH FOUNTAIN COLOR

- WHITE GRANITE=WG
- SAND STONE=SS
- GRAY GRANITE=GG
- BLACK GRANITE=BG
- SEA GREEN=SG
- NOCTURNAL BLUE=NB
- RED CORAL=RC
- GLACIER WHITE=GW
- BONE=B

Exploded-view Drawing

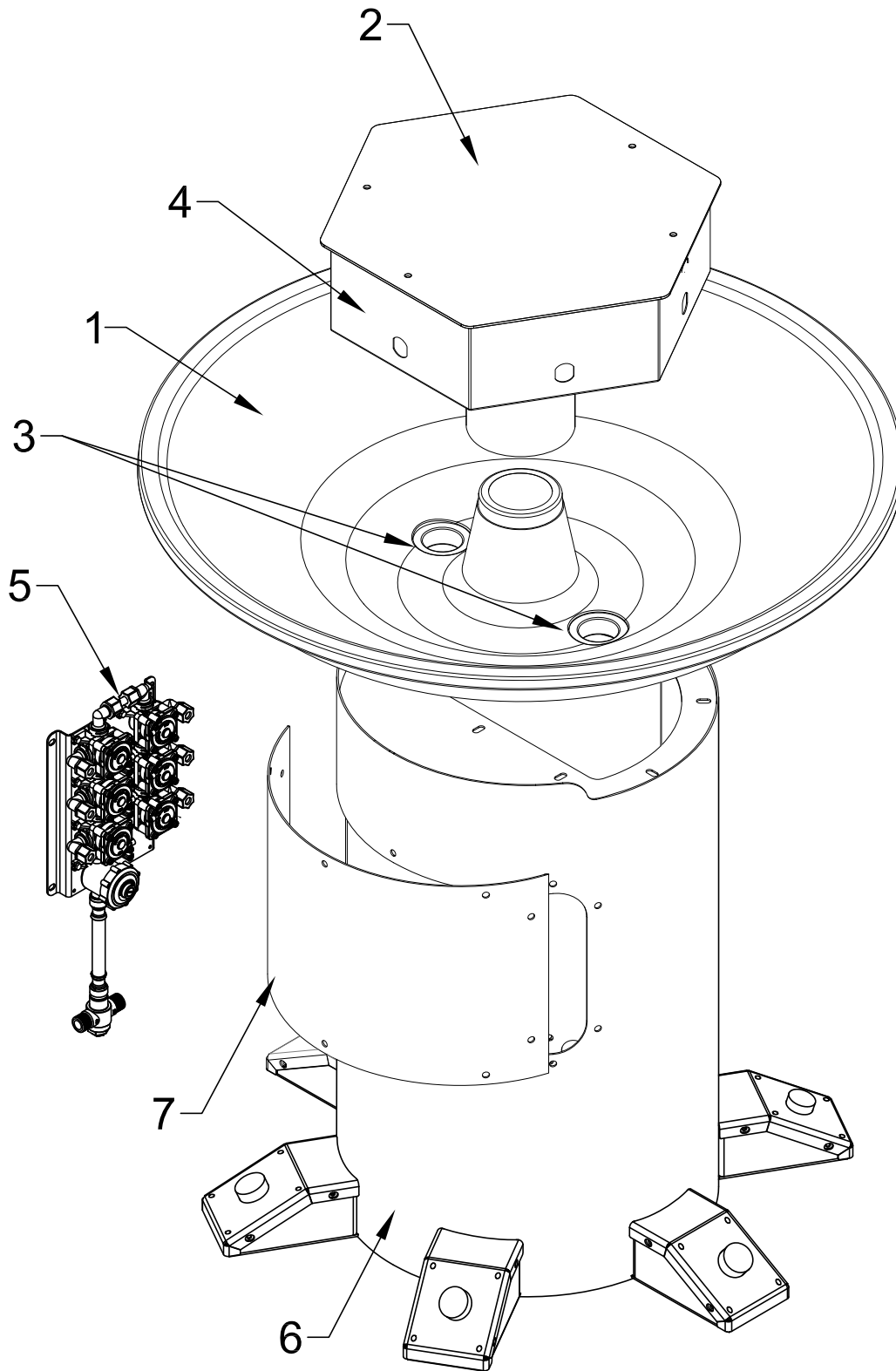

Hardware Identification

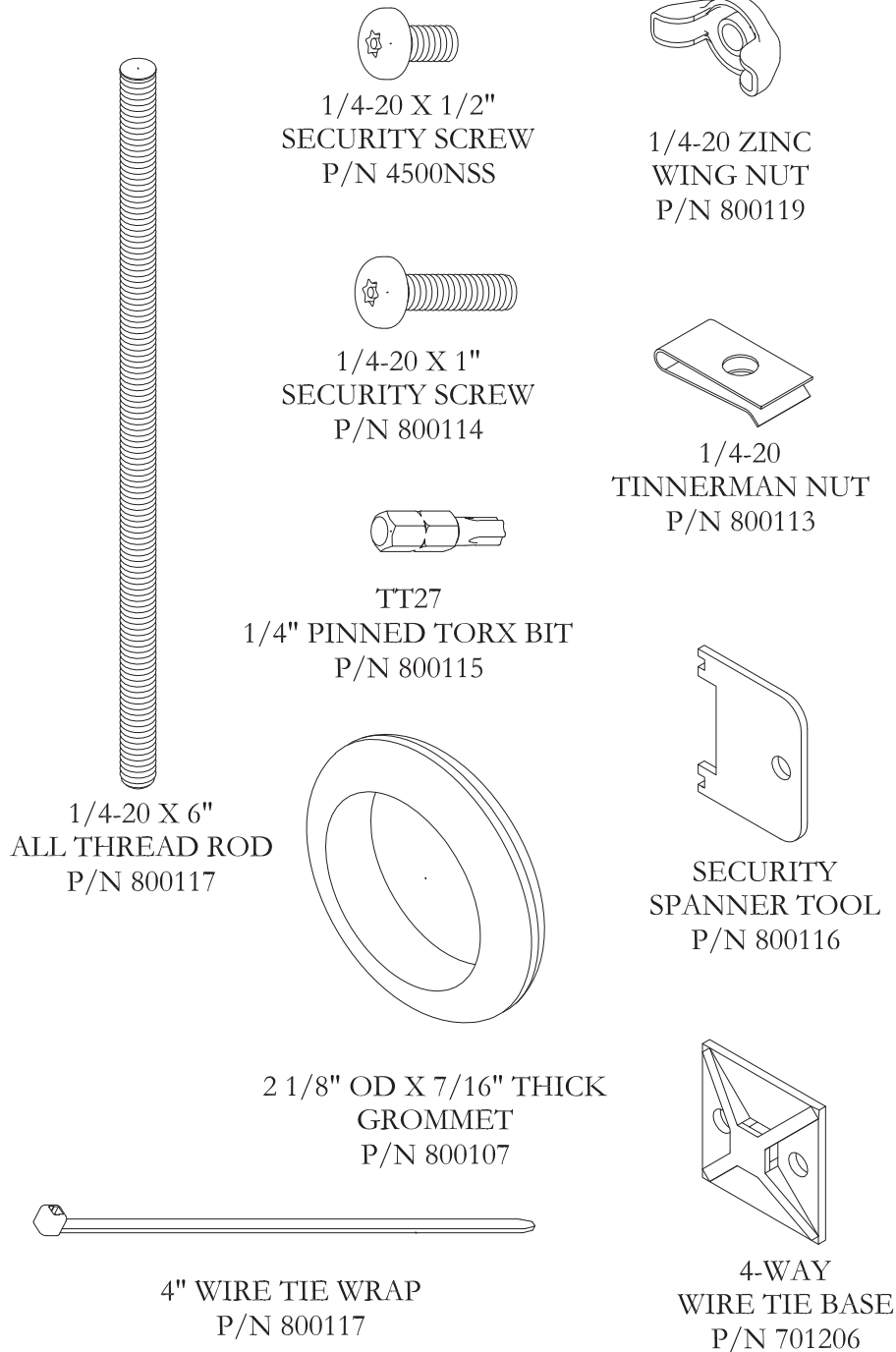

Installation Instructions

Step 1: Pedestal Mounting

Parts supplied:

- Pedestal base assembly

Note: Hardware for floor anchoring by others

- 1.) Unpack pedestal and inspect parts.
- 2.) Place pedestal at the desired position and mark anchor holes (anchors by others). *Make sure that the intended anchor locations will provide adequate backing to support the installed washfountain. If adequate backing does not exist, install appropriate support backing or relocate unit before proceeding with installation* (backing provided by others).
- 3.) Secure the pedestal to the floor using anchors that are adequate for the type of floor.

Installation Instructions (cont.)

Step 2: Valving and Basin Assembly

Parts supplied:

- Washfountain wash basin
- Pedestal base assembly
- Actuator housing assembly
- 1/4"-20 X 1/2" security screws

Caution: *Do not leave bowl on the pedestal unsupported, as it may fall and cause damage or personal injury.*

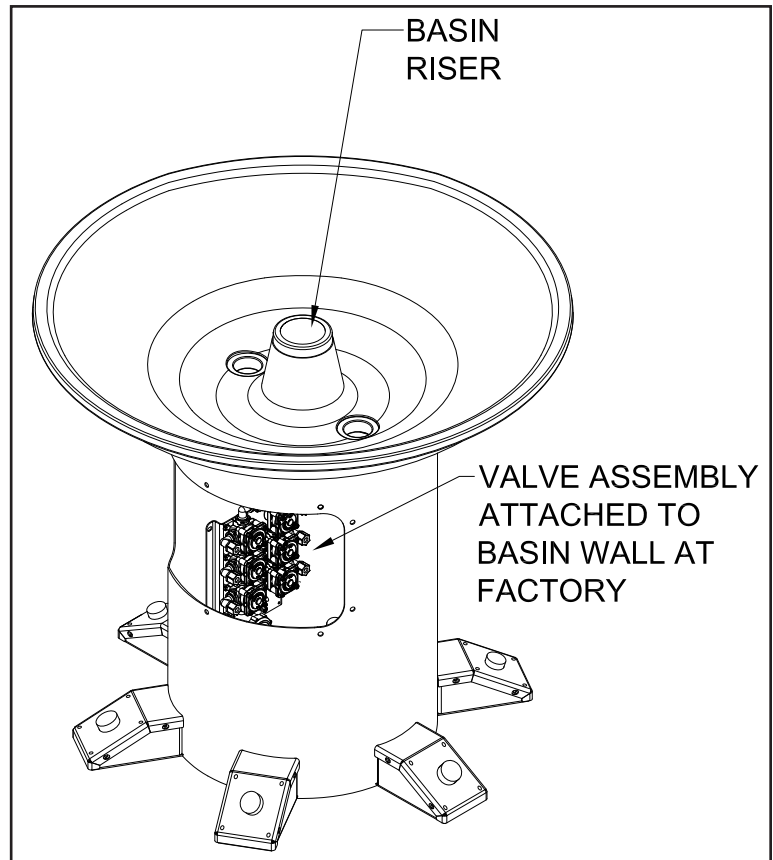

- 1.) With the help of an assistant, place the basin on top of the pedestal aligning the threaded inserts in the bottom with the holes in the top support ring. Secure with security screws.

Note: BE SURE to use the security screws included with the washfountain. Using longer screws than those provided can damage the solid surface basin.

- 2.) Place the head assembly over the center of the basin riser aligning the holes with threaded inserts. Secure with security screws, but DO NOT OVERTIGHTEN; this can damage the solid surface basin and actuator housing.
- 3.) The wash basin is ready for plumbing installation.

Installation Instructions (cont.)

Step 3: Drain Assembly

Parts/Materials supplied:

- Solid surface basin
- Drain assembly (*see diagram*)

- 1.) As shown on the diagram, apply a small (approx. 1/4" dia. 6" long) strand of silicone caulk on the underside of the drain basket lip (supplied by others).
 - 2.) Insert the drain basket down through the basin drain hole.
 - 3.) Secure the drain basket in place by fitting the rubber and stainless steel washers onto the drain assembly from the underside of the basin. Tighten the locknut onto the drain basket assembly, sandwiching the washers between the basin and locknut.
- Note: Over-tightening the locknut or security screw can damage the solid surface basin and/or drain assembly components.**
- 4.) Secure the drain cover to the drain basket using the provided screw.

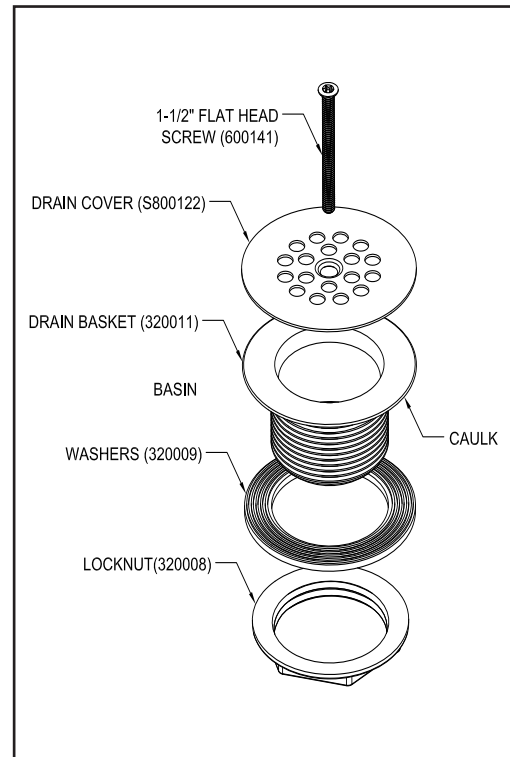

Installation Instructions (cont.)

Step 4: Connections for Pneumatic Foot Control Actuators

Parts supplied:

- Valve Assembly (pre-installed)
- 3/8" x 4' Multi-Colored Water Lines
- Small Diameter Multi-Colored Pneumatic Tubing
- 1/4-20 x 1/2" security screws
- 1/4-20 tinnerman nuts

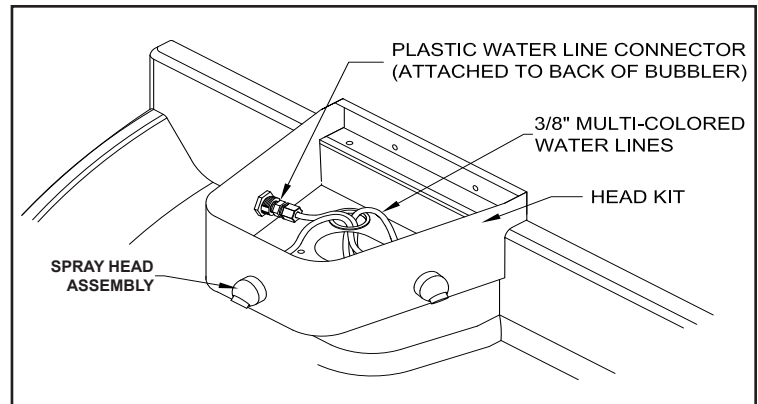

Pneumatic Foot Control head kit (3-station unit shown)

Note: Use wire tie mounts and wire ties to route and secure tubing. Longer tubes may need to be bundled with wire ties so that they do not come in contact with sharp corners.

- 1.) Locate the multi-colored pneumatic tubing. Feed each tube to the access hole of each foot control actuator housing on the bottom of the pedestal.
- 2.) Plug one end of each pneumatic tube onto the hose barb on the back of its corresponding foot control pushbutton diaphragm pump (*see DRAWING: Pushbutton Detail on Page 24). Run each tube up to the manifolded valve assemblies. Plug each tube's other end onto the hose barb of its corresponding valve assembly. Repeat process for each pneumatic tube.
- 3.) Locate the 3/8" multi-colored water lines. Match the color of each water line with the corresponding color of pneumatic tubing. On each corresponding valve assembly, loosen the plastic nut on the plastic connector and firmly push the water line through the plastic nut into the fitting. Tighten plastic nut to secure the water line to the valve assembly. (**see JACO Fitting Instructions on Page 14 for further detail). Repeat for each water line.
- 4.) Once all water lines have been attached to their corresponding valve assemblies, run the other end of each water line up through the basin to the head kit. Match the color of each water line to the spray head assembly above each foot control actuator. On each corresponding spray head, loosen the plastic nut on the plastic connector and firmly push the water line through the plastic nut into the fitting. Tighten the plastic nut to secure the water line to the spray head. Repeat for each remaining water line.

Installation Instructions (cont.)

Step 5: Final Assembly

Parts supplied:

- Solid surface cover
- Front panel
- Spacer tray
- 1/4"-20 tinnerman nuts
- 1/4"-20 X 1" security screws
- 1/4-20 X1" flat head security screws
- 1/4"-20 hex couplings

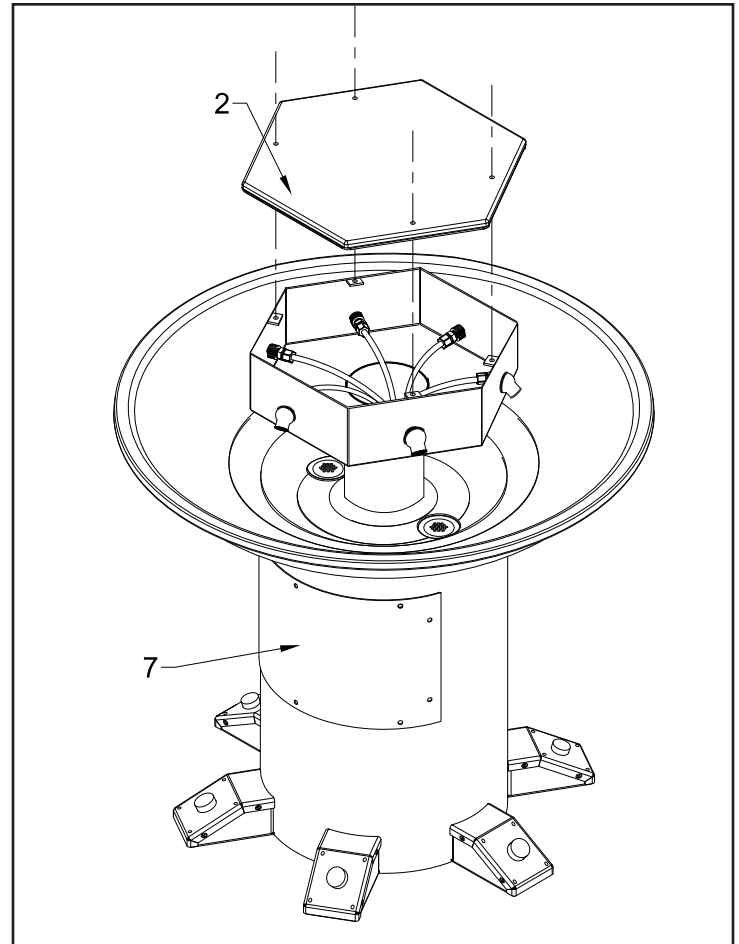

- 1.) Make all final plumbing connections to valve inlets using supplied flex hoses (flex hoses have shut-off valves attached that should be connected to the supply inlets).
- 2.) Once all of the connections in the actuator housings are complete, make final adjustments to valves and replace solid surface top cover and the two pedestal access covers with security screws.

JACO Fitting Instruction



Note: It is not necessary to disassemble this fitting for application. Merely insert tubing to stop and tighten seal.

1. Cut tubing end squarely and remove the internal burrs.
2. Insert the tubing through the back of the nut all the way through the nut assembly to the tube stop in the fitting body (see illustration). If the tubing does not enter the nut easily, loosen the nut one turn and reinsert the tubing all the way to the tube stop in the fitting body.
3. Turn the nut hand tight.
4. Wrench tighten the nut $1\frac{1}{2}$ - 2 turns.
5. All nuts must be retightened when the system reaches projected operating temperature.

Note: To ensure proper assembly, tubing MUST be fully inserted into the fitting body all the way to the tube stop.

Note: Squeaking sound when tightening nut is normal. For pipe threaded connections, Teflon tape must be used.

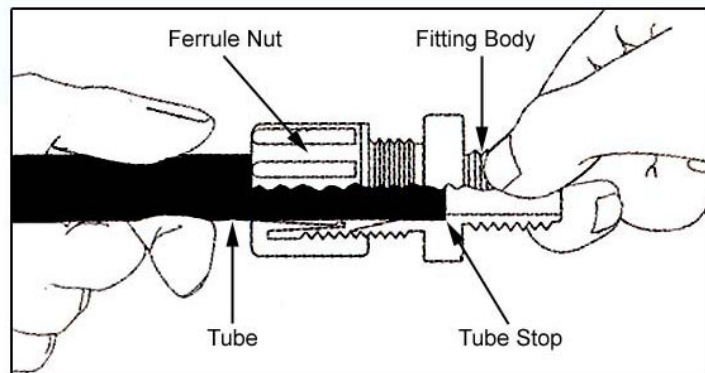
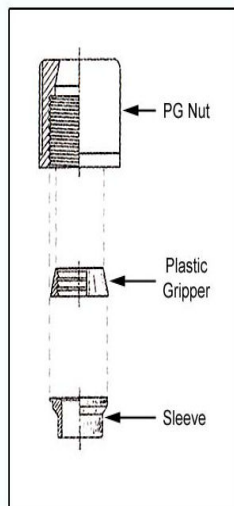

Adjustable Mixing Valve Installation

POWERS™

IS-P-e480

**HydroGuard® T/P Series e480
Lavatory Combination Valve**

Installation Instructions

To Install ■

NOTE: Installation should be in accordance with accepted plumbing practices. Flush all piping thoroughly before installation.

1. Locate a suitable place for the tempering valve. Valve should be accessible for service and adjustment and as close to the point-of-use as possible.
2. Connect hot and cold water to the supply valve using 1/2" NPT or 3/8" compression connections.
3. Connect outlet of tempering valve to fixture(s) using 1/2" NPT or 3/8" compression connections.
4. Turn on hot and cold water supplies. If any leaks are observed, tighten connections as necessary to stop leaks before proceeding.
5. Turn on fixture and allow water to flow for 2 minutes. Measure water temperature at outlet. If water is not at desired temperature, adjust as necessary.

Specifications ■

e480-001/2" NPT (Rough Bronze)
e480-011/2" NPT (Rough Chrome)
e480-103/8" Compression (Rough Bronze)
e480-113/8" Compression (Rough Chrome)
Capacity:4.0 gpm (15.0 l/m)
Approach Temperature:5°F (2.8°C) above set pt.
Max. Operating Pressure:125psi (862 kpa)
Max. Static Pressure:125psi (862 kpa)
Max. Hot Water Temperature:180°F (82°C)
Temp. Adjustment Range:	
.....	ASSE Type T/P: 95 – 110°F (43-48°C)
.....	ASSE Type T: 80 – 120°F (27-49°C)
Minimum Flow:0.5 gpm (2.2 l/m)
Checks:Integral
Construction:Cast Brass Body
Certified:CSA B125
ListingASSE 1016-1996 (Type T/P)
.....ASSE 1070

CALIFORNIA PROPOSITION 65 WARNING

WARNING: This product contains chemicals known to the State of California to cause cancer and birth defects or other reproductive harm. (California law requires this warning to be given to customers in the State of California.)
For more information: www.watts.com/prop65

Figure 1

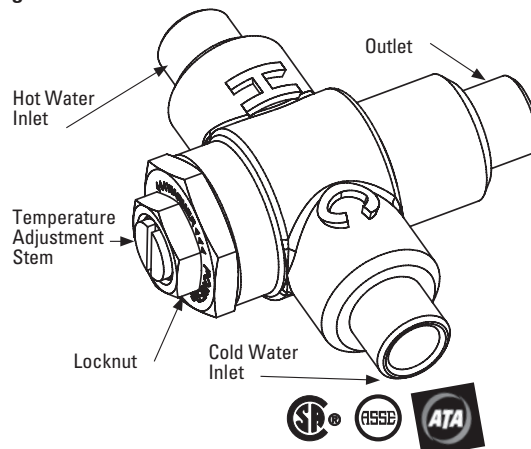
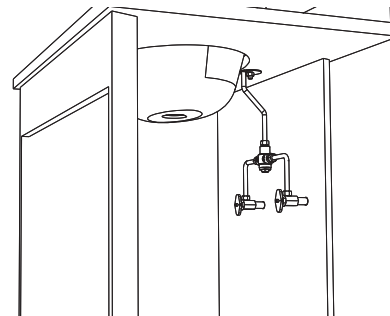

Figure 2: Typical Installation



To Adjust Temperature ■

1. Loosen locknut.
2. Turn on fixture and run water for at least two (2) minutes to allow supply temperature to stabilize.
3. Turn temperature stem counter-clockwise for hotter or clockwise for colder outlet temperature.
4. Tighten locknut to prevent accidental or unauthorized temperature adjustment.
5. Re-check outlet temperature.

Repair Kit ■

Motor Repair Kit.....480-270

Self-closing Pneumatic Valve- Operation Details

Three Major Components:

- (A) Remote pushbutton assembly
- (B) Pneumatic servomotor
- (C) Servomotor supply valve

Stainless steel separator cup (D)
divides the servomotor & supply valve.
The only interconnection is magnetic force

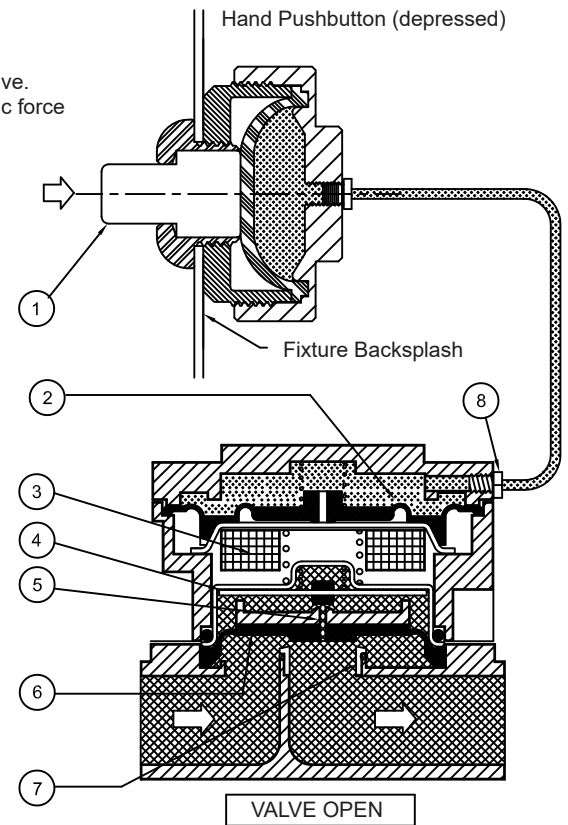
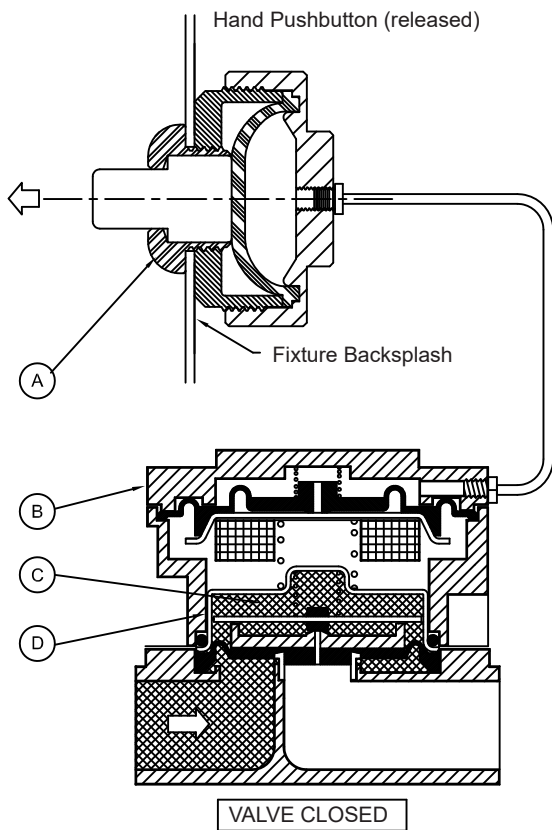

Valve Closes: releasing the pushbutton relieves pressure through the hose barb (8) into the chamber above the actuating diaphragm (2). The lack of air pressure in this chamber allows the diaphragm (2) and the magnet (3) to be forced up. The water side actuating disk (4) drops, covering the pilot orifice (5). Water pressure increases above the seat diaphragm (6), closing the diaphragm (6) against the seat (7).

Valve Opens: Depressing the button (1), forces air through the chamber above the actuating diaphragm. The air pressure on top of the actuating diaphragm (2) causes the diaphragm and magnet (3) to be forced down. The water side actuating disk (4) is pulled up by magnet (3) opening the pilot orifice (5), bleeding off line pressure from above the seat diaphragm (6). Water pressure then lifts the seat diaphragm (6) off the seat (7) and opens the valve.

Self-closing Pneumatic Valve- **Operation and Maintenance**

The Willoughby Pneumatic Valve Assembly is designed as a pressure operated, piloted orifice self-closing valve. This type of valve is used for lavatories as well as showers.

A strainer/checkstop is an integral part of the valve assembly and provides a means of shutting off the water if the valve needs servicing. A check valve in the checkstop eliminates backflow into the supply lines. Fine mesh stainless steel strainers keep normal line debris from interfering with the mechanical components of the valve.

By virtue of its design, a pneumatic self-closing valve is a normally closed valve. The valve will open when the hand or foot pushbutton is depressed. The valve will close when the hand or foot pushbutton is released. The operating sequence of the valve begins with pressing the pushbutton. Depressing the pushbutton forces air through the tubing into the air side top cover of the valve. The air pressure on top of the actuating diaphragm causes the diaphragm and magnet to be forced down. The magnetic force flowing through the barrier cup lifts the water side actuating disk. This allows the water pressure to lift the water side diaphragm off the valve seat and allow water to flow through the valve.

Releasing the pushbutton relieves pressure through the tubing which releases the pressure above the actuating diaphragm. The lack of air pressure on top of the actuating diaphragm allows the magnet spring to lift the magnet up and away from the water side actuating disk. The water side spring on top of the water side actuating disk then forces the disk downward. This seals the pilot hole in the seat diaphragm assembly. The water pressure then increases above the seat diaphragm which closes the diaphragm against the valve seat and shuts the water off.

A piloted orifice in the valve uses the water pressure in the line to assist in opening and closing the valve. The pilot orifice extends through the center of the 3-pronged insert holding the water-side diaphragm and is opened and closed by a rubber bumper molded onto a stainless steel disk. The bypass orifice is molded in the edge of the diaphragm (some diaphragms may have two of them). All orifices must be clear for the valve to function properly.

If a pneumatic valve drips after shutting off and the seat and diaphragm have smooth sealing surfaces, a PVK-2 diaphragm assembly kit should be installed.

If a pneumatic valve does not open and the problem is not in the pneumatic pump or tubing, a PVK-1 motor assembly kit should be installed.

Liquid Soap Specification and Maintenance

(For models with “LSD” option only)

Liquid soap viscosity is measured in “cps” (centipoise). The liquid soap chosen to be used with Willoughby’s Liquid Soap Dispenser should be between 100cp and 2500cp.

The viscosity of the soap should be thin and free flowing.

Some soap types are available in a concentrate and must be diluted with water.

The pH (acidity) level should be in the range of 6.5 to 8.5.

Soap which is too acidic (pH less than 6.5) can corrode stainless steel and degrade rubber, plastic, or chrome-plated materials.

Soap that is outside the range of 6.5 - 8.5 might be harsh on the hands or skin.

(Generally, any quality soap meeting the viscosity and pH guidelines should work well.)

Recommended Maintenance Schedule

To maintain proper function, Willoughby’s Liquid Soap Dispenser should be cleaned periodically to remove soap residue. The Liquid Soap Spout should be soaked in hot water for a period of 30 minutes when cleaning is being performed. The soap tray should also be cleaned with hot water.

Care and Maintenance

Solid Surface Care

Surfaces may be easily cleaned using conventional cleaning agents such as an ammonia based liquid cleaner, (glass cleaner).

Dry stains on a matte finish can be removed with a 3M Scotch-Brite gray scouring pad or a mild abrasive cleaner.

Burns or scorches can be removed by sanding with coarse grit sandpaper followed by finer grit (220) sandpaper. Follow sanding with a 3M Scotch-Brite gray pad (or equivalent) to match finish of sanding area to surrounding area. A final buffing may be required on polished surfaces. Accidental nicks or chips can be repaired with special patch kits available in all colors.

Avoid exposing surfaces to strong chemicals such as acetone's; paint removers and sulfuric acid or hydrochloric chemical cleaners. Exposure to strong chemicals may result in permanent damage to surfaces.

Stainless Steel Care

Stainless Steels are basically alloys of iron and chromium and are corrosion resistant. Stainless steel has a bright surface that is easy to clean and is free from oxides. Therefore, cleaning of stainless steel is relatively simple and easy if done on a regular basis.

Frequency of cleaning should depend on the rate at which the fixture becomes dirty. Remember that fresh (soft) deposits of all kinds are relatively easy to remove, while removing older (hard) deposits are much more difficult. Establish a cleaning SCHEDULE.

Routine cleaning should involve ordinary soap or detergent and water, applied with a sponge, brush or cloth. Baking soda, borax or any of several non-abrasive commercial cleansing agents can help hasten the cleaning action. after scrubbing, rinse THOROUGHLY and wipe dry.

DO NOT use common steel wool, scouring pads, scrapers, wire brushes, files or other steel tools to clean stainless steel. Such items will scratch the surface or leave small particles of iron imbedded in the surface, which will eventually rust and stain the surface - even appearing as if the stainless itself was rusting.

Certain chemical compounds, if used on stainless steel, can give the appearance of rust and if allowed to stand for long periods of time, can pit the surface of stainless steel. Products containing hydrochloric acid, muriatic acid or potassium hydrochloride can ruin the surface.

Troubleshooting - Self-closing Pneumatic Valves

VALVE WILL NOT OPEN OR DELIVER WATER:

- (1) Check the plastic tubing that runs from the push button actuator to the pneumatic valve for air leaks.
- (2) Make sure the checkstop on the supply to the valve is fully open. Do not partially close the checkstop for any reason as it is not a throttling valve. The checkstop should be fully open (normal operation) or fully closed (when servicing the valve).
- (3) Close checkstop and then inspect the strainer in the supply line (installed after the checkstop) to make sure the strainer is not blocked or partially blocked prohibiting water flow.
- (4) Separate valve motor from valve base by removing the (4) #8 screws. Remove the top cover from the motor. Check the actuator diaphragm for holes. **Do not lose the actuator spring.**

VALVE WILL NOT SHUT OFF:

- (1) Separate valve motor from valve base by removing the four (4) #8 screws.
- (2) Inspect the water diaphragm assembly to see if bypass hole in diaphragm is blocked. Remove any debris by blowing on diaphragm or using force of air. Do not use any tool (such as straight pin) to remove any debris. Enlarging the hole will shorten or make for erratic cycling.

VALVE CONTINUES TO TRICKLE OR PARTIALLY DELIVER WATER AFTER CYCLE IS OVER:

- (1) Inspect seating area on valve base to make sure no debris, pitting or scoring is present.
- (2) Clean seat or replace seat (if a brass base) as necessary.
- (3) Inspect seating area of diaphragm for debris, clean as necessary. If debris has caused permanent indentations in the rubber, it may have to be replaced.

**DRAWING: General Dimensions
 and Rough-in Detail**

 <p>WILLOUGHBY</p>	TITLE: 36" SOLID SURFACE WASHFOUNTAIN WAF-3606-FL-FO-GG 6 STATION			DRAWING #: A3606-0099
	DIMENSIONS ARE +/- 1/4" EXCEPT AS NOTED	MATERIAL: NOTED	DRAWN BY: MCL DATE: 1/23/15 SCALE: NOT TO SCALE	REV. #: B 6/26/15 STANDARD DWG.

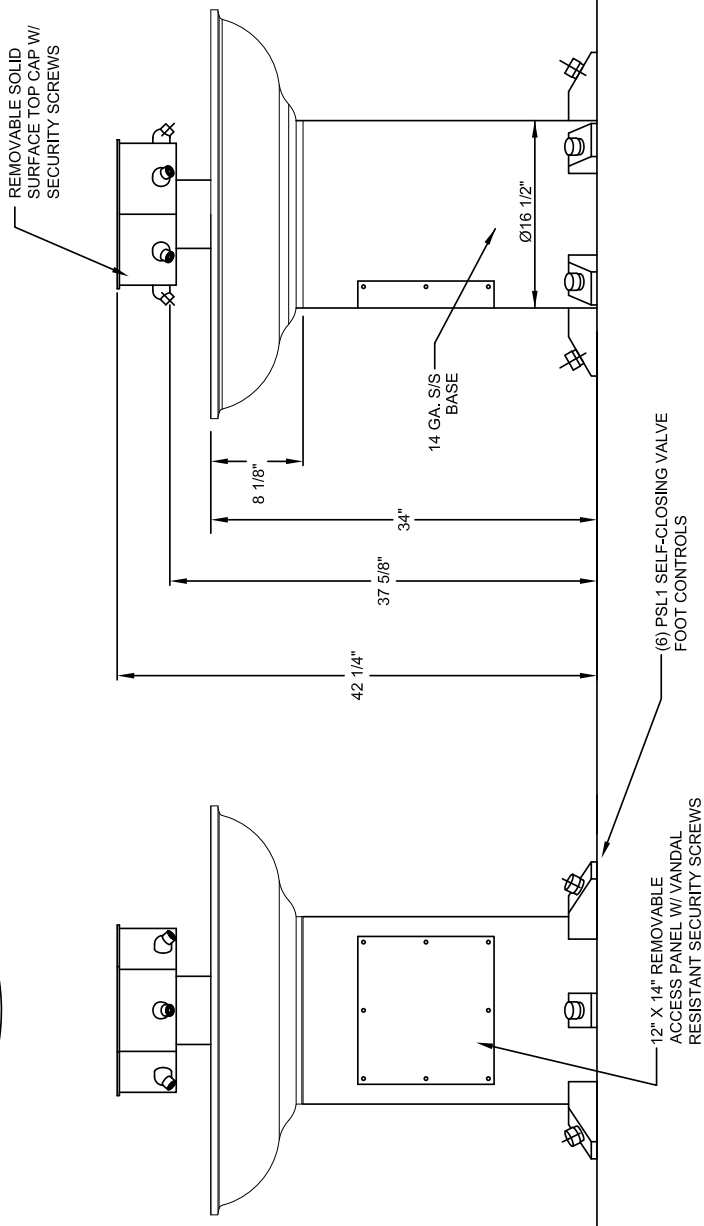
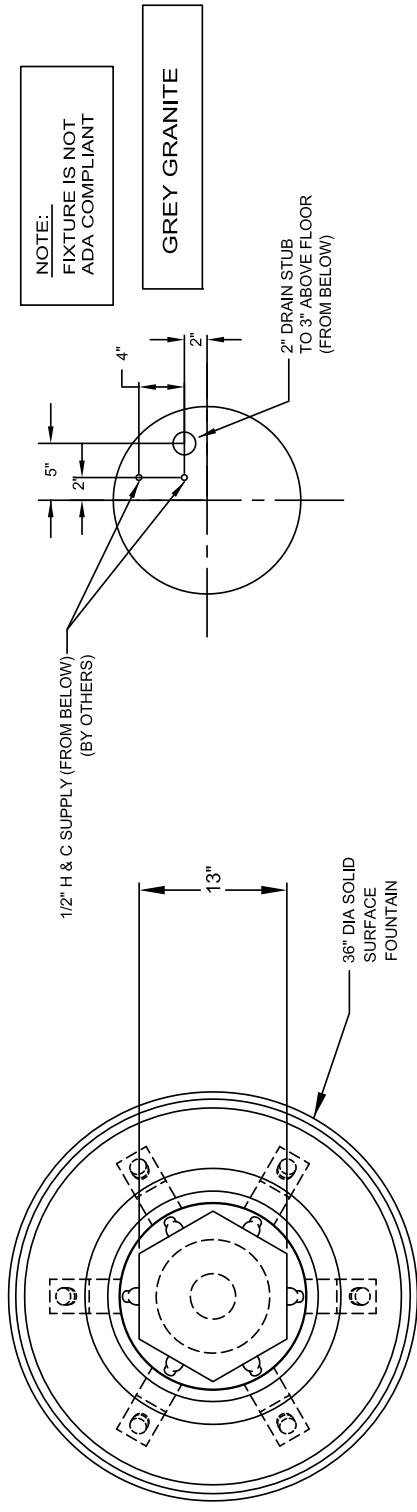

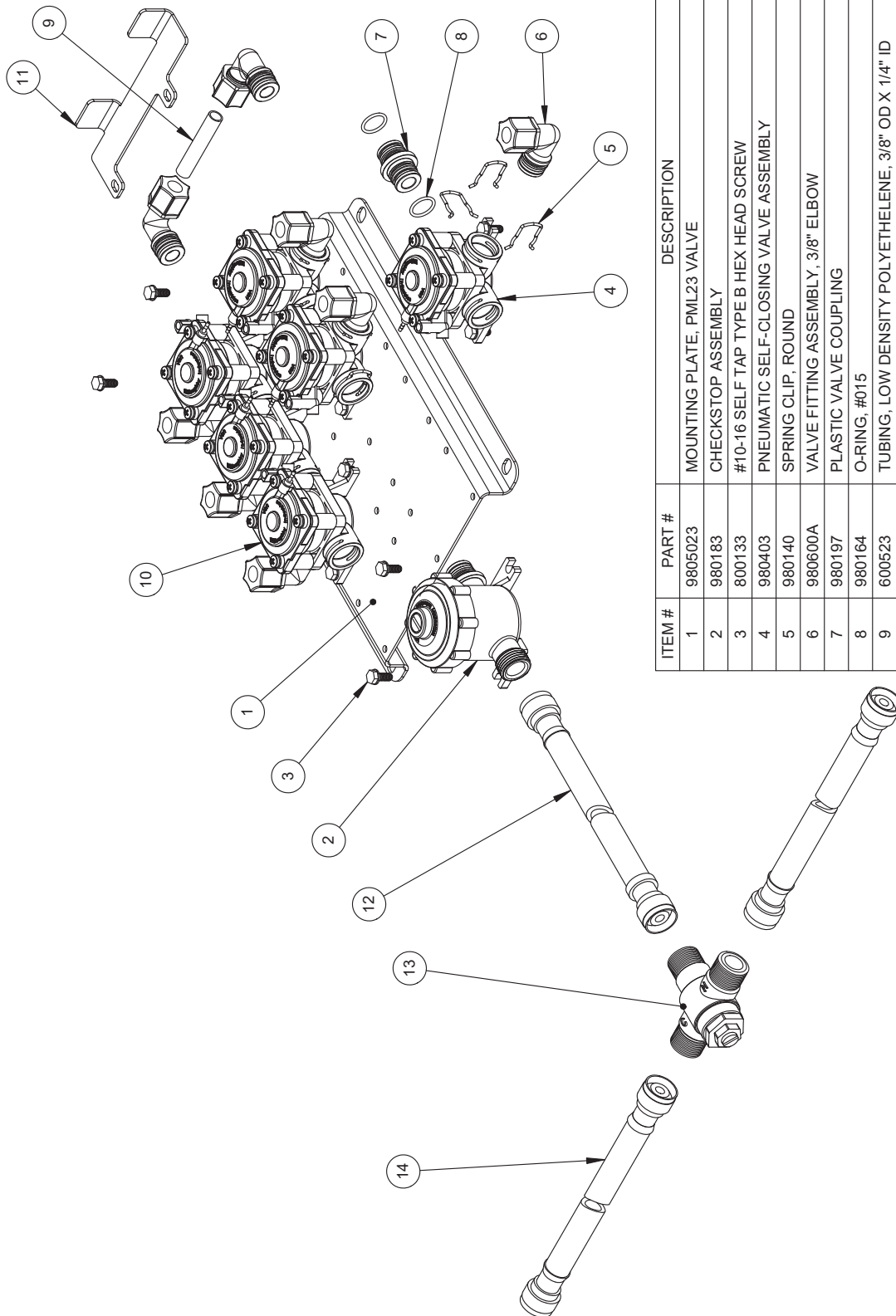

ITEM #	PART #	DESCRIPTION	QTY.
1	9805023	MOUNTING PLATE, PML23 VALVE	1
2	980183	CHECKSTOP ASSEMBLY	1
3	800133	#10-16 SELF TAP TYPE B HEX HEAD SCREW	16
4	980403	PNEUMATIC SELF-CLOSING VALVE ASSEMBLY	5
5	980140	SPRING CLIP, ROUND	17
6	980600A	VALVE FITTING ASSEMBLY, 3/8" ELBOW	8
7	980197	PLASTIC VALVE COUPLING	4
8	980164	O-RING, #015	8
9	600523	TUBING, LOW DENSITY POLYETHYLENE, 3/8" OD X 1/4" ID	1
10	980403PR	PNEUMATIC SELF-CLOSING VALVE ASSY - RIGHT PLUGGED PORT	1
11	S301406	BRACKET, ELBOW SUPPORT	1
12	980506	6" FLEX HOSE, 1/2 F.I.P CONNECTION	1
13	700480ELF	MIXING VALVE, TMV, LEAD FREE, LF-E480	1
14	980520	20" FLEX HOSE, 1/2 F.I.P CONNECTION	2

Willoughby Industries, Inc.
Indianapolis, Indiana

TOLERANCES EXCEPT AS NOTED

2 PLCS: #0.01
FRACTIONS: #1/32
ANGLE: #1°

SCALE: 1:3.5

SIZE: A

MATL: N/A

REV: C

ORIG: TRB

11/7/11

REV: EEF

12/12/17

STANDARD SHEET: 1 OF 2

TITLE / DESC: VALVE ASSY, WASHFOUNT 6-STATION (SELF CLOSING)

PART #: 803105-6SW

DRAWING: Self-closing Pneumatic Valve Detail

DRAWING: Self-closing Pneumatic Valve Detail

		Willoughby Industries Inc. Indianapolis, Indiana		Title or Part Description: SELF CLOSING PNEUMATIC VALVE ASSY, LEFT - PLUGGED PORT		Drawing #: 980403PL	
Tolerances Except as Noted		2 Places +/- .03 3 Places +/- .015 Angle +/- 1°		Material:		Revision #: A	
Job Name: N/A		Scale: 1:8		Date: 11/2/12		Approved By:	
PART #		DESCRIPTION		QTY.		Sheet: 1 Of 1	

ITEM NO.	SUB-ASSY #	PART #	DESCRIPTION	QTY.
1	N/A	980001	#8-32 x 1 1/4" SCREW	4
2	N/A	980002	SPLIT LOCK WASHER	4
3	N/A	380840	PUSH-IN HOSE BARB (BRASS)	1
4	N/A	380801M	AIR SIDE TOP COVER	1
5	N/A	980134	AIR SIDE SPRING	1
6	N/A	980130	AIR SIDE DIAPHRAGM	1
7	980405	980131	CUP, MAGNET	1
8	N/A	980132	MAGNET	1
9	N/A	980135	MAGNET SPRING	1
10	N/A	380802M	VALVE MOTOR BODY	1
11	N/A	980127	O-RING M1.5x32 BUNA-70	1
12	N/A	980126	BARRIER CUP	1
13	N/A	980136	WATER SIDE SPRING	1
14	980310	980161	RUBBER BUMPER	1
15	980305	980125	WATER SIDE ACTUATING DISK	1
16		980128	3 PRONGED INSERT	1
17		980129	WATER SIDE DIAPHRAGM	1
18	N/A	980420L	SINGLE TEMP BASE, LEFT - PLUGGED PORT W/INSERTS	1

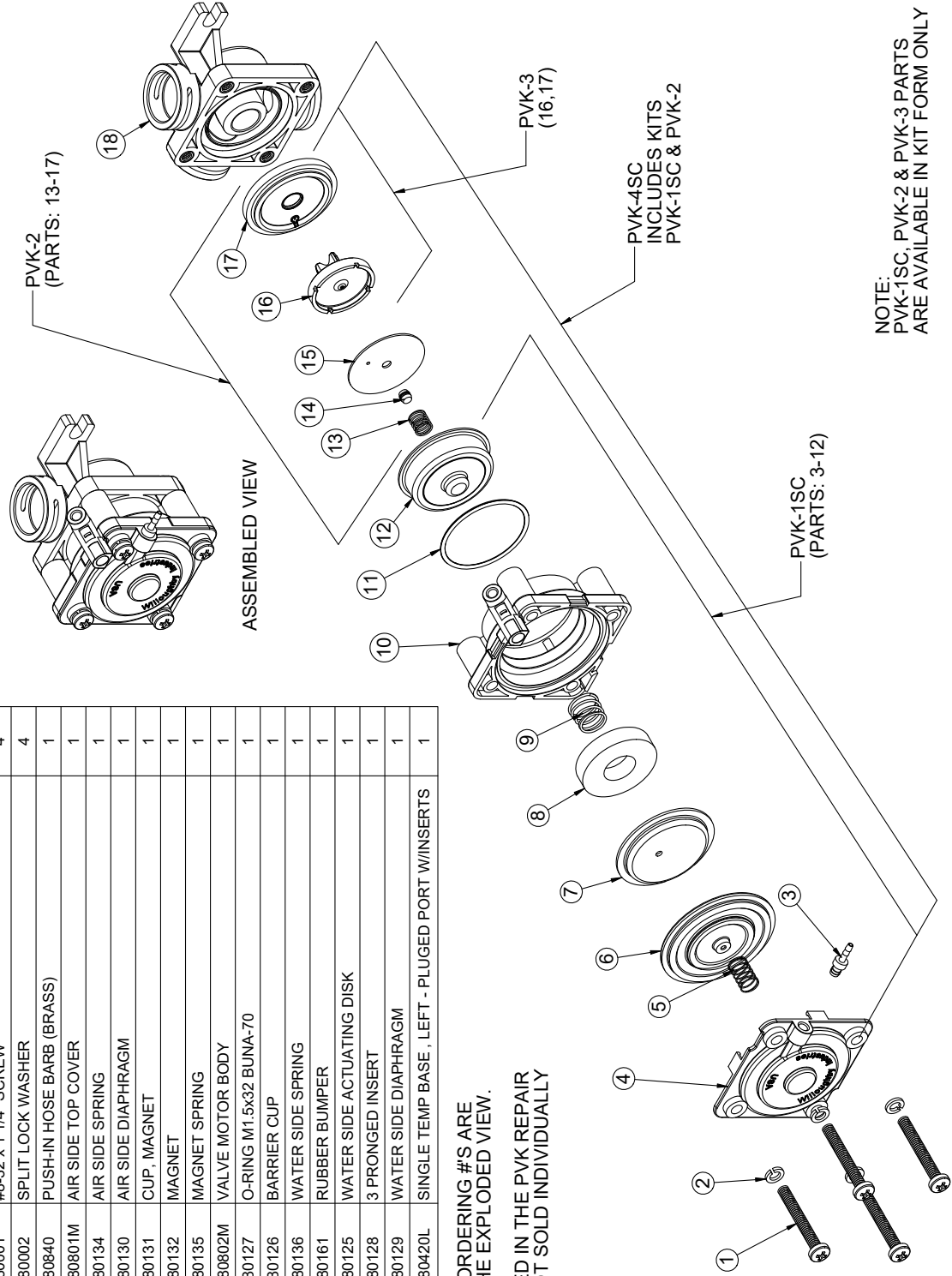

NOTE: REPAIR KIT ORDERING #'S ARE LISTED IN THE EXPLODED VIEW.
NOTE: PARTS LISTED IN THE PVK REPAIR KITS ARE NOT SOLD INDIVIDUALLY

NOTE: PVK-1SC, PVK-2 & PVK-3 PARTS ARE AVAILABLE IN KIT FORM ONLY

DRAWING: Push Button Detail

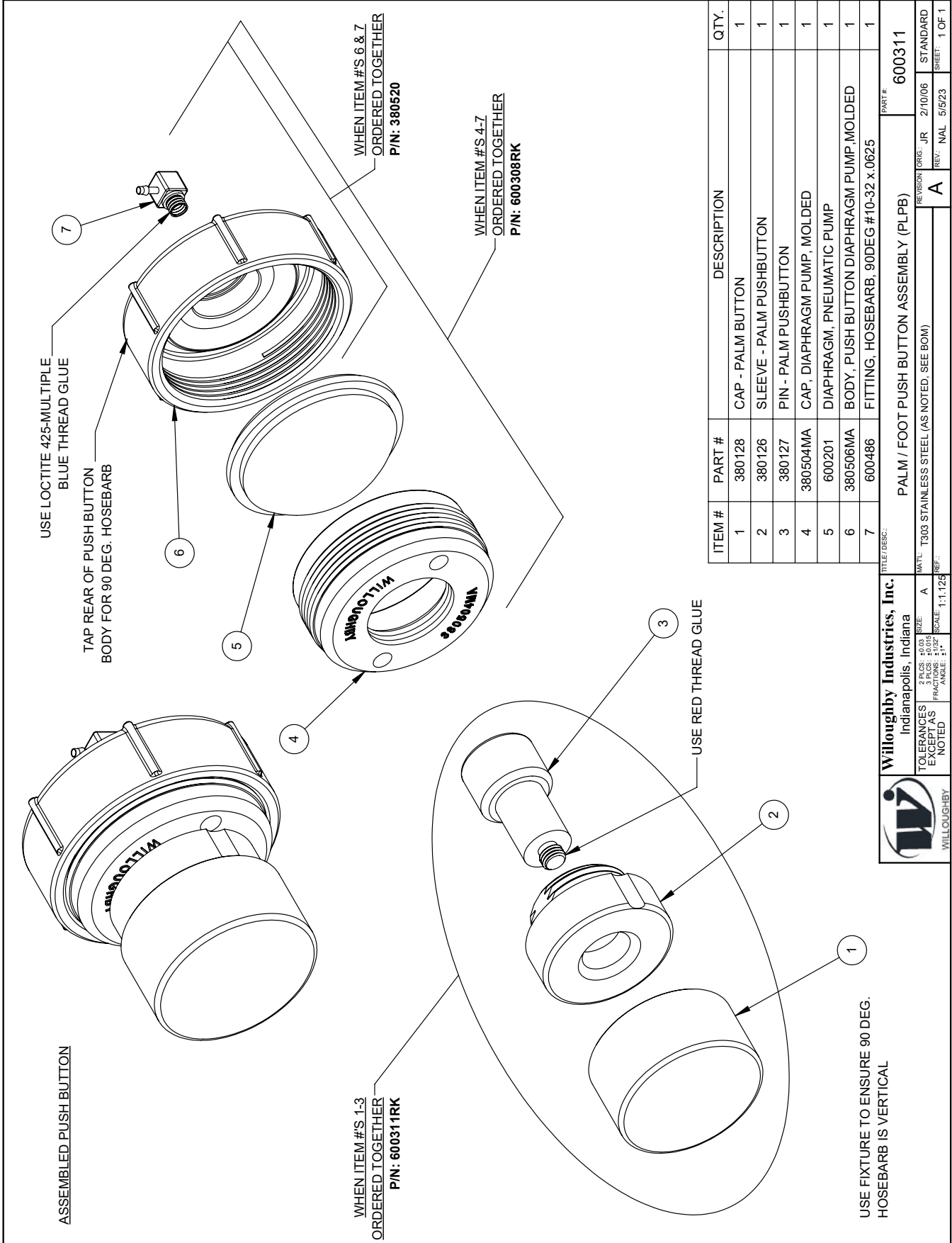

DRAWING: Spray Head Detail

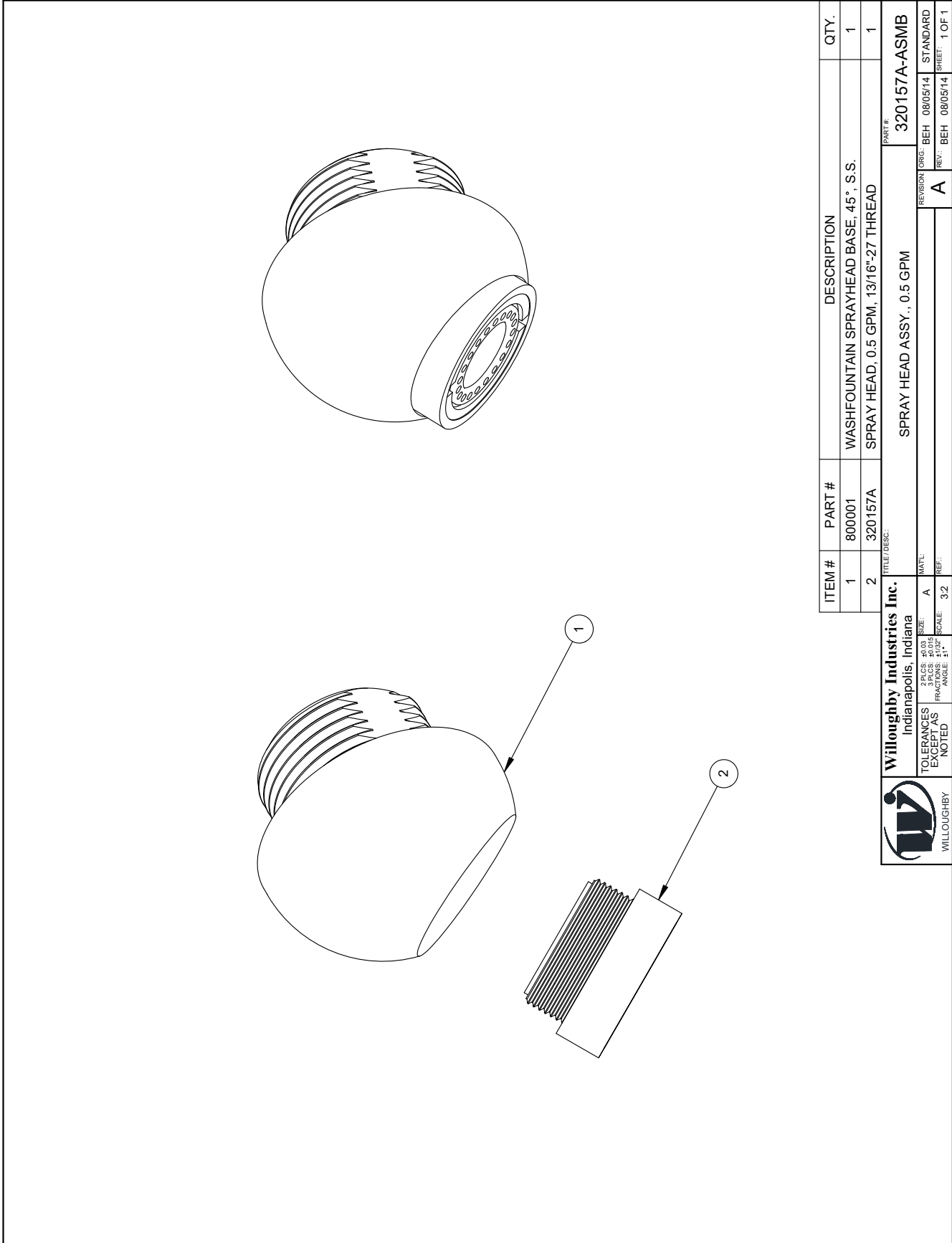

ITEM #	PART #	DESCRIPTION	QTY.
1	800001	WASHFOUNTAIN SPRAYHEAD BASE, 45°, S.S.	1
2	320157A	SPRAY HEAD, 0.5 GPM, 13/16"-27 THREAD	1

Willoughby Industries Inc.
Indianapolis, Indiana

2 PLS: ±0.03
3 PLS: ±0.015
EXCEPT AS NOTED

SCALE: 3/2" = 1"

MATL: A
REV: 08/05/14

REVISION DRES: A

TITLE/DESC: SPRAY HEAD ASSY., 0.5 GPM

PART #: 320157A-ASMIB

STANDARD: 1 OF 1

WILLOUGHBY

DRAWING: Liquid Soap Dispenser Detail

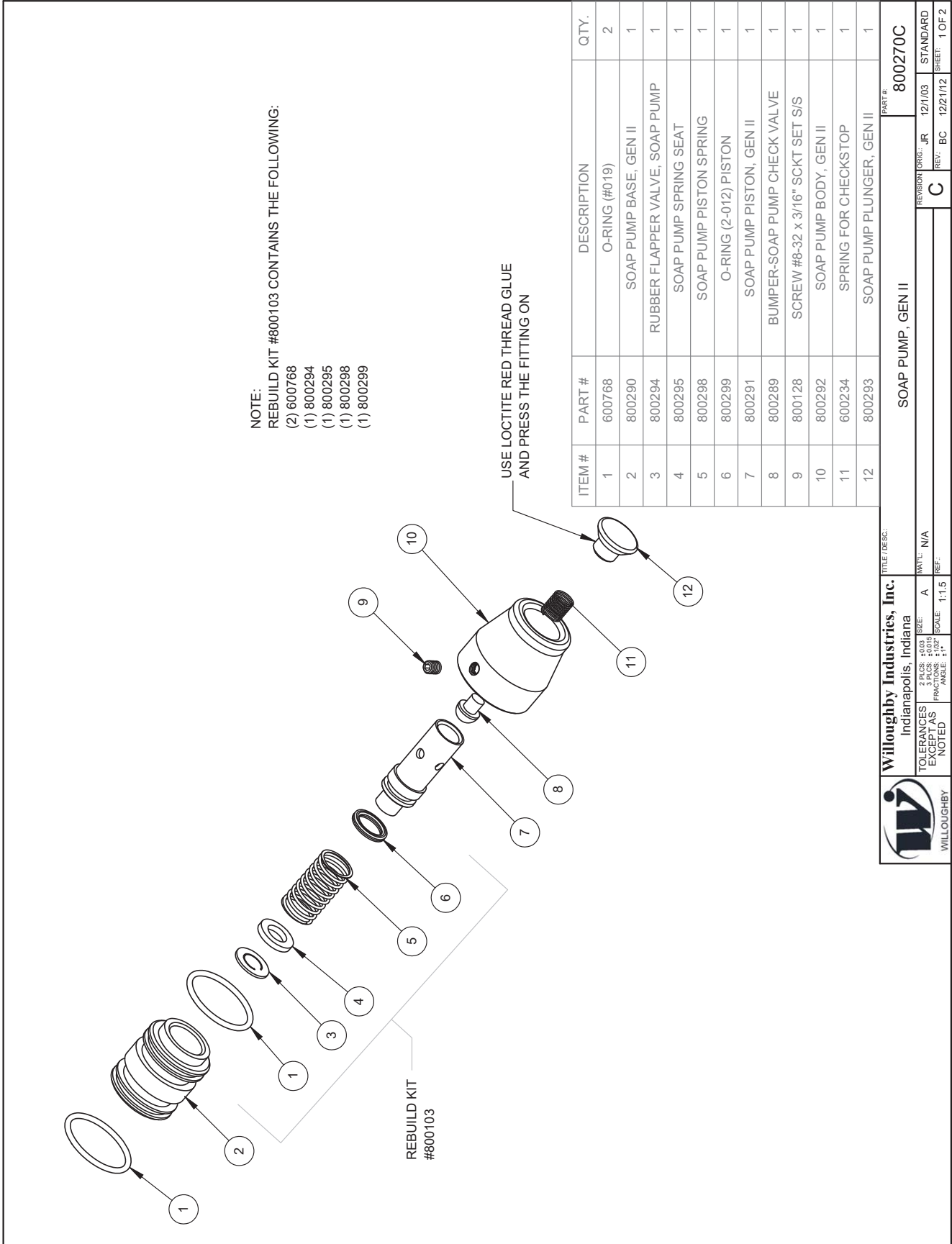

Warranty

Solid surface products are a homogenous blend of resins, mineral filler and colorant manufactured for panels, molded and/or shaped products and components. Solid surface products provide a luxurious appearance with the durability of stain proof, impact resistant, burn resistant material with the ease of maintenance and cleaning.

Willoughby Industries, Inc. warrants to commercial and institutional purchasers only that each unit will be free from defects in workmanship and materials under normal use and service upon the following terms and conditions. The period during which components are warranted is as follows:

1. Solid surface components are warranted for 2 years from date of shipment.
2. All other components warranted for 1 year from date of shipment.

This warranty does not cover installation or any other labor charges and does not apply to any components damaged by accident, abuse, improper installation or improper maintenance. This warranty does not cover any installation that did not comply with national, state and local building, plumbing or electrical codes. The warranty is limited to replacing or repairing at manufacturer's option, transportation charges prepaid by the purchaser, any component or part which upon our inspection shall be deemed as defective within the limitations of this warranty. The replacement or repair of defective units as stated in this warranty shall constitute the sole remedy of the purchaser and the sole liability of Willoughby Industries, Inc. Willoughby Industries, Inc. shall not otherwise be liable under any indirect damages caused by defects in the repair or replacement thereof.

This warranty only extends to commercial and industrial purchasers and does not extend to any others, including consumer customers of commercial institutional purchasers. This warranty is in lieu of all other warranties, expressed or implied, including implied warranty of merchantability or fitness for a particular purpose or otherwise.