

## DF-1812-FA Stainless Steel Small Profile Handicap-ADA Compliant Front Access Drinking Fountain

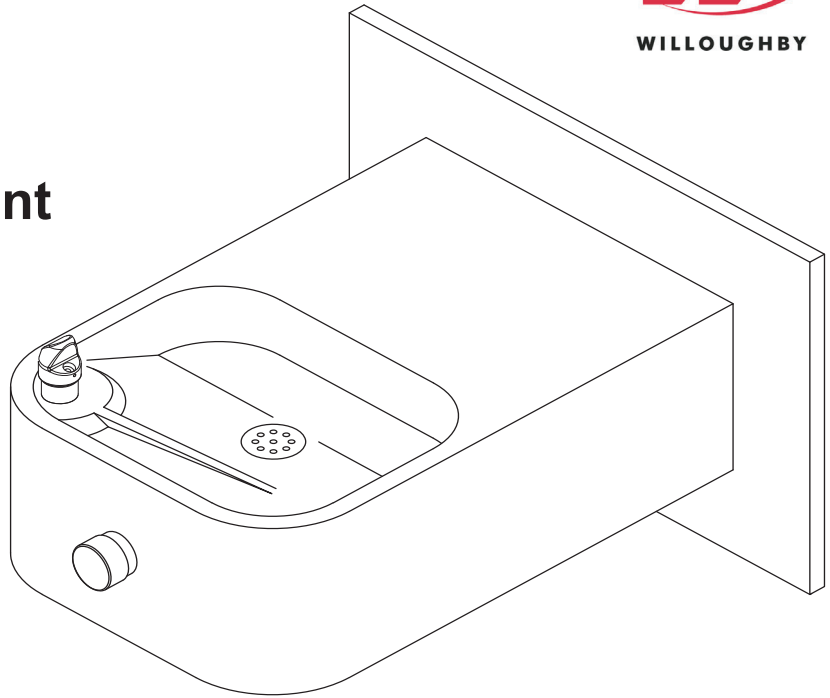

*(Unit may be shown with optional features)*



To specify fixture and accessories, use the Model Number and Options page.  
Example: To specify a Small Profile, Handicap-ADA Compliant, Front Access Drinking Fountain with standard drinking fountain bubbler, standard single temp. non-metering pneumatic valve and push button, standard removable 'p'-trap, and s/s wall back-panel  
Use the following Willoughby Model Number:  
**DF-1812-FA-CDB-PSL1-PLPB-RPT-WBP**

### Recommended Specifications

Stainless Steel, Small Profile, Handicap-ADA Compliant, Front Access Drinking Fountain shall be:  
Willoughby Model No. **DF-1812-FA**  
(select from model number and options list on next page)

Fixture shall be fabricated from 14 gauge, type 304 stainless steel. The construction shall be all-welded, with exposed stainless surfaces polished to a #4 satin finish.

Standard equipment shall include:

- Rectangular-shaped basin with rounded corners, 8-5/8" x 10-3/4" x 2" deep
- Removable stainless steel fast drain
- (CDB) stainless steel drinking fountain bubbler
- (PSL1) Single temperature, non-metering pneumatic valve w/ (PLPB) pneumatic palm push button
- (RPT) slip joint, cast brass union 'p'-trap (1-1/2")
- Removable bottom panel attached w/ vandal resistant screws

Cabinet interior shall be sound deadened with fire-resistant material.

#### Mounting:

Anchoring shall be from the front with mounting plate.  
Anchoring hardware by others.

Unit requires no chase area for installation and maintenance.

#### Vandal Resistance:

All push buttons and escutcheons are secured to the unit from within the fixture. Valves, water supplies and waste connections are concealed within. The bottom panel is removable and secured with vandal resistant security screws.

#### ADA and ANSI Compliant:

When the drinking fountain is mounted at standard 36" bubbler height, it is designed to comply with applicable ADA and ANSI Z124.3 and Z124.6 accessibility guidelines.

visit our website at [www.willoughby-ind.com](http://www.willoughby-ind.com)

5105 West 78th Street • Indianapolis, IN. 46268  
(317) 875-0830 • Fax: (317) 875-0837 • (800) 428-4065



MADE IN THE U.S.A.

# MODEL NUMBER AND OPTIONS:

## 1.) Drinking Fountain Model:

- DF-1812-FA      Stainless Steel, Small Profile, Handicap-ADA Compliant, Front Access Drinking Fountain

## 5.) Drinking Fountain Waste:

- RPT      Slip Joint, Cast Brass Union 'P'-trap (Removable, 1-1/2") (Standard)

## 2.) Bubbler Selection:

- CDB      Drinking Fountain Bubbler (Standard)

## 6.) Other Options:

- MT      Wall Template  
 WBP      Stainless Steel Wall Back-Panel  
 Other: \_\_\_\_\_  
 Other: \_\_\_\_\_

## 3.) Valve Selection:

- PSL1      Single Temp. Pneumatic Non-metering (Standard)

## 4.) Push Button Selection:

- PLPB      Pneumatic Palm Push Button (Standard)

Approved For Manufacturing By: \_\_\_\_\_ Date: \_\_\_\_\_ Company: \_\_\_\_\_  
 Wall Thickness: \_\_\_\_\_ Wall Type: \_\_\_\_\_

**VERIFY ALL DIMENSIONS WITH FACTORY PRIOR TO ROUGH-IN**  
 WILLOUGHBY RESERVES THE RIGHT TO MAKE CHANGES IN DESIGN AND DIMENSIONS WITHOUT FORMAL NOTICE AND WITHOUT INCURRING OBLIGATION.

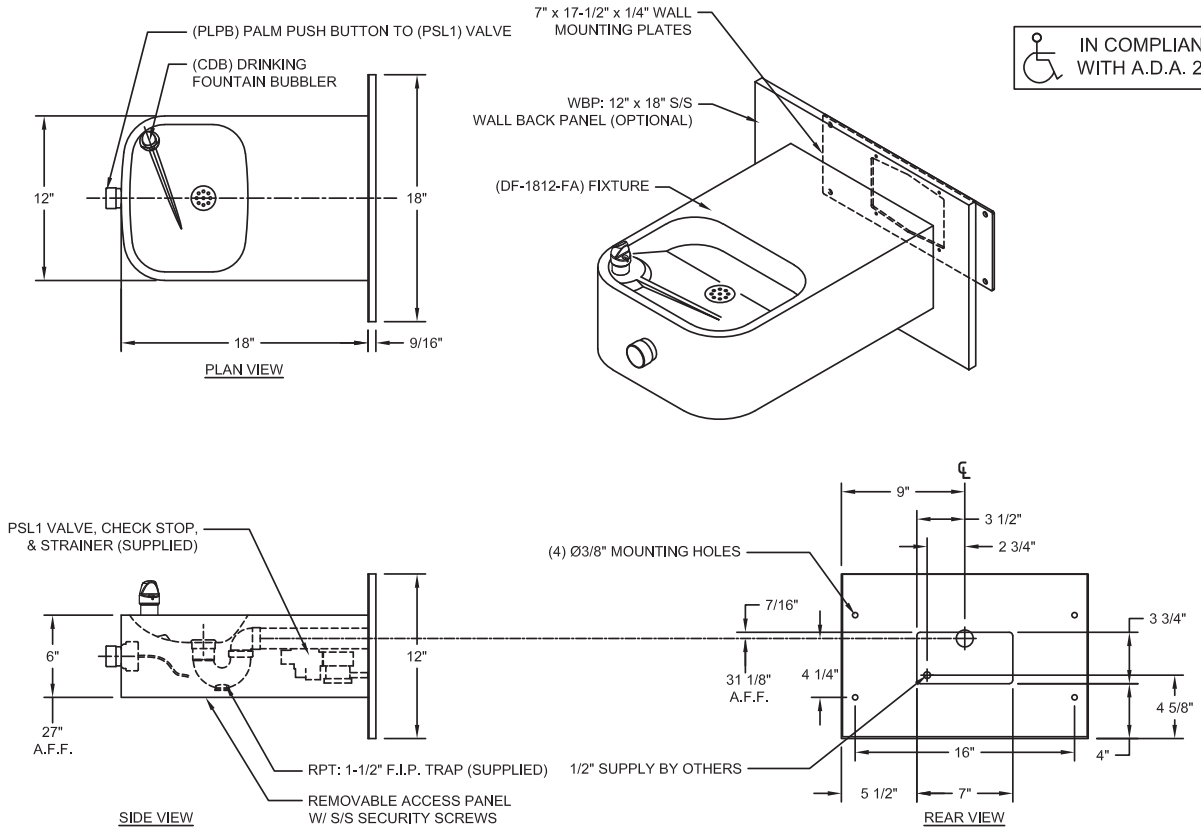

IN COMPLIANCE WITH A.D.A. 2010

visit our website at [www.willoughby-ind.com](http://www.willoughby-ind.com)  
 5105 West 78th Street • Indianapolis, IN. 46268  
 (317) 875-0830 • Fax: (317) 875-0837 • (800) 428-4065



MADE IN THE U.S.A.