

WILLOUGHBY INDUSTRIES, INC.

---

Water Management System II

# System Operator Manual

WATER MANAGEMENT SYSTEM II

# System Operator Manual

---

Revised 12/15/2020

© Willoughby Industries, Inc.

5105 W. 78th Street • Indianapolis, IN 46268

Phone 317-875-0830 • Fax 317-875-0837

# Table of Contents

<b>Table of Contents</b> .....	<b>i</b>
<b>Table of Figures</b> .....	<b>iii</b>
<b>Water Management System II</b> .....	<b>7</b>
<b>Understanding the WMS II Components</b> .....	<b>9</b>
<i>CVC/Plumbing Fixture Connections</i> .....	9
<i>Status Lights</i> .....	10
<i>Diagnostic Buttons</i> .....	10
<b>CELL VALVE CONTROLLER COMPONENTS</b> .....	<b>11</b>
<i>Power Light</i> .....	11
<i>Diagnostic Lights</i> .....	12
<i>Valve Output Lights</i> .....	12
<i>DIP Switches</i> .....	12
<i>Overflow Reset</i> .....	13
<i>CAN Bus Network Connections</i> .....	13
<b>STANDARD CVC CONFIGURATIONS</b> .....	<b>14</b>
<b>Stand-alone Mode of Operation</b> .....	<b>17</b>
<b>Networked Mode of Operation</b> .....	<b>19</b>
<b>FEATURES</b> .....	<b>19</b>
<b>STARTING THE OPERATOR STATION PROGRAM</b> .....	<b>20</b>
<b>SCREEN LAYOUT</b> .....	<b>21</b>
<i>Status Bar</i> .....	21
<i>Control Toolbar</i> .....	22
<i>Main Toolbar</i> .....	22
<i>Build Toolbar</i> .....	23
<i>Main Menu</i> .....	23
<i>Fixtures</i> .....	23
<i>Level 2 Layout</i> .....	23
<i>Level 1 Floor Plan</i> .....	24
<b>WMS II FIXTURES</b> .....	<b>25</b>
<i>Fixture Types</i> .....	25
<i>Fixture Status</i> .....	26
<i>Fixture Overuse</i> .....	27
<i>Selecting Fixtures</i> .....	28
<b>PROGRAM PREFERENCES</b> .....	<b>29</b>
<i>Toolbars</i> .....	30
<i>Sound</i> .....	33
<i>Alarms</i> .....	34
<i>FlushGuard</i> .....	35
<i>Logging</i> .....	37
<b>ALARMS</b> .....	<b>38</b>

TABLE OF CONTENTS

COMMAND REFERENCE .....	40
<i>File Menu</i> .....	40
<i>Edit Menu</i> .....	41
<i>Fixtures Menu</i> .....	43
<i>View Menu</i> .....	53
POP-UP MENUS .....	60
HOW DO I . . . .....	62
<i>Lock a fixture</i> .....	62
<i>Assign scheduled lockout times</i> .....	62
<i>Unlock a fixture</i> .....	63
<i>Flush a toilet remotely</i> .....	63
<i>Change the timing of a valve</i> .....	63
<i>View a Level 2 floor plan</i> .....	64
<i>Display the Level 1 overview</i> .....	64
<i>Select all fixtures on the floor plan</i> .....	64
<i>Reset a toilet overflow alarm</i> .....	65
<i>Reset a water overuse alarm</i> .....	65
<b>System Access</b> .....	<b>67</b>
<i>Security Levels</i> .....	67
<i>Security Preferences</i> .....	69
WMS CLIENTS OPTION (MULTIPLE WORK STATIONS) .....	70
<i>Client Access to the WMS II Server</i> .....	71
<i>Stopping Clients and the Server Remotely</i> .....	72
<i>Thinking Security</i> .....	73
1. Place the WMS II server in a secure location. ....	73
2. Use a WMS II client at the guard station. ....	73
3. Have a plan. ....	74
WMS API INTEGRATION CLIENTS OPTION (MULTIPLE WORK STATIONS).....	74
<b>Index</b> .....	<b>75</b>

# Table of Figures

FIGURE 1 - CELL VALVE CONTROLLER .....	11
FIGURE 2 - CVC CONNECTING TO TWO COMBINATION UNITS .....	14
FIGURE 3 - CVC CONNECTING TO 6 SHOWERS .....	15
FIGURE 4 - WMS II NETWORK MODE .....	16
FIGURE 5 - WMS II DESKTOP ICON .....	20
FIGURE 6 - WMS II SCREEN LAYOUT .....	21
FIGURE 7 - CONTROL TOOLBAR.....	22
FIGURE 8 - MAIN TOOLBAR .....	22
FIGURE 9 -BUILD TOOLBAR.....	23
FIGURE 10 - LEVEL 1 LAYOUT .....	24
FIGURE 11 - FIXTURE TYPES.....	25
FIGURE 12 - FIXTURE STATUS .....	26
FIGURE 13 - FIXTURE OVERUSE.....	27
FIGURE 14 - SELECTED FIXTURE .....	28
FIGURE 15 - TOOLBARS PREFERENCES .....	30
FIGURE 16 - SINGLE VERSUS SPLIT COMBINATION UNIT LOCK ICONS .....	31
FIGURE 17 - SPLIT COMBINATION LOCK POSSIBILITIES .....	32
FIGURE 18 - SOUND PREFERENCES .....	33
FIGURE 19 - ALARMS PREFERENCES.....	34
FIGURE 20 - FLUSHGUARD PREFERENCES .....	35
FIGURE 21 - LOGGING PREFERENCES.....	37
FIGURE 22 - POP-UP ALARM WINDOW .....	38
FIGURE 23 - FILE MENU .....	40
FIGURE 24 - EDIT MENU .....	41
FIGURE 25 - COMMUNICATION SETTINGS .....	41
FIGURE 26 - FIXTURES MENU .....	43
FIGURE 27 - VALVE TIMING .....	44
FIGURE 28 - TOILET OVERUSE DIALOG .....	45
FIGURE 29 - SHOWER OVERUSE DIALOG .....	46
FIGURE 30 - AUTO ACTUATION DIALOG FOR TOILET .....	46
FIGURE 31 - AUTO ACTUATION DIALOG FOR HANDICAPPED SHOWER .....	47
FIGURE 32 - SCHEDULED PERMIT .....	49
FIGURE 33 - EDIT SCHEDULE.....	50
FIGURE 34 - REMOTE VALVE ACTIVATION FOR COMBINATION UNIT LAV .....	52
FIGURE 35 - REMOTE VALVE ACTIVATION FOR DUAL-TEMP HANDICAPPED SHOWER .....	52
FIGURE 36 - VIEW MENU.....	53
FIGURE 37 - VIEW LOG FILE.....	54
FIGURE 38 - ABOUT WINDOW .....	58
FIGURE 39 - FIXTURE PROPERTIES.....	59
FIGURE 40 - CVC PROPERTIES .....	60
FIGURE 41 - POP-UP MENU FOR FIXTURES.....	61
FIGURE 42 - POP-UP MENU FOR FLOOR PLAN.....	61
FIGURE 43 - WMS II USER LEVELS .....	67
FIGURE 44 - USER MANAGEMENT WINDOW.....	68
FIGURE 45 - CREATING NEW USER ACCOUNT .....	68
FIGURE 46 - SECURITY LEVEL TIME OUTS .....	69

TABLE OF FIGURES

FIGURE 47 - NETWORK PREFERENCES – WMS CLIENTS.....	70
FIGURE 48 - SHORTCUT FOR CLIENT.....	71
FIGURE 49 - USER MANAGEMENT WINDOW WITH CLIENTS .....	72
FIGURE 50 - LOGGED ON USERS .....	72
FIGURE 51 - NETWORK PREFERENCES – API INTEGRATION CLIENTS .....	74





# Water Management System II

**T**he Willoughby Water Management System II (WMS II) is a combination of electronic controls and computer software intended to be run on a Operator Station PC. The system is used to monitor, control and manage the use of water in a penal correction facility.

When used in a networked mode, an Operator Station located at a central location, such as a guard station, can monitor and control the electronic controls of each fixture attached to the network. The use of the fixture is controlled by an electronic control called the **Cell Valve Controller (CVC)**. The Cell Valve Controller is responsible for allowing the flow of water when requested by the inmate. The Operator Station can also change the programmed settings of each CVC on the network.

When used in a stand-alone mode, the system is comprised of Cell Valve Controllers that control the water use of the plumbing fixtures. A portable computer may be connected to change the programmed settings of the Cell Valve Controllers. Also, the CVC can be preprogrammed at the factory if a local computer with WMS II software is not available.



## Understanding the WMS II Components

The WMS II CVC is an electronic control that is attached to the plumbing fixtures in order to control the water use of each fixture. A single CVC is capable of controlling up to 2 combination units, 6 showers or other mixes of fixtures. Additional configurations are possible with up to 6 valves per CVC – contact your Willoughby representative for assistance in using the CVC in other configurations.

The CVC receives a signal from the plumbing fixture switch when the inmate wishes to activate the water faucet or flush the toilet. Upon receiving the switch signal from the fixture, the CVC first verifies that water use is allowed. The CVC then opens the plumbing valve for the programmed amount of time allowing water to flow to the fixture. After the programmed valve activation time has elapsed, the CVC closes the plumbing valve turning off the water.

The CVC contains diagnostic lights and push buttons to aid in troubleshooting. The diagnostic lights and buttons are described in greater detail in later sections.

All Cell Valve Controllers contain two CAN bus terminal blocks which allow up to 127 Cell Valve Controllers to be networked to the Operator Station computer on a single network using twisted-pair cabling. The Operator Station is used to monitor, control and configure the networked Cell Valve Controllers. The network cabling is not necessary for a CVC to be used in a stand-alone mode.

### CVC/Plumbing Fixture Connections

Connection from the CVC to the plumbing fixture is implemented through two different connectors. The plumbing valves are connected to the CVC using a 2-conductor cable and female push-on connectors.

The push buttons on the plumbing fixture(s) are connected to the CVC using a 2-conductor cable and male push-on connectors.

## Status Lights

The Valve Status Lights on the CVC are used to indicate the current status of each valve output. There is a green output light and a red status light for each valve.

The green output light indicates the active state of the valve output and will be turned on when the valve is energized to open (allowing water flow.)

The red status light indicates the Normal or Disabled state of each valve. If the valve use has been disabled, the red status light will display one of four patterns:

1. **Steady On** – The valve is disabled (locked out). Attempts to activate the valve from the push button will be ignored. If all three disabled lights for a given combination unit are on, then the combination unit has been locked from the Operator Station, either by a direct lock of the fixture done at the PC or a scheduled lockout period (not in a “schedule permit” period). If the overuse response is set to lockout, the steady on will also show for the corresponding valve(s) at are in fixture overuse.
2. **Low-speed Flashing** – This light pattern indicates that the valve is temporarily disabled during a re-initiate or an initiate delay cycle period. After the flush valve has opened and closed within a preset number of times within a preset time period, a re-initiate period is entered (programmable time). During this re-initiate time, any presses of the flush push button will be ignored and the flush valve will not activate until the fixture is reset or the delay time specified passes. (Low-speed flashing cycle is a repeating cycle of LED on for 0.5 second and off for 0.5 second.)
3. **High-sSpeed Flashing** – This light pattern occurs on a flush valve when an overflow has been detected. During this time, any presses of the flush push button will be ignored and the flush valve will not activate until the fixture is reset. (High-speed flashing cycle is a repeating cycle of LED on for 0.125 second and off for 0.125 second.)
4. **Short Strobe** – This indicates the valve has been activated. The corresponding green output light should also be on.

## Diagnostic Buttons

The diagnostic buttons are intended to aid the technician in debugging problems with the control system. Each button is connected in parallel with the fixture push buttons allowing the input to be triggered directly from the CVC. This feature allows the technician to test the CVC connections without leaving the vicinity of the CVC. To activate a water cycle, a diagnostic button may be pressed to simulate a push button input. There are also push buttons to simulate an overflow.

## Cell Valve Controller Components

The Cell Valve Controller is an electronic device that is used to monitor the input signals from plumbing fixtures and activate the corresponding plumbing valves. Many controllers can be networked to an Operator Station located at a guard station in order to monitor and control the networked controllers. The Cell Valve Controller also has the capability to store and monitor scheduled lockout times for each plumbing fixture preventing use of the fixture during scheduled times.

The major components of the Cell Valve Controller are used primarily for diagnostic purposes. The CVC does not have controls to adjust settings; instead the stand-alone portable computer or the Operator Station is used to configure the CVC or can also be pre-set at the factory. The primary components of the CVC are shown in *Figure 1*.

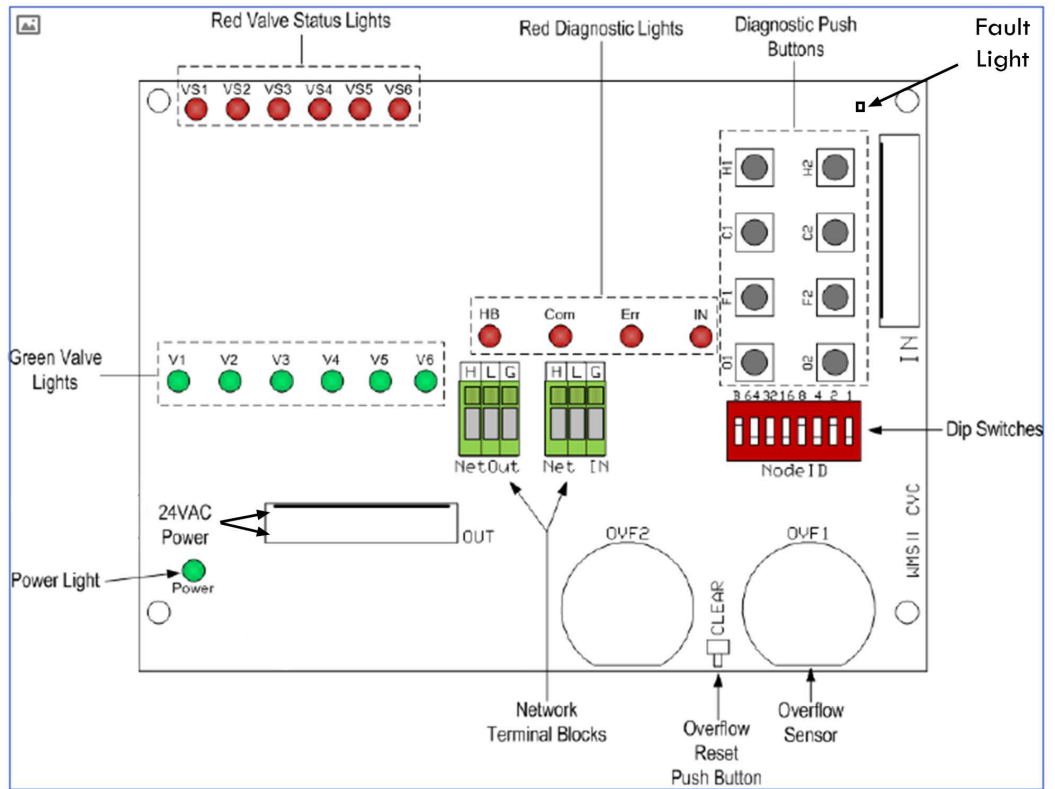

Figure 1 - Cell Valve Controller

### Power Light

The power light is a green light that is lit whenever 24 VAC power is supplied to the Cell Valve Controller. The power cable is connected to the electronics board at the factory.

## UNDERSTANDING THE WMS II COMPONENTS

### Diagnostic Lights

There are four red diagnostic lights that are used to indicate the activity and status of the Cell Valve Controller's software program.

**HB (Heart Beat):** The HB light should blink steadily on/off approximately every 1 second. When the light is blinking, the software program is running and the CVC is ready for use. If the HB light is not blinking, refer to the *System Troubleshooting Guide*.

**Com (Communication):** The Com light is used to indicate activity on the CAN bus network. The light will change status whenever a new packet of data has been received by the Cell Valve Controller. This light should blink only when the CVC is being programmed in stand-alone mode or when the CVC is connected on the CAN bus network to the Operator Station.

**Err (Error):** The Err light is used to indicate network communication errors. When information is received and not understood the light will flash intermittently. During normal operation of a networked system, this light will *NOT* be lit.

**IN (Input):** The IN light will flash anytime the CVC receives an input from a fixture push button, overflow sensor, reset switch, or diagnostic push button.

**Fault (Fault):** In the event of a reversed connection or improperly attached cable, the fault light will illuminate to notify the installer of a connection error.

### Valve Output Lights

The valve output lights indicate when the CVC sending power to the valve causing the valve to open and allowing water flow.

There are six green output lights (one for each output). The output light will be on whenever the corresponding plumbing valve is activated allowing water flow. The valve will remain on as long as the light is on. When the light turns off so does the valve and water flow.

### DIP Switches

The DIP switches are only used in network mode. The settings of the DIP switches adjust the communications speed and identify the CVC on the CAN bus network using a unique ID number.

The DIP switches are preset at the factory and will seldom need to be changed. The DIP switches should only be changed by qualified persons who understand the purpose of the DIP switches and have been trained in their use.

The seven DIP switches labeled 1, 2, 4, 8, 16, 32, and 64 on the circuit board are used to set the binary-weighted node address of each CVC. The one DIP switch labeled “B” is used to select the communication speed. With no jumper installed in the A2 position to the side of the DIP switch, 20Kbps is the selected communication speed with the switch off (down) and 50 Kbps with the switch on (up) position. (The speed choices selectable with the “B” switch may be increased from 20K/50K to 100K/125K by inserting a jumper in the A2 position on the circuit board, but this should not be done without consulting the factory.)

#### Overflow Reset

The Overflow Reset button is intended to reset a flush valve overflow alarm condition directly at the CVC. This is especially important when the CVC is being used in a stand-alone mode and an overflow condition has disabled the flush valve. An overflow condition is reported by the diagnostic lights of the CVC. When the flush valve disabled light is activated, the overflow condition must be reset before the flush valve can be used. To reset the overflow condition, press and hold the reset overflow switch for 1 second. After 1 second, the flush valve disabled light should turn off indicating that the flush valve is ready for use.

#### CAN Bus Network Connections

There are 2 terminal blocks used for connecting the Cell Valve Controller to the CAN bus network. The CAN bus network is wired from the Operator Station to the first CVC on the network. The network cable may be connected into the NET IN terminal block on the CVC. The network is continued from the remaining NET OUT terminal block to the next CVC and continues in this fashion until all controllers have been connected to the network.

## Standard CVC Configurations

The following figures illustrate some common configurations for connecting the Cell Valve Controllers to the plumbing fixtures, and the Operator Station.

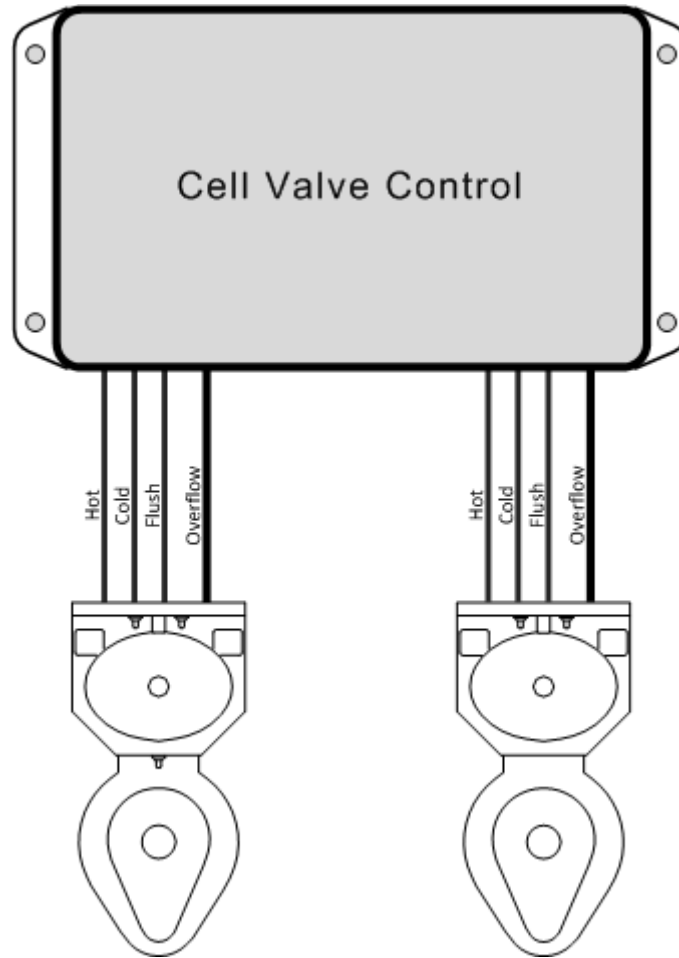

Figure 2 - CVC Connecting to Two Combination Units

*Figure 2* illustrates a Cell Valve Controller connected to two combination units. There are 3 push buttons, 1 overflow sensor (optional) and 3 valves for each combination unit connection to a CVC. This configuration may be used in either networked or stand-alone mode.

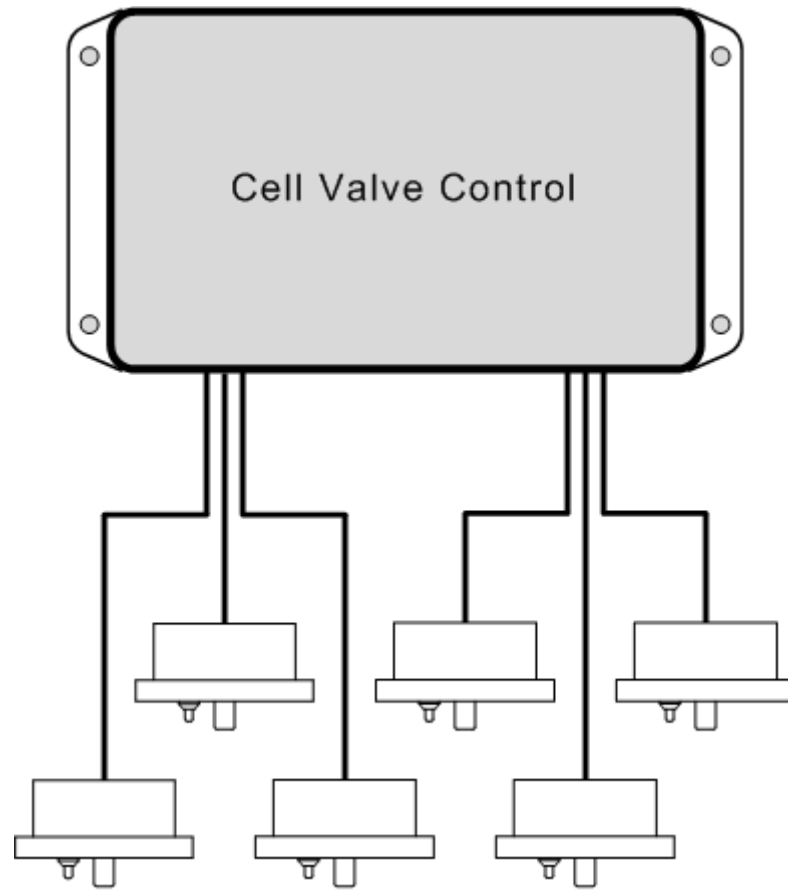

Figure 3 - CVC Connecting to 6 Showers

*Figure 3* illustrates a Cell Valve Controller connected to 6 single-temperature showers. Each shower has 1 push button and 1 plumbing valve. This configuration may be used in either networked or stand-alone mode.

The above two configurations are only a few examples of the many different configurations available. The WMS II system is flexible enough to handle a wide array of different configurations. Contact Willoughby for assistance in determining your WMS II configuration needs.

UNDERSTANDING THE  
WMS II COMPONENTS

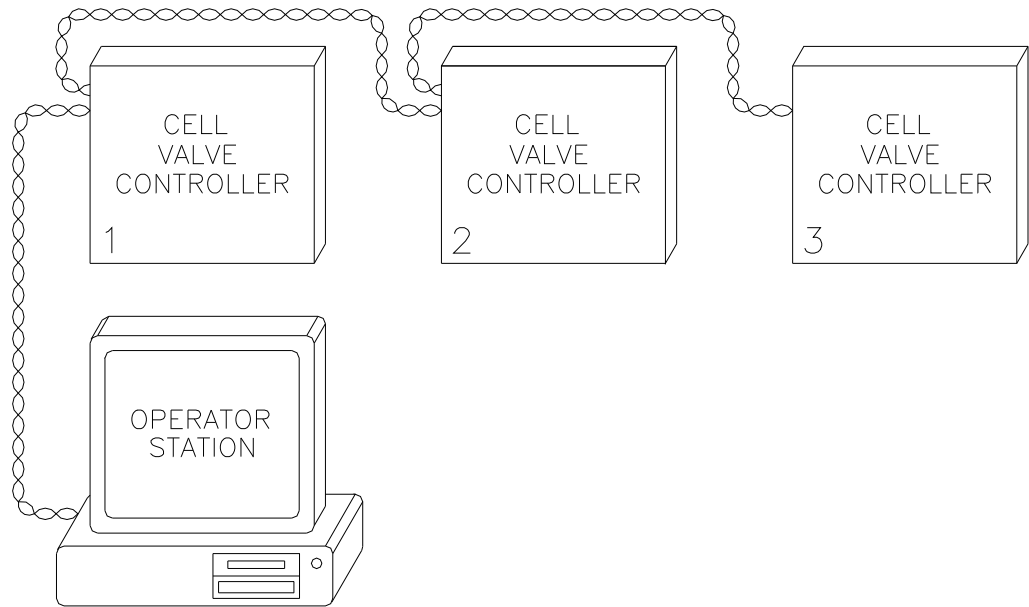

Figure 4 - WMS II Network Mode

*Figure 4* illustrates several Cell Valve Controllers in network mode. Twisted pair cabling is used to connect the Cell Valve Controllers to the Operator Station. The Operator Station is used to configure and monitor the Cell Valve Controllers connected to it using the CAN bus twisted pair network. Each Cell Valve Controller connected to the Operator Station must be assigned a unique ID number using the DIP switches on the Cell Valve Controller board (See *Cell Valve Controller Components* earlier). The configuration of each CVC is determined by the plumbing fixtures connected to it and is identical in either networked or stand-alone mode.

## Stand-alone Mode of Operation

The Cell Valve Controllers are pre-configured at the factory; however, it may be desirable to change the configured settings on one or more of the Cell Valve Controllers. When a Cell Valve Controller is installed in stand-alone mode, there is no Operator Station connected to a network that can be used to program the settings of the CVC.

A laptop can be used to connect to each CVC and use the WMS II software to change its settings, or the CVC could be returned to the Willoughby factory to have the settings changed as needed.

Most of the water management functions will work in stand-alone mode. The following are functions that will only work with a networked system:

1. Manual Lockout
2. Scheduled Permit
3. FlushGuard

**Note:** In stand-alone mode, there is no central Operator Station, so interface with the control system is done at the CVC usually located near the fixtures it controls. Inhibits of fixture functions can be determined by reading the status lights on the CVC, and alarms can be cleared by using the reset pushbutton on the CVC.

STAND-ALONE MODE OF OPERATION

## Networked Mode of Operation

In networked mode, the Cell Valve Controllers are connected using a CAN bus network to a computer located in a central location, such as a guard station. From the Operator Station, the Cell Valve Controllers can be monitored, modified and controlled. The Operator Station runs a special program that displays a map of the facility with the location and status of the networked fixtures shown on the map. The program communicates to the connected CVCs in order to display the current status of each fixture & valve connected to every CVC at all times. This chapter will document the features and operation of the Operator Station program.

### Features

Listed below are several of the features available on the Operator Station when connected to Cell Valve Controllers in networked mode:

- Intuitive interface that resembles the facility floor plan or a logical layout of the system.
- Easy selection of a single or multiple fixtures on a map.
- Logging of fixture/valve activity.
- Ability to modify fixture valve timing.
- Ability to lockout fixtures from the Operator Station.
- Ability to assign Scheduled Lockout times from the Operator Station.
- Remotely flush toilets from the Operator Station.

- Alarm indication for flush overflow and water overuse.
- Ability to prevent simultaneous toilet flushing.

## Starting the Operator Station Program

The Operator Station is configured at the factory so the WMS II software program is ready to launch from the desktop when the computer is turned on. The software will normally be left running at all times so that it is constantly monitoring and controlling the connected fixtures.

If for some reason, the software is not running and the computer is turned on, then the software can be started as described below.



Figure 5 - WMS II Desktop Icon

The above icon should be displayed on the desktop of the computer. Double-click on the icon to start the software. The software should open immediately and begin communicating with the connected fixtures.

## Screen Layout

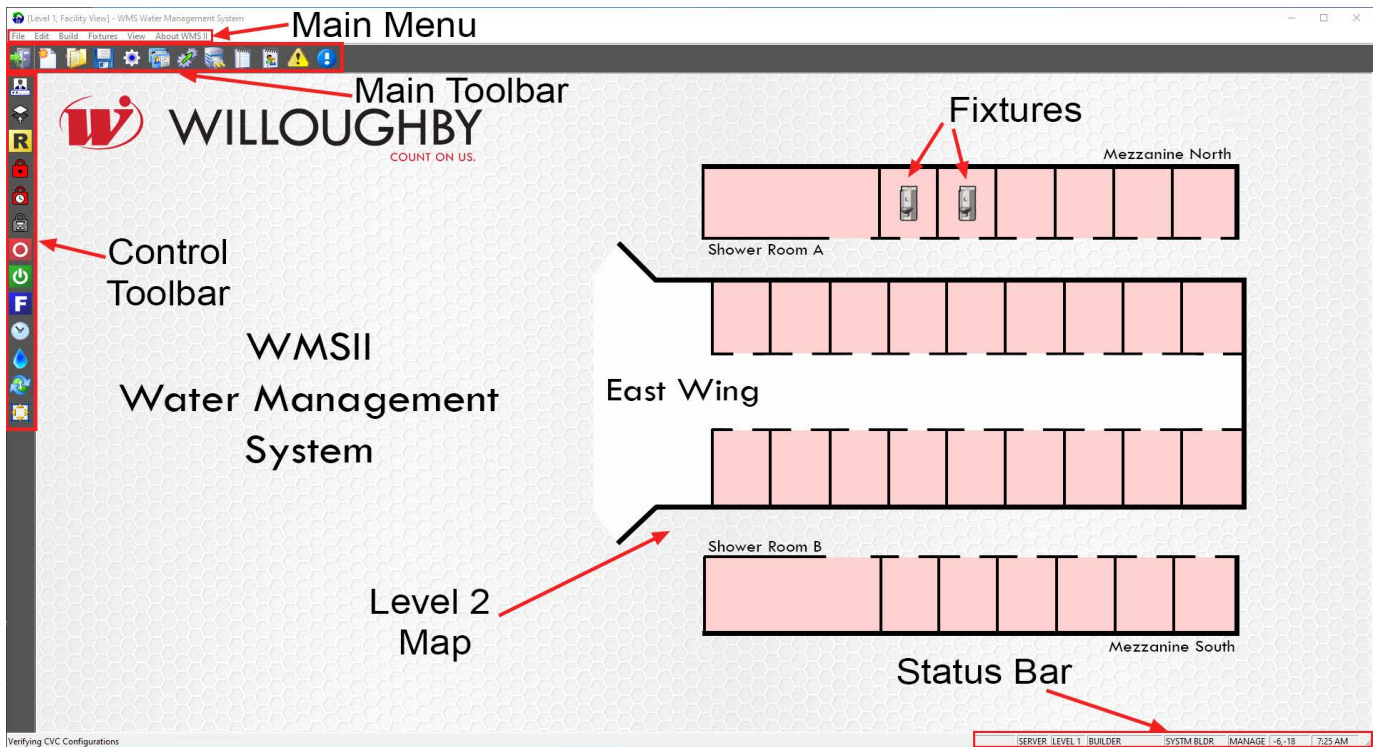

Figure 6 - WMS II Screen Layout

Figure 6 illustrates a sample screen layout with the major components marked. A description of the screen components are described below.

### Status Bar

The Status Bar is displayed along the bottom of the screen. The status bar is divided into sections of data referred to as panes. Each pane on the status bar contains a piece of information relating to the status of the program. A description of each pane follows below:

- Information Pane – the first pane occupies the left portion of the status bar. This pane will display any important information relating to the operation being performed.
- Modified Pane – the second pane is the first pane displayed with an outline. It displays the modified status of the program. If an operation occurs which modifies the program and requires the file to be saved, then this pane will display the word, *Modified*. If the Auto-Save options is turned on, then this

pane will never display the modified status as all changes are automatically saved as they occur.

- Level Pane – the next pane displays the floor plan level being displayed. The program is capable of showing two levels of detail for the facility floor plan. Level 1 typically displays an overview of the facility with no fixtures, while Level 2 floor plans show details of a particular area linked to an area of level 1 with fixtures being displayed. There can be several Level 2 floor plans displayed from a Level 1 floor plan. The status bar pane will display either *Level 1* or *Level 2*.
- Permissions Pane – the next pane will display *View*, *Operator*, *Supervisor*, *System Admin*, or *System Bldr* depending on the password used. Passwords can be preset at the factory.
- Manage Pane – the next pane should always display the word, *Manage*, for typical use.
- Coordinate Pane – the next pane displays the current coordinates of the cursor controlled by the mouse. Again, this is normally used only in *Build* mode by Willoughby Industries.
- Clock Pane – the last pane on the status bar displays the current time. If the time is incorrect, refer to your computer reference to determine the procedure for setting the correct time on the computer.

Control Toolbar



Figure 7 - Control Toolbar

The Control Toolbar can be displayed on the right or left hand side of the screen to accommodate left or right handed users. The Toolbar contains buttons for the most common tasks used in the WMS II program. Explanations of each button and the task that it performs appear later in this chapter.

Main Toolbar



Figure 8 - Main Toolbar

If the option to display the Main Toolbar is turned on, it will appear along the top edge of the screen. The Main Toolbar contains buttons for commands that are rarely used. Explanations of some of the buttons on the Main Toolbar appear later in this chapter.

#### Build Toolbar



Figure 9 -Build Toolbar

The Build Toolbar is also not normally displayed. The commands contained on the Build Toolbar are for the use of Willoughby Industries or a Willoughby representative in configuring the WMS II program for your use. A further explanation of the commands on the Build Toolbar is beyond the scope of this manual.

#### Main Menu

The Main Menu is displayed along the top edge of the screen. The menu contains all of the commands available in the program. Commands found on the Control Toolbar can also be found on one of the menu selections. The menu can also be used for less used commands which do not appear on the Control Toolbar. When a menu item is selected, a drop-down menu is displayed with a list of available commands. A further explanation of the menu commands appears later in this chapter.

#### Fixtures

The Level 2 layout displayed in *Figure 6* shows 2 combination units connected to the Operator Station. The WMS II program will be pre-configured at the factory to contain a separate fixture icon for each physical fixture attached to the WMS II network. The fixture icons are used to display the current status of the plumbing fixture. The fixture icon is also used to select fixtures to which control commands will be sent. See the next section, *WMS II Fixtures*, for an explanation of each fixture and its use.

#### Level 2 Layout

Displayed in *Figure 6* is a Level 2 layout with fixtures. If a two level layout is used for your configuration, the fixtures will be displayed on Level 2. On some configurations, a one level layout may be used. A one layout plan will contain the fixtures on Level 1 with no links to Level 2 layout. Level 2 layout are selectable from Level 1 and used to display the plumbing fixtures and their locations for a detailed area.

Level 1 Floor Plan

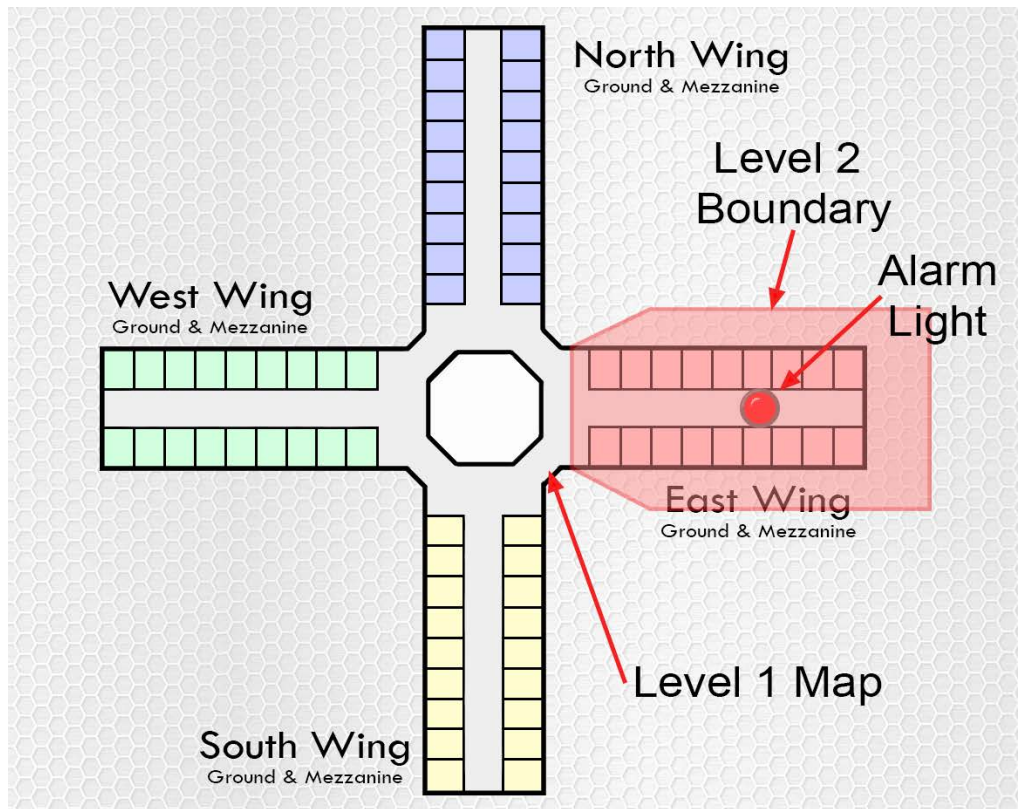

Figure 10 - Level 1 Layout

When used with Level 2 layouts, the Level 1 layout is used to show an overview of the facility. The Level 1 layout will contain links to one or more level 2 layouts. When the mouse is moved over a link to a Level 2 layout, the mouse pointer will change to a pointing finger and a boundary outline will be displayed around the link to the Level 2 layout. Clicking the mouse once or touching the link area on a touch screen monitor, will display the Level 2 layout associated with the area. Level 1 layout will also display a red alarm light if a fixture on the linked Level 2 layout enters an alarm condition (water overuse or flush overflow).

## WMS II Fixtures

### Fixture Types

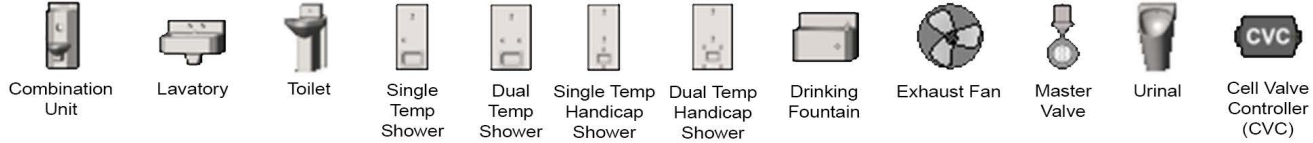

Figure 11 - Fixture Types

*Figure 11* illustrates the different fixture types that may be displayed in the program according to the layout of the actual plumbing fixtures in your facility. Your program will be pre-configured to contain a fixture icon for each actual plumbing fixture connected to the Operator Station via the WMS II network.

The Combination Unit is a combination of a lavatory with hot and cold water and a toilet with a flush valve with an optional overflow sensor. A combination unit consumes 4 inputs and 3 outputs of a Cell Valve Controller (see earlier in this manual).

The Lav icon is a lavatory with hot and cold water.

The Toilet icon is a toilet with a flush valve and optional overflow sensor.

The Shower icon is a single temperature shower with one button and one single temp water valve.

The Dual-temp Shower icon has two buttons and two water valves.

The Handicap Shower icon has one button and one water valve.

The Dual-temp Handicap Shower icon has two buttons and two water valves.

The water fountain icon represents a fountain with a button and a single cold water valve.

The Fan is typically used along with one or more showers. When used as an exhaust fan, the shower is normally configured so that the button on the shower controls both the water valve and the exhaust fan motor.

The Master Valve icon represents an on/off valve for the main water supply for a given area.

The Urinal icon is a urinal with a single flush valve.

Fixture Status

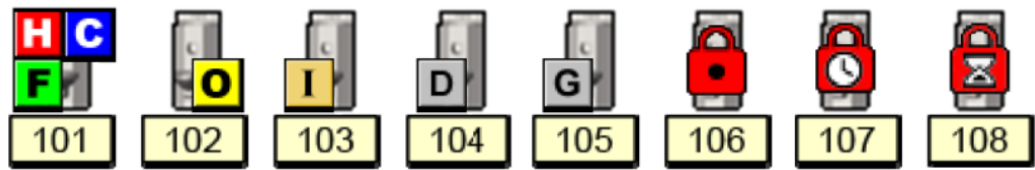

Figure 12 - Fixture Status

Figure 12 illustrates a combination unit in different states. Different symbols are used to represent the different states of the fixture.

Fixture 101 in Figure 12 illustrates the icons used to represent the status of active plumbing valves. The square marked with a “H” represents the hot water valve. The “C” square is displayed for an active cold water valve and the “F” square represents the toilet flush valve. After every flush, the “F” will flash for 10 seconds to allow the flush cycle to complete before another flush can be triggered.

Fixture 102 in Figure 12 illustrates a fixture in a flush overflow alarm state. The square marked “O” will flash on and off to draw attention to the fixture in alarm status. In addition to the fixture overflow display, an alarm window can be displayed explaining the alarm and identifying the fixture in alarm. Also, the Level 1 Floor Plan will display an alarm light in the Level 2 area in which the fixture is located.

Fixture 103 in Figure 12 shows a flush valve is in an initiate delay state state with a square with an “I” displayed. The icon indicates that the function is in a delay period that has been set for the fixture function to occur between the push of a pushbutton by the user and the actuation of the valve. A valve in a delay state cannot be operated by the user until the delay state has ended.

Fixture 104 in Figure 12 shows a flush valve is in reinitiate delay state with a square with a “D” displayed. Valve functions can be in a placed into a delay state when the function is activated and a delay time has been set and the number of valve actuations that may occur before the reinitiate delay is triggered. A valve in a delay state cannot be operated until the delay state has ended.

Fixture 105 in Figure 12 indicates a FlushGuard inhibit is preventing a flush cycle from occurring. This feature when activated will limit the number of flushes that can occur in specified time period on the valve controllers connected to a single network. . Flush “requests” will be stored and issued in the order they were received to perform the requested flushes with the simultaneous flush settings that are set. (Note: This function requires a networked system.)

Fixture 106 in Figure 12 illustrates a fixture in a manual lockout state. A fixture can be manually locked from the Operator Station by using the manual lockout button on the

Control Toolbar (see *Toolbar Commands* in a later section). A manually locked fixture cannot be operated until the fixture is unlocked using the Fixture Reset command from the operator station. (Exception: A fixture function that is in a lock out state may be operated from the Operator Station. The lock out only applies to the pushbuttons at the control.)

Fixture 107 in *Figure 12* is illustrating a fixture in a scheduled lockout period (not in an assigned “Schedule Permit” time period). During a scheduled lockout period, a fixture is completely disabled and cannot be operated with the pushbuttons at the fixture. The scheduled lockout periods can be set or modified using the scheduled lockout button on the Control toolbar (see *Toolbar Commands* in a later section). When the scheduled lockout period ends, the fixture status will return to normal.

Fixture 108 in *Figure 12* is illustrating a fixture in Elapsed Lockout. An operator can configure a one-time lock period for a fixture or group of fixtures. When the time set expires, the lock will be removed and normal fixture operation will resume unless another inhibit function is active. The time period of actuation of this feature is using the Elapse Lockout button on the Control Toolbar. by selecting the fixture, clicking the Elapsed Lock icon from the Control Toolbar. (see *Toolbar Commands* in a later section). An active Elapsed Lockout can be cleared by selecting the fixture and clicking the Reset button on the Control Toolbar.

Fixture Overuse





Figure 13 - Fixture Overuse

The icons shown above are examples of Overuse indication. A fixture is indicated as being in an Overuse condition when a blue droplet appears on top of the fixture icon. The overuse is based on adjustable parameters set and activated by the WMS II program. The icons will alternate between each pattern shown for the type overuse response that has been set for the fixture. A choice of three possible responses can be selected when an overuse is detected.



Notify – Informs the operator that an overuse limit has been reached. Fixture 201 in *Figure 13* shows the two patterns that will alternate on the display screen on a fixture when it reaches the defined overuse condition and when the Notify has been selected as the response to an overuse condition occurring.

 Lockout – Informs the operator and also automatically locks the fixture that has reached its overuse limit. The fixture will remain locked until the operator resets it. Fixture 202 in *Figure 13* shows the two patterns that will alternate on the display screen on a fixture when it reaches the defined overuse condition and when Lock has been selected as the response to an overuse condition occurring.

 Auto Limit – Same as Lockout above except it will automatically clear after sufficient time passes so that the fixture is no longer in the defined overuse condition. Fixture 203 in *Figure 13* shows the two patterns that will alternate on the display screen on a fixture when it reaches the defined overuse condition and when Auto Limit has been selected as the response to an overuse condition occurring.

Note that there can be other icons that partially cover the normal overuse icons when a remote actuation is used from the Operator Station to actuate a fixture function. An example is shown for fixture 204 in *Figure 13*. The blue drop will always be partially visible in these conditions so the operator can know the fixture is in an overuse state and a remote actuation of the fixture has been issued from the Operator Station. (Lock outs can be overridden from the Operator Station.)

### Selecting Fixtures

Most commands used to control fixtures require that one or more fixtures first be selected. The process is to select one or more fixtures and then select a command to apply to the selected fixtures. The following figure illustrates a fixture in the selected state.



Figure 14 - Selected Fixture

The hatched boundary around the fixture indicates that the fixture is selected to receive the next command performed. If a fixture is not displaying the hatched boundary, then the next operation will not affect the un-selected fixture.

To select a fixture, simply click on the fixture using the left mouse button. If a touch screen monitor is being used, the fixture can be selected by touching the fixture once with your finger. Clicking or touching the fixture again will remove the fixture from being selected. Each time that the fixture is touched, the selected state will be toggled on and off.

To select a group of several fixtures, each fixture can be individually selected or the entire group can be selected in one operation by dragging a rectangle around the desired fixtures. To drag a rectangle around several fixtures using a mouse, click the left mouse button at one corner of the rectangle and continue to hold the mouse button down. The cursor will change to a cross-hair to depict that a rectangle is being created. Move the mouse to the opposite corner of the rectangle while continuing to hold the mouse. The boundary of the rectangle will be displayed as the mouse is moved and any fixtures within the rectangle will be selected. Once all fixtures are within the boundary of the rectangle, release the mouse button to select the fixtures. If a touch screen monitor is being used, touch the screen at the starting corner of the bounding rectangle and continue to keep your finger in contact with the screen. Drag your finger across the fixtures to the opposite corner of the bounding rectangle and remove your finger from the screen to select the fixtures.

All of the fixtures on the screen can also be selected at once by using the Select All button on the Control Toolbar (see *Toolbar Commands* in a later section). The Select All button is also used to un-select all of the displayed fixtures if one or more fixtures are currently selected.

## Program Preferences

The WMS II program has several preferences which can be modified for your particular use depending on your security level (explanation on security levels in Chapter 4). The preference settings are grouped into a single configuration command. The Preferences command can be executed by using one of the following options:

**Menu:** Edit | Preferences

**Keyboard:** F2 key

**Toolbar:** Main Toolbar |

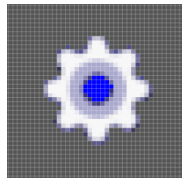

After starting the preferences command using one of the above options, a window with tabbed pages will be displayed. The preferences settings are grouped by pages with similar settings on a page. Each page can be viewed by selecting the tab for that page. Each page is discussed in detail below.

Toolbars

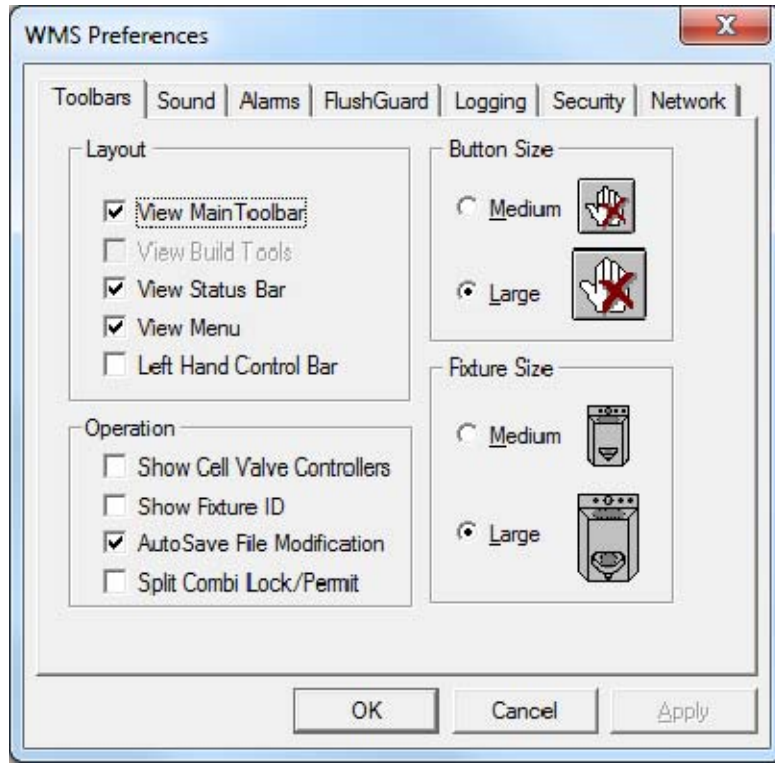

Figure 15 - Toolbars Preferences

The toolbars preferences page contains settings to modify the appearance and layout of the screen. The following settings can be modified:

- **View Main Toolbar:** This check box can be toggled to turn the display of the Main Toolbar on or off. The display of the Main Toolbar can be left off for normal operation.
- **View Build Toolbar:** This check box can be toggled to turn the display of the Build Toolbar on or off (security level required). The display of the Build Toolbar should be left off for normal operation. The use of the Build Toolbar should be limited to Willoughby Industries or Willoughby representatives.
- **View Status Bar:** This check box can be toggled to turn the display of the Status Bar on or off. The display of the Status Bar is on for normal operation.
- **View Menu:** This check box can be toggled to turn the display of the Menu on or off. The display of the Menu should be on for normal operation.
- **Left Hand Control Bar:** This check box can be toggled on to display the Control Toolbar along the left edge of the screen. If this box is not checked,

the Control Toolbar will be displayed along the right edge of the screen. It may be easier for left-handed persons to operate the Control Toolbar on the left side of the screen.

- **Button Size:** The buttons on the three toolbars can be displayed in two different sizes. If the WMS II program is being used with a touch screen monitor, it is recommended that the large buttons be used for easier selection. Select the text or the button for the size of button desired.
- **Fixture Size:** The fixture icons can be displayed in two different sizes. If the WMS II program is being used with a touch screen monitor, it is recommended that the large icons be used for easier selection. Select the text or the button for the size of button desired. (security clearance required).
- **Show Cell Valve Controllers:** This check box can be toggled to turn the display of Cell Valve Controller fixtures on or off. Since the CVC icons do not show fixture operation, it may be desirable to turn off the display of the Cell Valve Controllers.
- **Show Fixture ID:** An optional text box displaying the ID of each fixture can be displayed below the icon for each fixture. The display of the text box can be turned on or off with this check box.
- **AutoSave File Modifications:** This check box toggles on or off the AutoSave option. When the AutoSave option is turned on, any changes to the program will automatically be saved to the file on the hard disk without running the File, Save command. **It is highly recommended that this option be turned on.**
- **Split Combi Lock/Permit button:** The split feature provides the option for combination units (single fixtures containing a toilet and a lavatory) to be treated separately for the locking functions. (There are three locking functions available in the system: Manual Lock, Scheduled Permit/Lock, and Elapsed Lock.) By default, combination units are treated as a single fixture and the lock icon is centered on the fixture. When split, the icon is centered on either the top (lavatory) or bottom (toilet) to indicate which fixture function(s) is (are) locked.



Figure 16 – Single versus Split Combination Unit Lock Icons

In split mode, it is possible for the toilet to be locked and the lavatory unlocked, the lavatory locked and toilet not locked, or both of them to be locked.



Figure 17 – Split Combination Lock Possibilities

Changing to split combination unit mode for locking or vice versa requires a user level of supervisor or higher.

- **OK button:** The OK button saves all preferences settings and closes the preferences command.
- **Cancel button:** The cancel button closes the preferences command without saving any changes made to the preferences settings.
- **Apply button:** The apply button saves all preferences settings, but continues to display the preferences pages.

## Sound

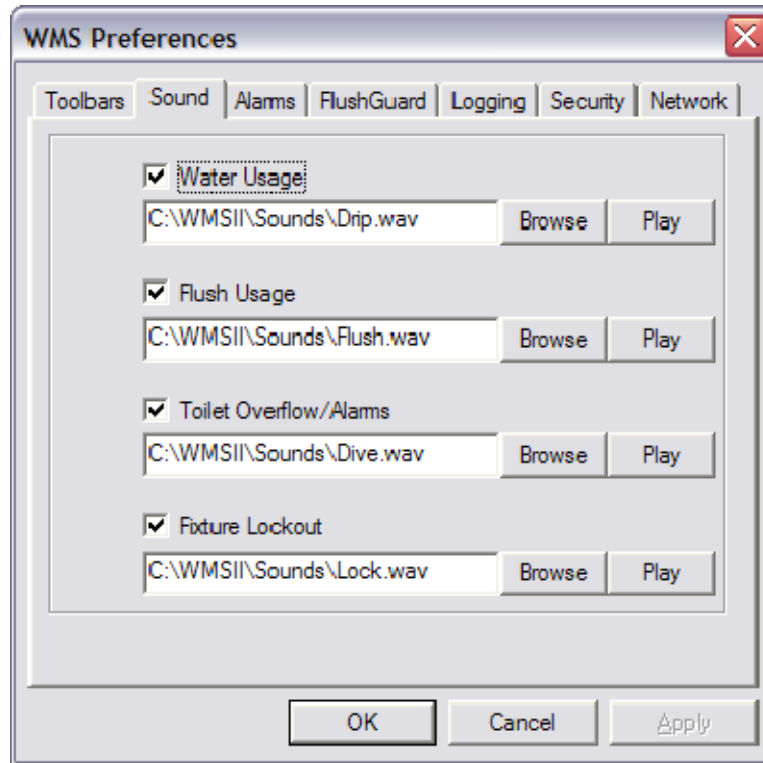

Figure 18 - Sound Preferences

The sound preferences page assigns a sound to certain events so that the sound will be heard whenever that event occurs. Each event contains a check box to turn the sound capability on or off for that particular event. If the event sound is turned on, then a sound file is associated with the event. The file name for the sound can be typed in the provided field, or the **Browse** button can be used to select the sound file. The **Play** button can be used to test the sound. The use of the events is discussed in more detail below:

- **Water Usage:** Turn this event sound on to hear the associated sound whenever a water valve is activated. If turned on, the sound will be heard when a lavatory hot or cold water is turned on, a shower is turned on or a water fountain is turned on.
- **Flush Usage:** This event sound will be heard whenever a toilet or urinal flush valve is activated.
- **Toilet Overflow/Alarms:** This event sound is used whenever a toilet overflows or another alarm occurs. The alarm sound will repeat every time

that the alarm window is displayed unless silenced from the Alarm Window (see *Alarms* in a later chapter).

- **Fixture Lockout:** This event sound is heard whenever a fixture is locked, either manually or automatically using a scheduled lockout.

To turn off all event sounds, toggle all of the check boxes on this page so that they are unchecked.

### Alarms

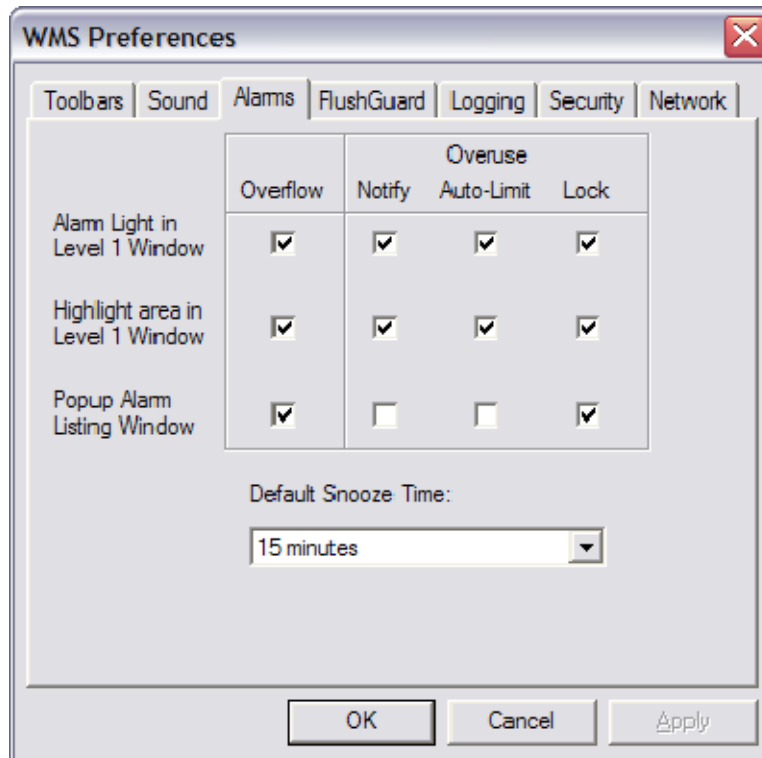

Figure 19 - Alarms Preferences

The alarms preferences page is used to determine what actions will occur when an alarm condition occurs. A further discussion of alarms follows in a later chapter. The alarm preference settings are discussed below:

- **Alarm Light in Level 1 Window:** This check box toggles the display of the alarm light icon on Level 1 floor plans. If this check box is checked on, then an alarm light will appear on the Level 1 floor plan whenever an alarm occurs in a Level 2 fixture. The location of the alarm light will identify which Level 2 floor plan contains the alarm condition.

- **Highlight area in Level 1 Window:** This check box toggles the option to highlight the entire area within the boundary of a Level 2 link on a Level 1 floor plan. *Figure 10* shows a Level 1 floor plan with both the alarm light and the highlighted area options turned on.
- **Pop-up Alarm Listing Window:** This check box toggles the display of the pop-up alarm window whenever an alarm condition occurs. The pop-up alarm window is used to list all of the active alarms as well as identify the fixtures causing the alarms. A more detailed explanation of the pop-up alarm window is contained in the next chapter.
- **Default Snooze Time:** This field is used to set the time interval between the display of the pop-up alarm window. The pop-up alarm window will continue to be displayed, even when closed, at the given interval until the alarm condition is cleared by resetting the fixture. To change the pop-up interval, type in a new setting or use the scroll arrows to change the number of minutes for the pop-up interval.

FlushGuard

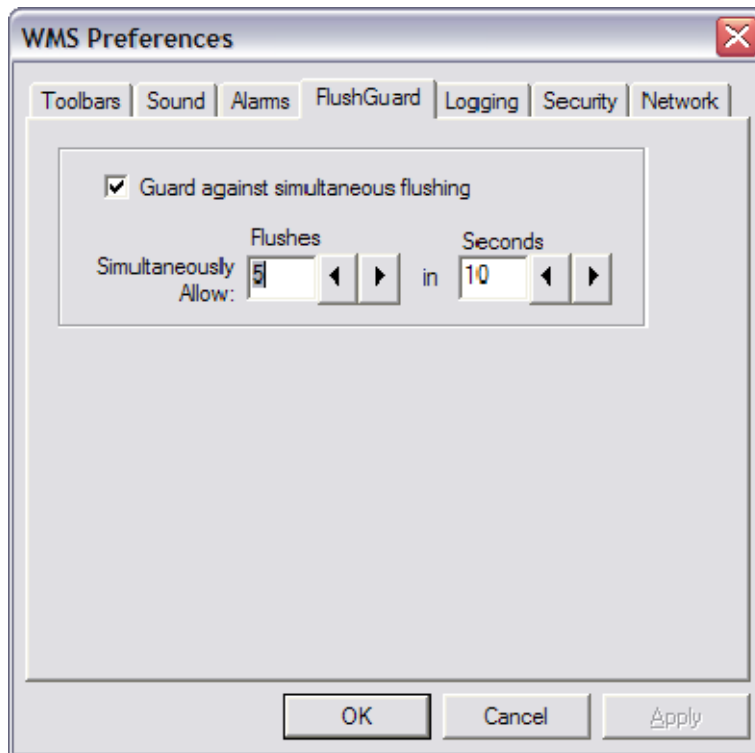

Figure 20 - FlushGuard Preferences

One of the features of using the WMS II Operator Station on the network is the capability to monitor the use of the toilet flush valve and to limit activity of the flush valves on the network in order to prevent simultaneous flushing of several valves at one time. This feature is labeled **FlushGuard** in the WMS II program.

The FlushGuard option can be turned on to limit the number of simultaneous flushes that will be allowed within a specified time period. To turn on the FlushGuard option, select the **Guard against simultaneous flushing** check box on this page so that the check box is checked on.

The other two fields are used to specify the number of flushes that can simultaneously occur within a given time. In the example of *Figure 20*, the WMS II program will only allow four toilets to flush every 10 seconds. If more than four toilets request a flush operation, either from the fixture or from the WMS II program, the first four toilets to request a flush will flush immediately while the other toilets must wait time for the 10 second period to expire when up to four more toilets may be flushed.

To change the number of flushes that can simultaneously occur within the time period, type a new setting into the provided field or touch/click the scroll arrows to change the number of simultaneous flushes. The time period for simultaneously flushing can also be modified – type a new time period in seconds in the provided field or touch/click the scroll arrows to modify the time period. For example, the number of simultaneous flushes could be set to 5 flushes within a 3 second time period. In this example, up to 5 toilets could flush at the same time while any additional toilets would wait in line for the 3 second time period to expire.

## Logging

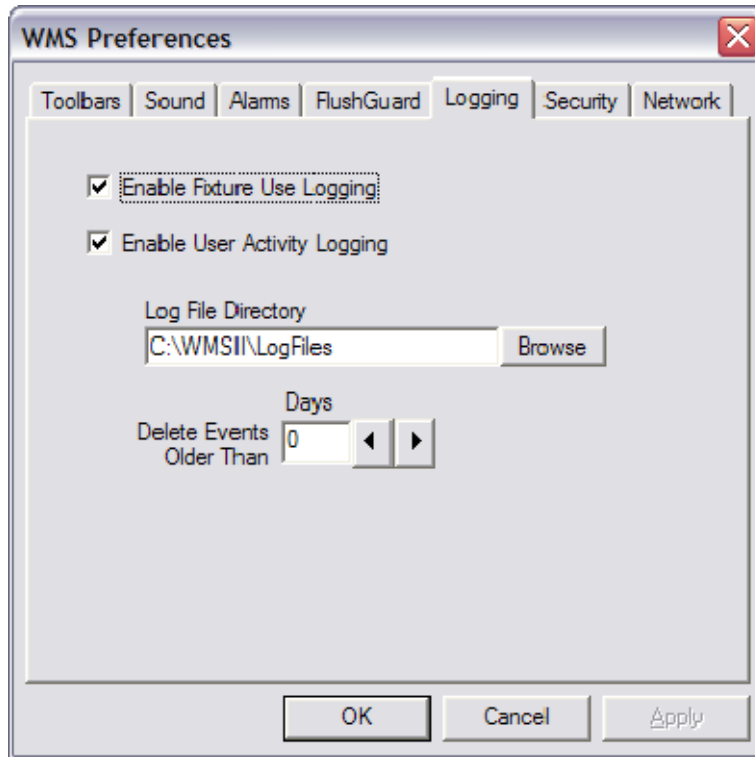

Figure 21 - Logging Preferences

All activity reported to the WMS II program can be logged to a file. The logging preferences page is used to identify the location of the logging database as well as other logging options. The fields on this page are discussed in more detail below:

- **Enable Logging:** This check box controls whether the logging feature is activated. The check box should be checked to enable logging of all activity.
- **Log File Directory:** This field specifies the location on the hard disk where the log files will be located.
- **Delete Events Older Than xx Days:** When all activity is being logged, the log file can grow to a substantially large size. To help control this growth, the logging database can automatically be purged of all activity records older than the specified number of days. The logging database will always contain activity records going back the specified number of days. Type a new value in the provided field or use the scroll arrows to change the number of days to track activity for. **Setting the number of days to zero will disable this option but retain all activity records.**

Two additional tabs are in the preferences setting for security and network. They are covered in detail in the later section on “System Access.”

## Alarms

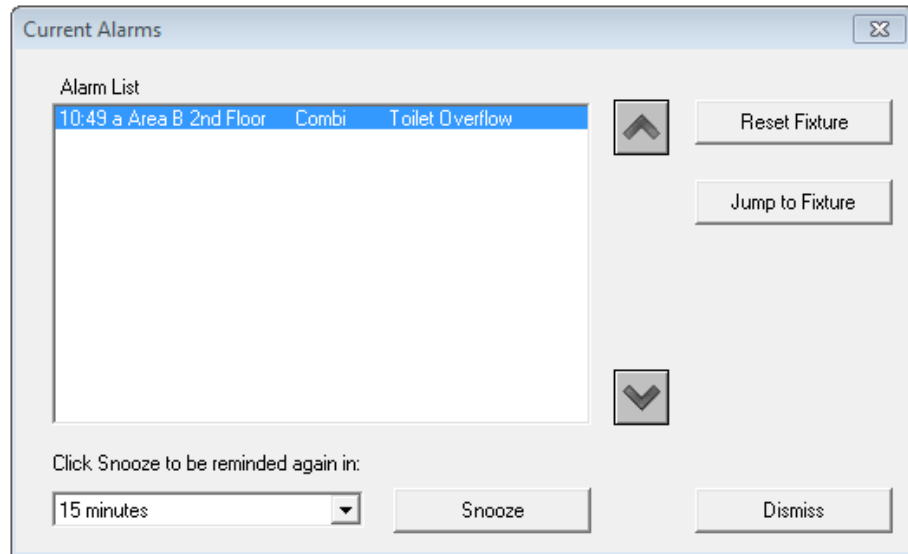

Figure 22 - Pop-up Alarm Window

Displayed in *Figure 22* is the pop-up alarm window that is displayed whenever a new alarm event occurs. The preferences command can be used to turn this option on or off. The pop-up alarm window is displayed on top of all levels and floor plans and will not close until instructed to do so. If the alarm window is closed, but the alarms are not cleared by resetting the fixture causing the alarm, the window will reappear after the configured interval as a reminder that the alarm has not been cleared.

In addition to the pop-up alarm window, the occurrence of an alarm can also display an alarm light at the appropriate location on Level 1. The alarm light will continue to be displayed until all fixtures in the location have been reset to clear the alarm condition. See the *Alarms* page of the *Program Configuration* section earlier in this chapter for instructions on configuring the alarm notification methods.

The pop-up alarm window maintains a list of alarms that identifies the time of the alarm, the level/floor plan location, the fixture ID and the type of alarm. The following types of alarms will cause the pop-up alarm window to be displayed.

- **Water Overuse:** This alarm is generated whenever a valve is activated more than the maximum configured number of uses within a specified time interval. See the *Overuse* page of the *Program Configuration* section earlier in this chapter for instructions on configuring this alarm.

- **Toilet Overflow:** This alarm is generated whenever the overflow sensor of a toilet is activated. The flush valve for the toilet is immediately shut off and disabled from further use until the fixture is reset by the operator.

The controls on the pop-up alarm window and their use are explained in more detail below:

- **Alarm List:** The alarm list displays all of the active alarms with the most recent alarm displayed at the top of the list. The list will display the time of the alarm, the level/floor plan location, the fixture ID and the type of alarm. If more than one alarm appears in the list, only one alarm can be selected at a time. To select an alarm, click on the desired alarm or use the arrow buttons to scroll to the previous/next alarm.
- **Reset Fixture:** The reset fixture button is used to reset the fixture of the selected alarm in order to clear all alarms on the fixture. If the fixture being reset is the only fixture in the alarm list, then the alarm window will be automatically closed after clearing the alarm. This button provides a convenient method to reset the fixture without using the Fixture Reset command (see *Fixture Reset* in a later section of this chapter). The fixture does not need to be located on the displayed floor plan in order to be reset. This allows a fixture to be reset without leaving the level or floor plan being viewed. **Note that alarms are not cleared until the fixture causing the alarm has been reset.**
- **Jump to Area:** The jump to area button provides a quick and easy method to display the fixture that is causing the alarm. Once this button is pressed, the level and floor plan containing the alarm will be displayed on the screen. The pop-up alarm window will continue to be displayed over the top of the floor plan.
- **Silence Alarm:** The alarm event can be configured so that it plays an alarm sound whenever the alarm window is displayed (see the *Sounds* page in the *Program Configuration* section earlier in this chapter). The alarm sound will continue to repeat according to the time interval configured for the alarm window in the *Alarms* page of the *Preferences* command. The silence alarm button can be used to turn off the alarm sound without removing the alarm window from the screen. The alarm sound will not play even if the alarm window is closed and reappears due to not clearing an existing alarm. **Note that the alarm sound will be heard again if a new alarm is generated.** To permanently turn off the alarm sound, turn off the alarm event sound on the *Sounds* page of the *Preferences* command.
- **Close Alarm Window:** The close alarm window button will close the alarm window so that the floor plan beneath the alarm window can be viewed.

**Closing the alarm window does not reset the fixtures or clear the alarms in the alarm listing.** If the alarms are not cleared by resetting the fixtures causing the alarm, the pop-up alarm window will reappear after the configured time interval as set on the *Alarms* page of the *Preferences* command or if a new alarm occurs.

## Command Reference

### File Menu

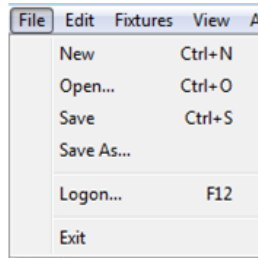

Figure 23 - File Menu

---

**Menu:** File | New  
 File | Open  
 File | Save As...

These commands are reserved for the use of Willoughby Industries. They should not be used for normal operation and could prevent the program from operating normally if used incorrectly.

---

**Menu:** File | Save  
**Keyboard:** Ctrl+S keys  
**Toolbar:** Main Toolbar |

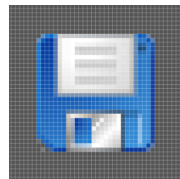

The File | Save command should be used whenever the status bar is displaying the word **Modified**. Certain operations such as changing the timing of a valve cause modifications which require saving. If the *AutoSave* option is turned on, this command does not need to be used as all modifications will automatically be saved.

---

**Menu:** File | Exit  
**Keyboard:** Alt+F4 keys

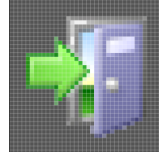

**Toolbar:** Main Toolbar |

The File | Exit command is used to stop the WMS II program. Care should be taken in using this command as closing the program will cease the monitoring of fixtures and could interfere with the normal operation of certain fixtures such as toilets.

Edit Menu

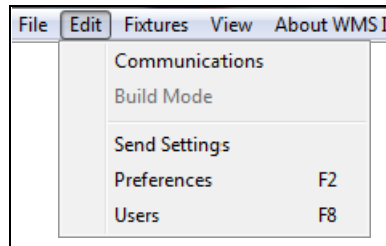

Figure 24 - Edit Menu

**Menu:** Edit | Communications



**Toolbar:** Main Toolbar |

The Edit | Communications should only need to be accessed if communication devices are changed or communication speed is changes on all CVCs on the networks. It requires understanding of the CAN bus interface device(s) and is only accessible at the administrator user level. Consult the manuals and software information supplied for the CAN bus interface device(s) and the manual section in this manual about Baud Rate before attempting to adjust any settings.

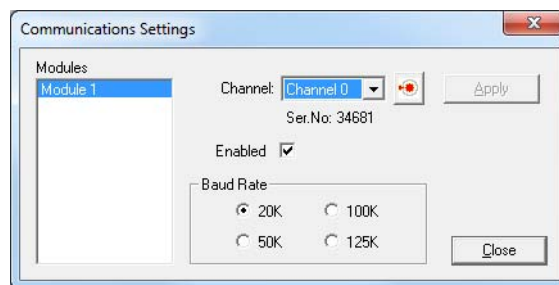

Figure 25 - Communication Settings

The Baud Rate setting in the Communications Settings dialog box must match the DIP switch settings on all of the connected CVCs as described earlier in this manual. It

is recommended that the factory be contacted for assistance by someone with administrator privileges in the software before making any changes in this dialog box.

**Menu:** Edit | Build Mode



**Toolbar:** Main Toolbar |

The Edit | Build Mode should only be used by Willoughby Industries or your Willoughby representative.

**Menu:** Edit | Send Settings



**Toolbar:** Main Toolbar |

The Edit | Send Settings should not be needed as settings in each CVC are maintained automatically by the system, but it can be used to send settings for a selected fixture or group of fixtures manually from the console.

**Menu:** Edit | Preferences

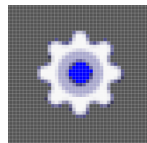

**Keyboard:** F2 key

**Toolbar:** Main Toolbar |

The Edit | Preferences command is used to configure the settings of the program for your particular use. See the *Program Configuration* section earlier in this chapter for a detailed explanation of the preference settings that can be modified.

**Menu:** Edit | Users



**Keyboard:** F8 key

**Toolbar:** Main Toolbar |

The Edit | Users command is used to establish, configure, edit, and delete users of the system. See the *System Access* section later in the manual for a detailed description of using user levels to control access to the program.

Fixtures Menu

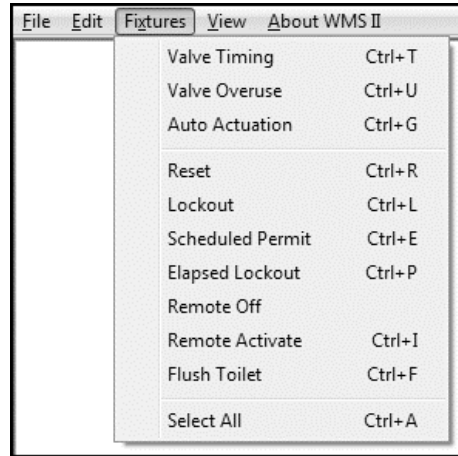

Figure 26 - Fixtures Menu

Numerous choices for configuring and controlling fixture(s) are on the Fixtures Menu. These same items are duplicated on the Control Bar and can also be accessed by selecting the icons on the Control Bar menu or on the drop-down FixturesMenu shown above. (They are described below in the order they appear on the Fixtures Menu.)

---

**Menu:** Fixtures | Valve Timing

**Keyboard:** Ctrl+T keys

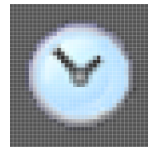

**Toolbar:** Control Toolbar |

The Fixtures | Valve Timing command is used to adjust the length of time that a plumbing valve remains open allowing water flow. **One or more fixtures must be selected before this command will operate.** Each different type of fixture has different timing settings. Therefore, a different window is used for each type of fixture. If more than one type of fixture is selected when using this command, a separate valve timing window will be displayed for each type of fixture. Shown below is an example of the valve timing window for a selected combination unit.

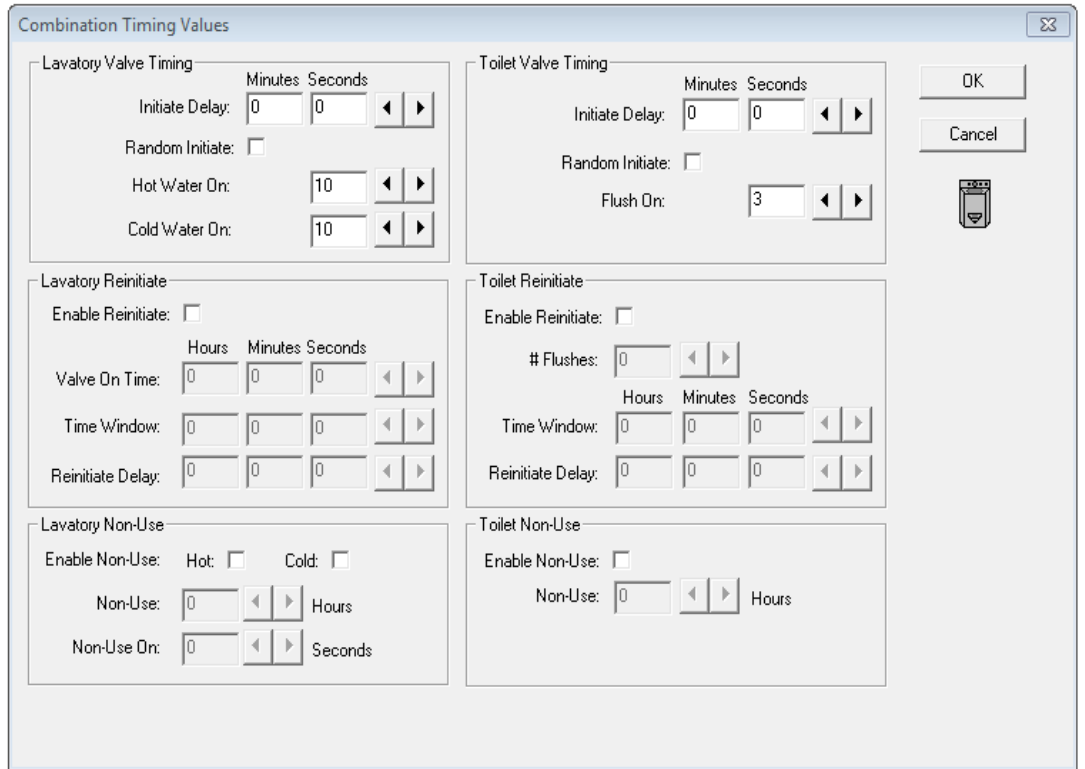

Figure 27 - Valve Timing

The valve timing window for the combination unit contains fields for the activation time of each valve on the combination unit as well as special fields for controlling the flush valve. To change a timing value, type the new time in the appropriate field or press the scroll arrows to adjust the timing up or down. Each of the fields in the above window is described in greater detail below. The valve timing windows for the other fixtures are similar to the Hot or Cold Water timing in the above window.

**Hot Water On:** This field controls the length of time that the hot water valve remains on after being activated. The hot water timing may be adjusted from 1 second to 60 seconds.

**Cold Water On:** This field controls the length of time that the cold water valve remains on after being activated. The cold water timing may be adjusted from 1 second to 60 seconds.

**Flush Valve On:** This field controls the length of time that the flush valve remains on after being activated. The toilet flush timing may be adjusted from 1 second to 10 seconds. Default is 2 sec. for standard flushometers.

**Initiate/Reinitiate:** These fields controls the length of time before and after use of a fixture function that must expire before the toilet may be used again. During this time, the fixture function is considered to be in a delay mode and the fixture icon will display a square with a “D” on it. In addition, the Cell Valve Controller will blink the disabled light for the valve. The initiate timing may be adjusted from 0 seconds to disable this feature to 9 minutes 59 seconds. The reinitiate timing may be adjusted from 0 seconds to disable this feature to 24 hours. Reinitiate delay also allows a number of flushes within a window.

**Non-use:** This field is used to control the length of time since the last activation of the flush valve or water valve that will expire before the valve is automatically activated. This feature prevents the P- trap from drying out during long periods of non-use. If the length of time specified in this field expires without a single activation of the valve, then the Cell Valve Controller will activate the valve. The valve non-use timing may be adjusted from 0 hours to disable this feature to 168 hours (one week).

Similar dialog boxes are available for all fixture types.

**Menu:** Fixtures | Valve Overuse

**Keyboard:** Ctrl+U keys

**Toolbar:** Control Toolbar |

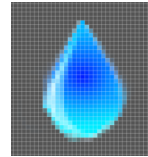

The Fixtures | Valve Overuse command is used to access the configuration dialog box menu of the fixture type selected. Samples of overuse dialog boxes available for fixtures are shown below:

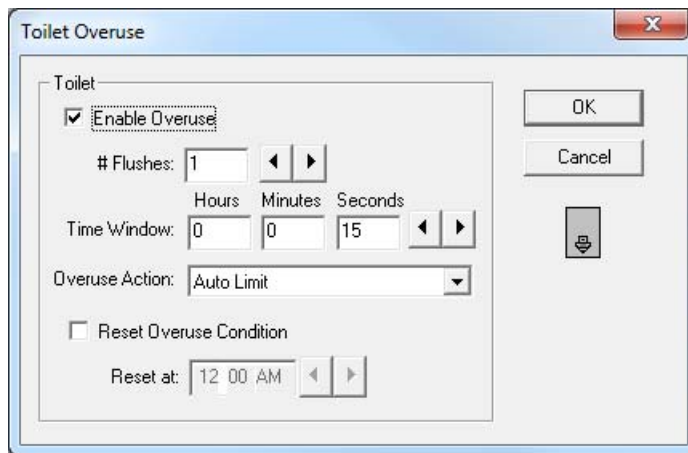

Figure 28 - Toilet Overuse Dialog

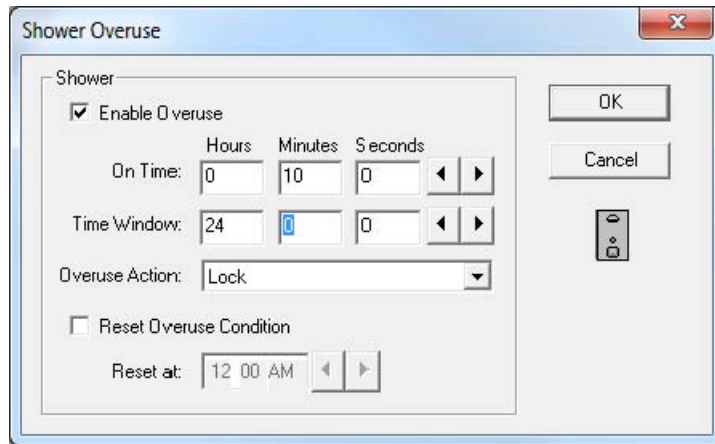

Figure 29 - Shower Overuse Dialog

Similar dialog boxes are available for all fixture types. Refer to *Fixture Overuse* section earlier in this manual for additional details on the overuse feature.

**Menu:** Fixtures | Auto Actuation

**Keyboard:** Ctrl+G keys

**Toolbar:** Control Toolbar |



Fixtures functions can be actuated automatically at set time intervals with this feature. Samples of dialog boxes available for setting auto actuation for fixture(s) are shown below:

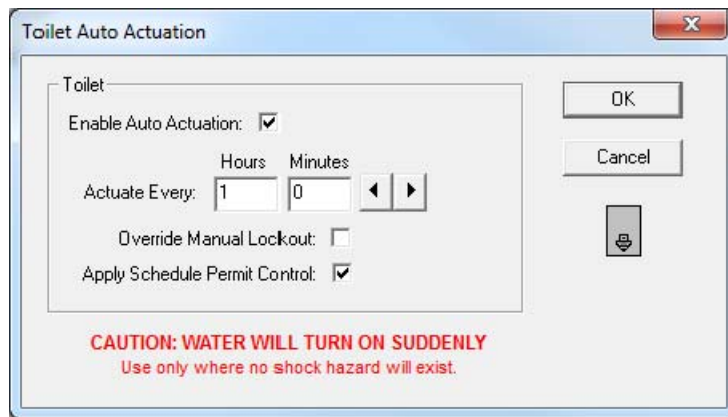

Figure 30 - Auto Actuation Dialog for Toilet

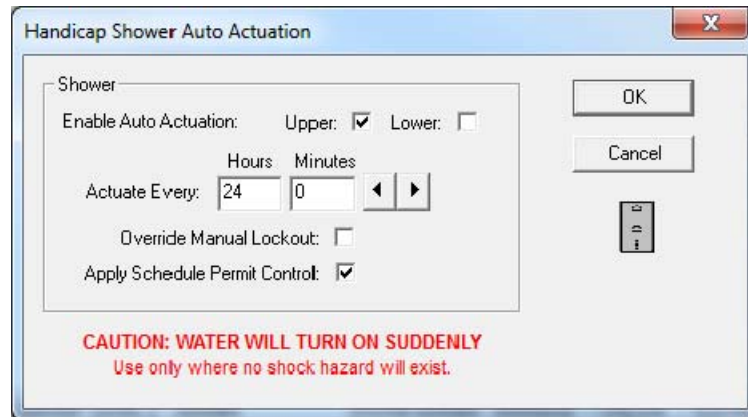

Figure 31 - Auto Actuation Dialog for Handicapped Shower

**CAUTION!** Use this function only when *no* risk is possible of shocking someone with the sudden turn on of water flow on a fixture. It is designed to be used to allow remote control of fixtures when all local control is removed from the user at the fixture. In that scenar, the user will call over the intercom requesting the fixture to be activated.

Several possibilities can be used in conjunction with the locking features of the system with auto actuation, and the check boxes in the dialog box can be selected to either have those features apply or not apply to this function. For example, if the “Apply Schedule Permit Control” is checked, then auto actuate will only function when in a scheduled permit (not locked) period. Auto actuation could be avoided during the night sleep hours using these two features together.

---

**Menu:** Fixtures | Reset

**Keyboard:** Ctrl+R keys

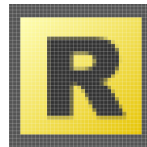

**Toolbar:** Control Toolbar |

The Fixtures | Reset command is used to reset a fixture back to normal operation. The Reset command will cancel all of the following conditions:

- Fixture lockout
- Fixture alarm

**One or more fixtures must be selected before this command will operate.** If a fixture is displaying a key indicating that it has been locked, then this reset command will cancel the lockout and enable the fixture for normal use. A fixture that generates an alarm condition will remain in the alarm mode until reset using this command. If a

toilet overflow alarm occurs, the flush valve on toilet is disabled from all future use until the fixture is reset.

---

**Menu:** Fixtures | Lockout

**Keyboard:** Ctrl+L keys

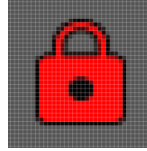

**Toolbar:** Control Toolbar |

The Fixtures | Lockout command is used to manually lock one or more fixtures from further use. The fixture will remain in the locked state until reset using the Fixtures | Reset command. **One or more fixtures must be selected before this command will operate.** All valves on a combination unit are locked together so that a locked out combination unit will prevent both lavatory and toilet use. When a fixture is locked out, all of the status lights for the fixture's Cell Valve Controller will be lit.

---

**Menu:** Fixtures | Scheduled Permit

**Keyboard:** Ctrl+K keys

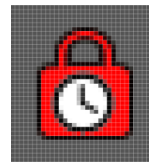

**Toolbar:** Control Toolbar |

The Fixtures | Scheduled Permit command is used to store a time schedule on the Cell Valve Controller that allows a fixture to be used during scheduled periods of the day. **One or more fixtures must be selected before this command will operate.** The Scheduled Permit command is similar to the Fixtures | Lockout command except that the Scheduled Permit will lock and unlock the fixture according to the time schedule stored on the Cell Valve Controller.

The Scheduled Permit command displays a window used to edit the scheduled permit periods for the selected fixtures. The current time schedule is shown when the window is first displayed. Additional time periods may be added to the schedule. The hours or days for an existing period can be adjusted or the time period can be removed from the schedule. An example of the Scheduled Permit window is shown below with a more detailed description of its use.

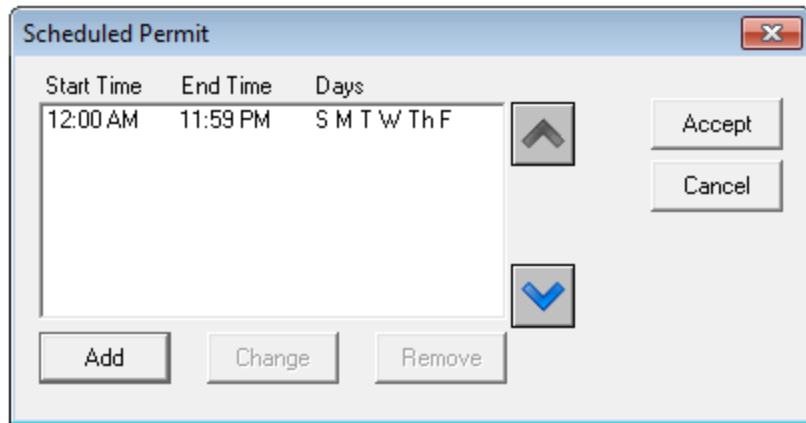

Figure 32 - Scheduled Permit

When one or more fixtures are selected and the **Scheduled Permit** button is pressed, the above page is displayed. This page is used to assign the automatic Scheduled Permit times for the selected fixtures. A permit time is a scheduled period of time when the fixture will operate. This may be used to prevent shower use or toilet/lavatory use during scheduled periods of the day or night. If the first fixture selected has an existing schedule, then the schedule will be displayed in the list on the left.

Each fixture may contain up to 4 scheduled permit periods. Each scheduled period may be associated with a day of the week so that a separate schedule can be used for weekdays and weekends. The list of scheduled times displays the start time, the end time and the days of the week that the scheduled permit time will occur. The scheduled time may cross midnight, as in the above example, in which case the day of the week that the scheduled time is active is always associated with the start time.

To assign a new time period to the list, press the **Add** button and the page displayed in *Figure 33* below will be displayed to allow the entering of a new time period. To modify the start time, the end time or the days of the week for an existing time period, select the time period to change and press the **Change** button. To remove an existing time period, select the time period to remove and press the **Remove** button.

The scheduled permit page will automatically adjust the time periods to make the most efficient use of the 4 allowed scheduled times. For example, if a time period exists as 9:00 PM – 11:00 PM and a new time period is entered as 10:00 PM – 12:00 AM, then the two time periods will be combined into a single time period ranging from 9:00 PM – 12:00 AM. This function also takes into consideration the days of the week and in some case may create an additional time period. For example, if the existing time period ranges from 9:00 PM – 11:00 PM – M T W, and a new time period is entered that ranges from 10:00 PM – 12:00 AM – W Th, then the following periods will exist: 9:00 PM – 11:00 PM – M T, 9:00 PM -12:00 AM – W, 10:00 PM – 12:00 AM – Th. If

when entering a new time period, an additional time period is created or an existing time period is removed, look closely at the time ranges to determine that there is an overlap of time periods and the scheduled permit page combined the overlapping times for most efficient use of the fixture permit feature.

After the scheduled permit periods have been set as desired, press the **Accept** button to assign the scheduled permit periods to the selected fixtures.

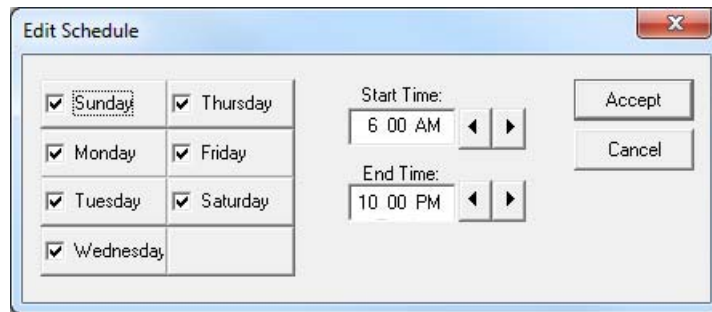

Figure 33 - Edit Schedule

Figure 33 illustrates the page used to add or modify a scheduled time period. The start time and end time can be entered by typing the hours, minutes and AM or PM in the corresponding field. You can use the Tab button on the keyboard to move between the hours, minutes and AM/PM fields. The start and end time can also be changed by using the scroll arrows to the right of each field. The scroll arrows will increment or decrement the time by 15 minute intervals. The longer a scroll arrow is held without releasing the mouse button, the faster the time will change.

The day(s) of the week that the scheduled time period is active can be controlled by selecting the day of the week check buttons. A check to the left of the day indicates that the time period is active for that given day. Pressing a checked day will remove the check mark in order to indicate that the time period is not active for that day.

After the start time, end time and days of the week for the time period have been set, press the **Accept** button to add the time period to the list of scheduled permit times.

---

**Menu:** Fixtures | Elapsed Lockout

**Keyboard:** Ctrl+P keys

**Toolbar:** Control Toolbar |

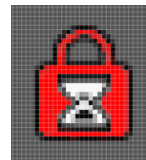

The Fixtures | Elapsed Lockout command will enable configuration of an elapsed timed lockout of selected fixtures. dialog box will appear when the feature is selected to set the time period of the one-time lockout.

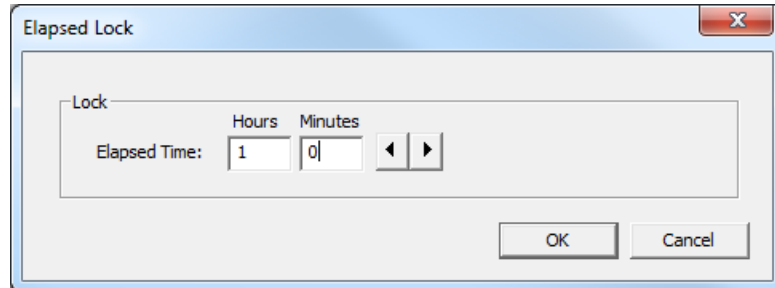

The fixture will be locked out upon clicking “OK” for the period of time that has been set in the dialog box. Upon completion of the time period, the fixture will be automatically unlocked and return to normal use unless another inhibit is active.

**Menu:** Fixtures | Remote Off

**Keyboard:** No keyboard shortcut

**Toolbar:** Control Toolbar |

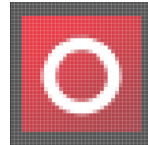

The Fixtures | Remote Off command will abort all selected valve cycles for selected fixtures (except the very short flush valve cycles) remotely from the Operator Station. **One or more fixtures must be selected before this command will operate.** Press the red off button to turn off the fixture functions that are running.

**Menu:** Fixtures | Remote Activate

**Keyboard:** Ctrl+I key

**Toolbar:** Control Toolbar |

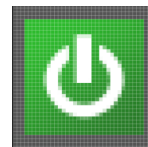

The Fixtures | Remote Actuate command will remotely activate a valve cycle from the Operator Station using the set valve cycle timing set for the fixture that do not involve a flush valve. (Use the “F” flush button to actuate flush valve cycles remotely.) **One or more fixtures must be selected before this command will operate.** Press the green on button to activate the fixture cycle.

**CAUTION!** Use this command only when *no* risk is possible of shocking someone with the sudden turn on of water flow on a fixture. It is designed to be used to allow remote control of fixtures when all local control is removed from the user at the

fixture. In that scenar, the user will call over the intercom requesting the fixture to be activated.

If only one valve is involved in the fixture actuation (e.g., single-temp shower, drinking fountain), the valve will activate immediately when the green icon is clicked. If more than one valve is involved in the fixture actuation (e.g., dual-temp lavatory, handicapped shower), a dialog box will appear where the individual valves that will be turned on remotely are selected. Click “OK” to being the activation of the selected (checked) valves. Examples of dialog boxes for remote activation of fixtures with multiple valve choices are shown below:

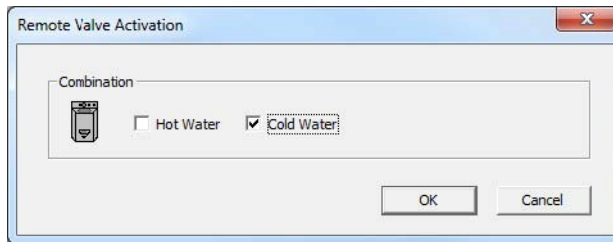

Figure 34 - Remote Valve Activation for Combination Unit Lav



Figure 35 - Remote Valve Activation for Dual-Temp Handicapped Shower

---

**Menu:** Fixtures | Flush Toilet

**Keyboard:** Ctrl+F key



**Toolbar:** Control Toolbar |

The Fixtures | Flush toilet command will flush all selected toilet flush valves remotely from the Operator Station. **One or more fixtures must be selected before this command will operate.** Any selected fixtures which do not have a flush valve are ignored. This command will observe the *FlushGuard* setting when flushing more than one selected toilet at the same time. Therefore, if a selected toilet does not appear to flush immediately and delay icon is on the fixture, it may be waiting for its turn to flush according to the *FlushGuard* setting.

**Menu:** Fixtures | Select All

**Keyboard:** Ctrl+A keys

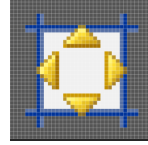

**Toolbar:** Control Toolbar |

The Fixtures | Select All command is used to select all fixtures on the currently displayed layout. Pressing the Select All button once will select all fixtures at once. If there is one or more fixtures that are already selected when this command is run, then all displayed fixtures are unselected instead. This command provides a very quick method to select all displayed fixtures at one time.

View Menu

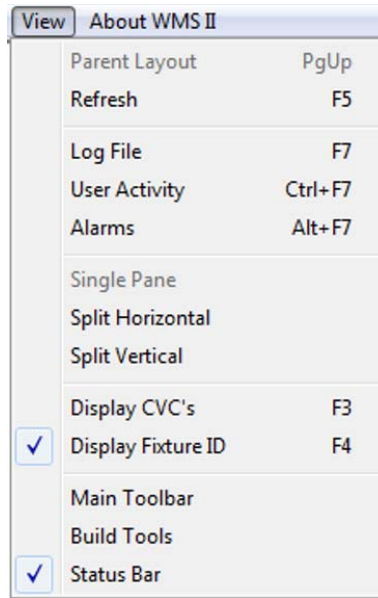
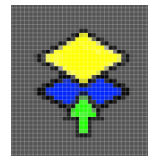

Figure 36 - View Menu

**Menu:** View | Parent Layout

**Keyboard:** PgUp key



**Toolbar:** Control Toolbar |

The View | Parent Layout command is only active when a Level 2 floor plan is being displayed. This command will display the parent Level 1 floor plan in place of the previously displayed Level 2 floor plan.

**Menu:** View | Refresh

**Keyboard:** F5 key

The View | Refresh command will redraw the contents of the current floor plan. If an object is not displaying as you think it should, try using this command to redraw the object.

**Menu:** View | Log File



**Keyboard:** F7 key

The View | Log File command will display the contents of the logging database. **Logging must be turned on in the Preferences command before activity will be logged** (See the *Logging* page in the *Program Configuration* section of this chapter). This command will display a window that lists the activity records from the file. The most recent activity is displayed at the top of the activity list. The View Log window can also be used to clear all activity records from the file. An example of the View | Log File window is shown below along with a more detailed description of its use.

Time	Type	ID	Event	Remote
08:32:31	C	103	Flush Idle	
08:32:30	C	101	Flush Idle	
08:32:18	C	103	Flush On	
08:32:17	C	101	Flush On	
08:32:06	C	103	Lavatory Off	
08:32:04	C	103	Lavatory On	
08:32:02	C	101	Lavatory Off	
08:31:59	C	101	Lavatory On	
08:30:56	C	103	Lavatory Off	
08:30:56	C	103	Flush Overflow	
08:30:56	C	103	Flush Idle	
08:30:55	C	101	Flush Overflow	
08:30:55	C	101	Flush Idle	
08:30:53	C	101	Lavatory Off	
08:30:49	C	103	Flush On	
08:30:47	C	103	Lavatory On	
08:30:45	C	101	Flush On	
08:30:43	C	101	Lavatory On	
08:30:33	C	103	Fixture Online	
08:30:33	C	101	Fixture Online	
08:30:25	C	103	Fixture Offline	
08:30:25	C	101	Fixture Offline	
07:56:19	P	East Wing	Program Start	

Figure 37 - View Log File

**Activity List:** The logged activity records are displayed in the activity list with the most recent activities at the top of the list. Each activity contains the date and time that it occurred, the type of fixture (C=Combination Unit, S=Shower, F=Water Fountain, E=Exhaust Fan, P=Program), the fixture ID and the type of activity or

event that occurred. The arrow buttons located to the lower right of the list can be used to scroll the list of activities up or down.

**Close:** The close button removes the View Log File window from the screen. It does not affect the logging database in any way.

**Clear All:** The Clear All button removes all activity records from the logging database. The deleted records are not saved and can not be retrieved after this button removes them from the logging database.

**Refresh:** The refresh button will regenerate the activity list and add any new activity that has occurred since the window was opened.

**Menu:** View | Single Pane

**Toolbar:** Control Toolbar | 

The View | Single Pane command redraws the contents of the screen using a single floor plan (see below).

**Menu:** View | Split Vertical

**Toolbar:** Control Toolbar | 

The View | Split Vertical command will split the contents of the screen vertically in order to show two layouts at one time. This allows more than one area to be monitored at one time. However, showing two layouts at the same time may reduce the size of the floor plan to the point where it may be difficult to view the fixtures on the layouts.

When two layouts are displayed at the same time, only one layout can be active. The active layout is the one that will accept mouse and touch screen commands. The window pane containing the active layout will be drawn with a highlighted border. To make the other layout the active layout, click the mouse button or touch the screen (touch screen monitor only) anywhere on the other layout.

The divider between the two window panes can be adjusted to make pane larger than the other. To move the divider, click the left mouse button on the divider and continue to hold the mouse button down. If a touch screen monitor is being used, touch the divider and keep your finger in contact with the screen. Drag the divider to

the desired location and release the mouse button or remove your finger from the screen.

**Note:** It may be difficult to select and control fixtures when two layouts are being displayed simultaneously. Remember that only one layout can be active at a time and that a layout must be made active before a fixture can be selected.

---

**Menu:** View | Split Horizontal

**Toolbar:** Control Toolbar | 

The View | Split Horizontal Command will split the contents of the screen horizontally in order to show two layouts at one time. The command operates identically to the View | Split Vertical command except that it creates a horizontal divider between the window panes. See the View | Split Horizontal description for further instructions on the use of this command.

---

**Menu:** View | Display CVC's

**Keyboard:** F3 key

The View | Display CVC's command will toggle on and off the display of the Cell Valve Controller icons on the layouts. If a check mark appears next to the menu item, then the CVC display is currently on and the CVC icons are displayed. The F3 key can be used to quickly toggle the display of the CVC icons on and off. Since the CVC icons do not show any activity, it may be desirable to turn the display of the CVC icons off in order to simplify the appearance of the layouts.

---

**Menu:** View | Display Fixture ID

**Keyboard:** F4 key

The View | Display Fixture ID command will toggle on and off the display of the fixture ID box below each fixture icon. The F4 key can be used to quickly turn on and off the display of the fixture ID boxes. If a check mark appears next to the menu item, then the fixture ID display is currently on and the fixture ID boxes are displayed.

---

**Menu:** View | Main Toolbar

**Toolbar:** Main Toolbar

The View | Main Toolbar command toggles on and off the display of the main toolbar. When the main toolbar is being displayed, a check mark will appear next to the menu item. The main toolbar contains the button displayed above which is an alternative method of turning off the display of the main toolbar. The *Preferences* command can also be used to control the display of the main toolbar.

**Menu:** View | Build Toolbar

The View | Build Toolbar command toggles on and off the display of the build toolbar. When the build toolbar is being displayed, a check mark will appear next to the menu item. The *Preferences* command can also be used to control the display of the build toolbar.

**Menu:** View | Control Toolbar

The View | Control Toolbar command toggles on and off the display of the control toolbar. When the control toolbar is being displayed, a check mark will appear next to the menu item. The *Preferences* command can also be used to control the display of the control toolbar.

**Menu:** About

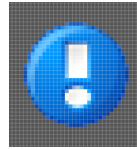

**Toolbar:** Main Toolbar |

The About command displays a window that contains program information such as revision number and copyright information. An example of the About window is shown below.

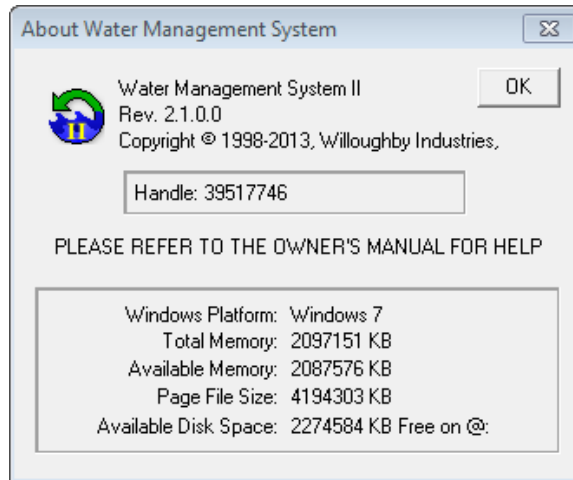

Figure 38 - About Window

---

## Display Fixture Properties

**Action:** double click on a fixture (double tap for touch screen)

The properties of a single fixture can be displayed by double clicking the left mouse button or double tapping the touch screen on a single fixture. This operation does not use selected fixtures since the properties can only be viewed for one fixture at a time. The property window for the fixture contains information such as the Cell Valve Controller ID it is connected to, the current locked state of the fixture, the current state of the plumbing valves on the fixture, the alarm state of the fixture and the cycle settings for each plumbing valve. Additionally, the property window for Cell Valve Controllers will display the serial number and firmware revision number of the CVC.

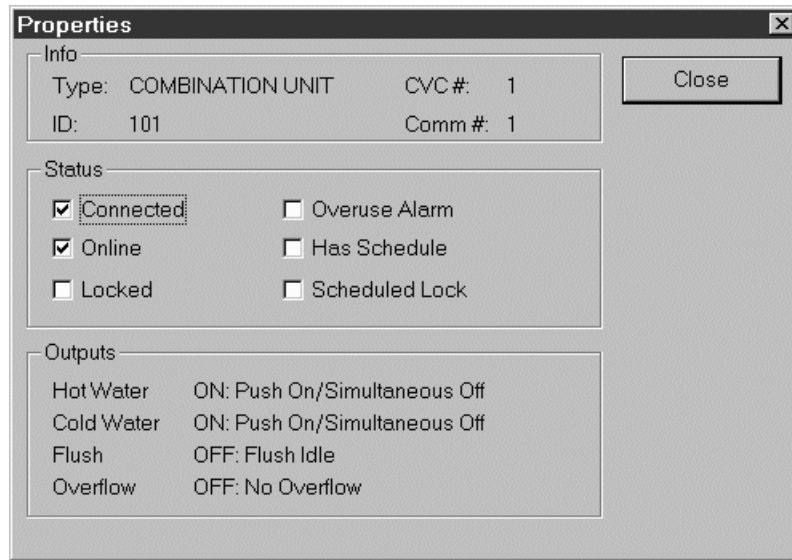

Figure 39 - Fixture Properties

Figure 39 shows an example of the property window for a combination unit. The items contained on the property window are explained below.

- **Type:** This item will display the type of the fixture, such as combination unit, shower, etc.
- **ID:** This item is the fixture ID that is displayed in the box below the fixture.
- **CVC #:** This is the ID number of the Cell Valve Controller that the fixture is connected to. Each CVC has an unique identifying number.
- **Comm #:** This is the communications module that the Cell Valve Controller is connected to using the CAN bus network. The communications module settings are preset at the factory and should not need to be modified.
- **Status:** This section shows the status of the fixture. If a status item is checked, then the corresponding state is active. For instance, if the **Locked** state is checked, then the fixture is currently disabled. If the Operator Station is successfully communicating to the fixture, then the **Online** state will be checked.
- **Outputs:** The outputs section lists the On/Off state of each valve on the fixture as well as the programmed cycle that dictates the operation of the valve.

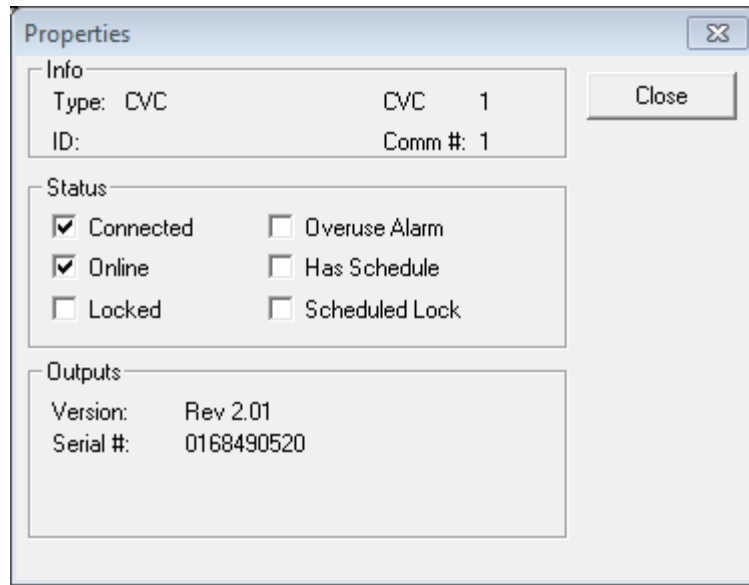

Figure 40 - CVC Properties

Figure 30 shows an example of a property window for a Cell Valve Controller. The items on the CVC property window are identical to the fixture items discussed above with the exception of the **Outputs** section which is explained below.

- **Outputs:** The outputs section on the CVC property window displays the firmware revision number and the serial number for the Cell Valve Controller.

## Pop-up Menus

If a mouse is used for input on the Operator Station, then the pop-up menu feature can be used. This feature is not available when using a touch screen monitor. The pop-up menu provides a method to perform an operation on a fixture without first selecting it.

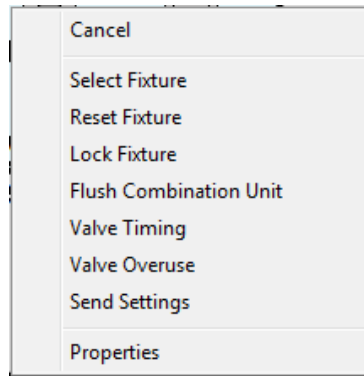

Figure 41 - Pop-up Menu for Fixtures

To activate the pop-up menu for a fixture, click the right mouse button on the fixture that you wish to control. A menu similar to *Figure 41* will be displayed near the mouse cursor. The menu will list the available commands for the fixture. The **Cancel** item is used to remove the pop-up menu without selecting a command to perform on the fixture. Use of the commands on the menu is discussed elsewhere in this manual.

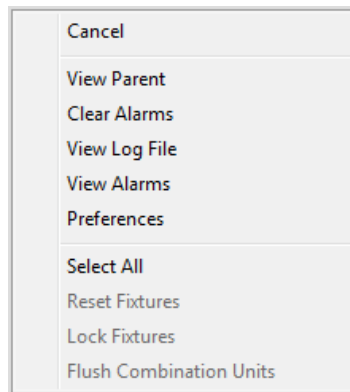

Figure 42 - Pop-up Menu for Floor Plan

If the right mouse button is clicked on a location that does not have a fixture (anywhere else on the floor plan), a floor plan pop-up menu will be displayed similar to *Figure 42*. The commands on this pop-up menu are discussed elsewhere in this manual. The last three commands (Reset, Lock and Flush) are available only when one or more fixtures are currently selected and will perform the requested operation on all selected fixtures.

## How Do I . . .

This section will offer step-by-step instructions for some of the most common operations that will be used on the WMS II Operator Station. The actions to perform assume that the Operator Station is equipped with a touch screen monitor. If a mouse is being used instead of the touch screen, click the left mouse button wherever it says to touch the screen.

### Lock a fixture

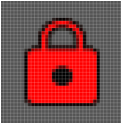
Operation	Action
Select the fixture to lock Or Select several fixtures within a bounding rectangle	Touch the fixture icon  Touch corner of rectangle, drag finger to opposite corner, remove finger from screen
Lock the Fixture	Touch the Lock button 

### Assign scheduled lockout times

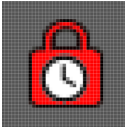
Operation	Action
Select the fixture to lock Or Select several fixtures within a bounding rectangle	Touch the fixture icon  Touch corner of rectangle, drag finger to opposite corner, remove finger from screen
Timed Lockout Command	Touch the Timed Lock button 
Add a new lockout time	Touch the Add button
Select the days that the fixture will be locked	Touch a checked day to remove it from the schedule or touch an unchecked day to add it to the schedule
Set the starting and ending time for the period	Touch the scroll arrows to change the time by 15 minute intervals, or touch the field to change and type a new value.
Accept the scheduled period	Touch the Accept button
Accept the fixture lockout schedule or repeat to add more scheduled periods	Touch the Accept button

Unlock a fixture

Operation	Action
Select the fixture to unlock Or Select several fixtures within a bounding rectangle	Touch the fixture icon  Touch corner of rectangle, drag finger to opposite corner, remove finger from screen
Unlock the Fixture	Touch the Reset button 

Flush a toilet remotely

Operation	Action
Select the fixture to lock Or Select several fixtures within a bounding rectangle	Touch the fixture icon  Touch corner of rectangle, drag finger to opposite corner, remove finger from screen
Flush the Toilet	Touch the Flush button 

Change the timing of a valve

Operation	Action
Select the fixture to lock Or Select several fixtures within a bounding rectangle	Touch the fixture icon  Touch corner of rectangle, drag finger to opposite corner, remove finger from screen
Display valve timing window	Touch the Valve Timing button 
Enter a new time interval for the valve.	Touch the scroll arrows next to the valve timing to change or touch the timing field to change and type a new time interval for the valve to be activated.
Save new valve timing	Touch the OK button to save the new valve timing and send the changes to the Cell Valve Controller.

View a Level 2 floor plan

Operation	Action
The current view must be the Level 1 overview.	Verify that the status bar displays <b>Level 1</b> . If not, return to Level 1 as explained in the next instruction.
Select the desired Level 2 link area	Touch the area on the Level 1 overview that represents the link to the desired Level 2 floor plan. If a mouse is being used, the boundary for the link area will be shown when the mouse is within the link area.

Display the Level 1 overview

Operation	Action
The current view must be a Level 2 floor plan.	Verify that the status bar displays <b>Level 2</b> . If not, you are already at the Level 1 overview.
Return to parent Level 1 overview.	Touch the View Parent Layout button 

Select all fixtures on the floor plan

Operation	Action
At least one fixture must be displayed on the active floor plan.	Verify that fixtures are displayed on the floor plan. If two panes are simultaneously displayed on the screen, verify that the proper floor plan is active by touching the floor plan containing the fixtures to select.
Select all fixtures	Touch the Select All button 

Reset a toilet overflow alarm

Operation	Action
Select the fixture for which you wish to clear the overflow alarm  Or Select several fixtures within a bounding rectangle	Touch the fixture icon  Touch corner of rectangle, drag finger to opposite corner, remove finger from screen
Reset the fixture to clear the alarm	Touch the Reset button 
Or...	
To clear the alarm from the popup alarm window	Touch on the alarm to clear or use the arrow buttons to select the alarm. Touch the Reset Fixture button to clear the alarm.

Reset a water overuse alarm

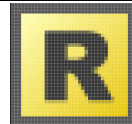
Operation	Action
Select the fixture for which you wish to clear the overflow alarm  Or Select several fixtures within a bounding rectangle	Touch the fixture icon  Touch corner of rectangle, drag finger to opposite corner, remove finger from screen
Reset the fixture to clear the alarm	Touch the Reset button 
Or...	
To clear the alarm from the popup alarm window	Touch on the alarm to clear or use the arrow buttons to select the alarm. Touch the Reset Fixture button to clear the alarm.

NETWORKED MODE OF OPERATION

## System Access

Access to the system is controlled via the use of security levels established for users and the hardware that is employed to access the system. WMS II access is controlled from within the program, so *no* additional restrictions should be imposed through the operating system. Any restrictions are likely to override WMS II functions and render the system not fully usable, and in worst cases, may cause it to malfunction. If operating system restrictions are established at the operating system level, those working with the WMS II should be given administrator privileges in order to permit them to operate and perform any desired functions or modifications to the system.

Similarly, caution should be used in adding programs to the system beyond the ones with which the system was delivered. Common desktop programs such as word processors and spreadsheets in typical use are not a problem. If problems develop when programs are added, be prepared to set the system back to its original state. WMS II is a real-time system, and it uses both hardware and other system resources in a way greater than most software, so it also needs unfettered access to them.

### Security Levels

User levels are utilized to control who has access and privileges to operate and make changes to the system. There are five user levels in WMS II. They are:

No.	User Level	Description
1	View	Limited to viewing only – no actions can be executed
2	Operator	Can initiate locks, resets, of alarms, and remote control of fixtures
3	Supervisor	Can alter system settings for individual fixtures and system-wide users
4	System Admi	Can set up new users with passwords and delete users
5	Builder	Can build new system with graphics and placement of fixtures (reserved for manufacturer's use)

Figure 43 - WMS II User Levels

## SYSTEM ACCESS

Levels are listed above in order from least-privileged user to most-privileged user.

If logged into the system at a SYSTEM ADMIN-level user, current users assigned in the system can be observed by accessing the Users menu on the Edit drop down menu

or  from the Main toolbar. From this dialog box new users can also be established, or existing users edited or deleted.

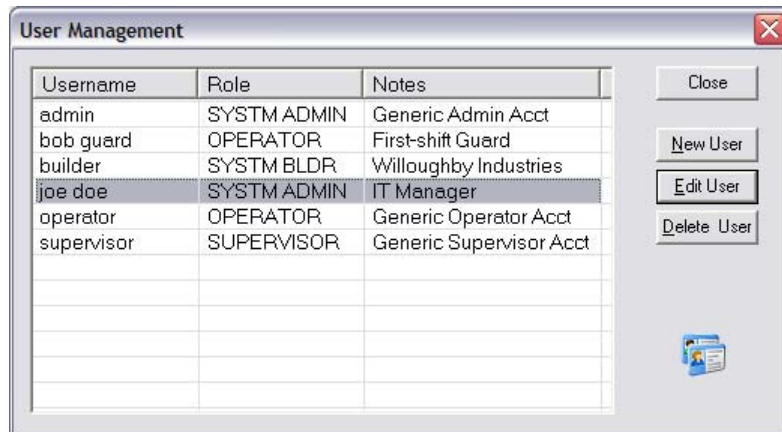

Figure 44 - User Management Window

To edit or delete, the user to be altered must be first selected (show by item being highlighted as show in *Figure 44*), and the dialog box as shown in *Figure 45* will appear.



Figure 45 - Creating New User Account

User names and passwords should be retained in a secure place. In the event, that user names and passwords are forgotten; passwords can be reset and other edits made to user accounts by a user with WMS II administrator or high security level. If all user information is lost, contact the factory for assistance in regaining access to the system.

Passwords can be given a time range of up to 60 minutes, after which they Operator Station will revert to its default level. This is an additional security feature provided in the system to limit the exposure of a person being called away from the Operation Station and failing to log out.

For maximum security, all users should log out if they have logged in to one of the higher levels. If the time out value is set to zero, the time out feature is disabled. This feature should be used sparingly, but it may have value in special circumstances. Time outs may be adjusted for the user level of the current log on and below.

### Security Preferences

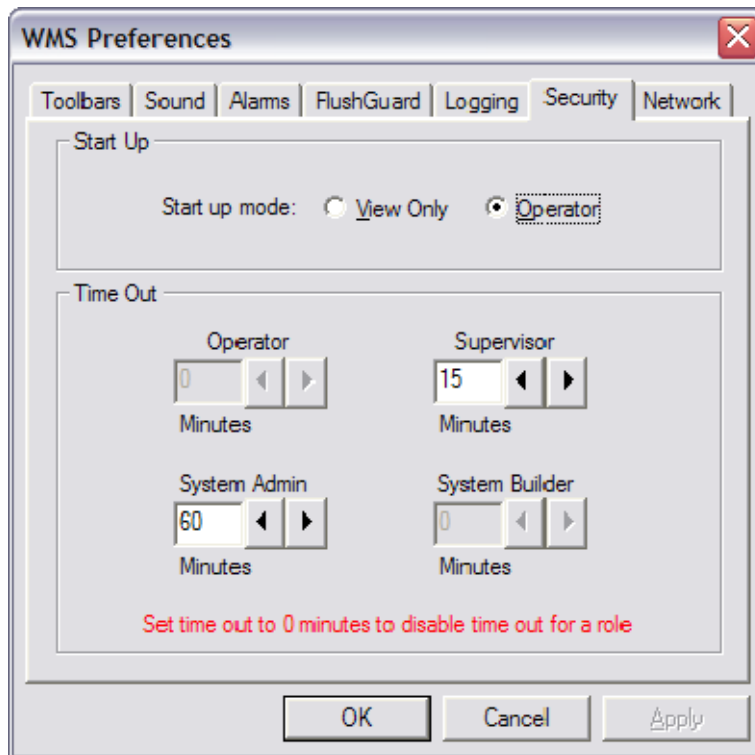

Figure 46 - Security Level Time Outs

One additional feature that can be set the Security tab of the WMS Preferences dialog box is the default mode in which the system launches. Typically, systems are launched in Operator mode where system tasks re performed from a central control room.. However, if higher security is desired, the system can be set to launch in View Only mode. In this mode, only the screen can be observed and no actions can be executed on this system. This setting will also affect whether an operator level can be set up in the user administration screens described earlier. Operator level security can only exist if the system launches in View mode.

NOTE: To properly operate and troubleshoot a WMS II system, the user on the server must have administrative privileges. Before calling the factory for support, ensure that you have administrative privileges on the PC server running WMS II software. Without it, key features within the software will not be useable.

## WMS Clients Option (Multiple Work Stations)

WMS II in a networked configuration requires a minimum of one PC (a server) connected via a network to individual CVCs (up to 127 of them on single network with multiple networks are possible). It may also have additional PCs connected to the system via a client connection over an Ethernet network connection (typical office network connection). There can be up to ten clients connected to a WMS II server at any time. Whether clients will be allowed and the maximum number allowed on a given system is set in the Network tab of WMS Preferences. See *Figure 47*. (The system can be set to have up to 10 clients.)

Since this is an optional feature configured by the factory, all settings are grayed out, but they show which option network options are enabled and how many connections of each kind may be made to the WMS II server.

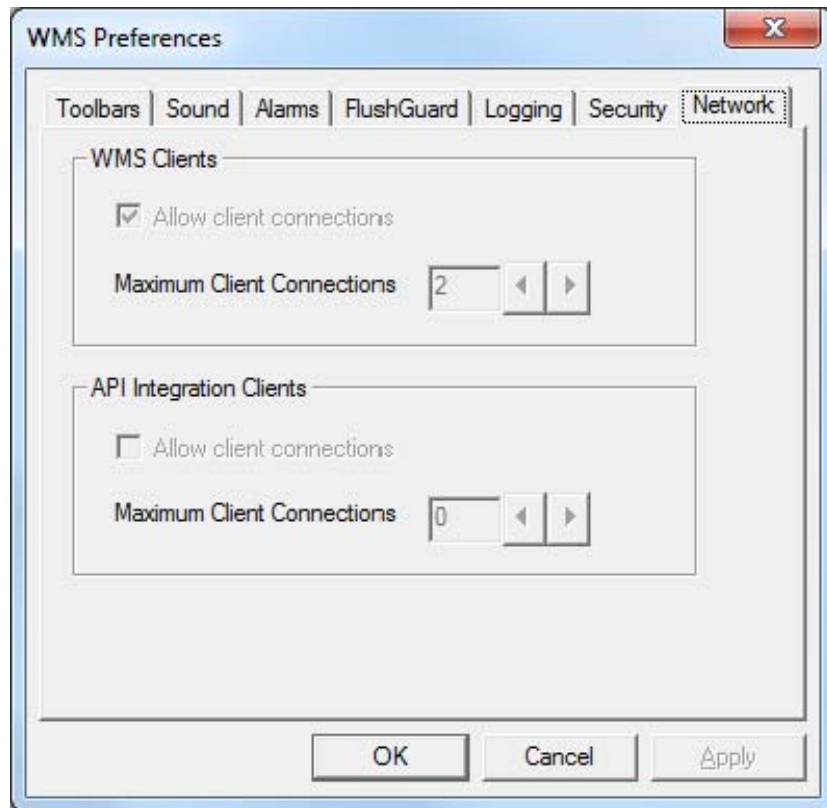

Figure 47 - Network Preferences – WMS Clients

A WMS II client will duplicate nearly all functions (except system build functions and system start and stop). To the end user, the software running on a client PC will have the same appearance and capability as the WMS II software running on the WMS II server. Once a client connection is established to the WMS II server, the client PC will reflect everything on the server PC and any actions taken on the client PC will be communicated and executed on the server PC. All communication with individual CVCs is always performed from the server. All files specific to the installation are also maintained on the server.

This feature enables the additional flexibility of different points of access to the system where different level users may access the system from more than one location.

#### Client Access to the WMS II Server

When booting WMS II from the server, the software starts as any other software -- usually by clicking on an icon to start the software. On a client, a run string is required that contains the IP address of the server to which connection is to be made. Consult with your IT professionals to determine the IP address of the server. Start the WMS II program (wmsII.exe). Then add the following run string to the path and file name of the shortcut program. An example is shown below of using a shortcut with the additional parameters added:

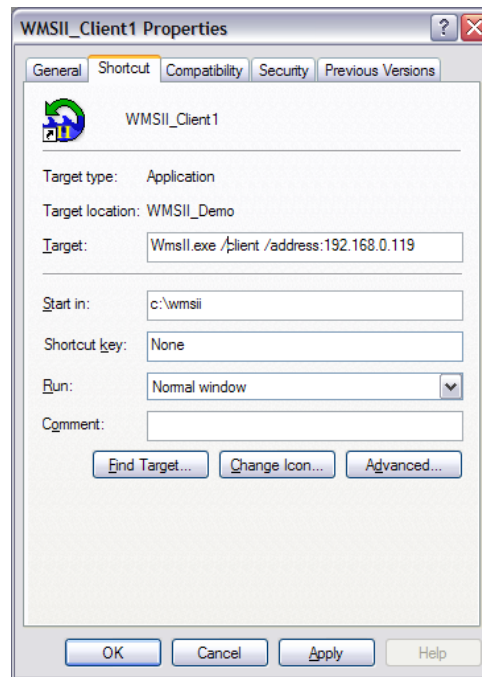

Figure 48 - Shortcut for Client

Note that this is only an example as each computer's IP address will vary and the path names of the associated files may be also different.

Stopping Clients and the Server Remotely

If more than the WMS II Server is on the system, the dialog box shown in *Figure 44* will have an additional “Logged On” button on it as shown in *Figure 49*.

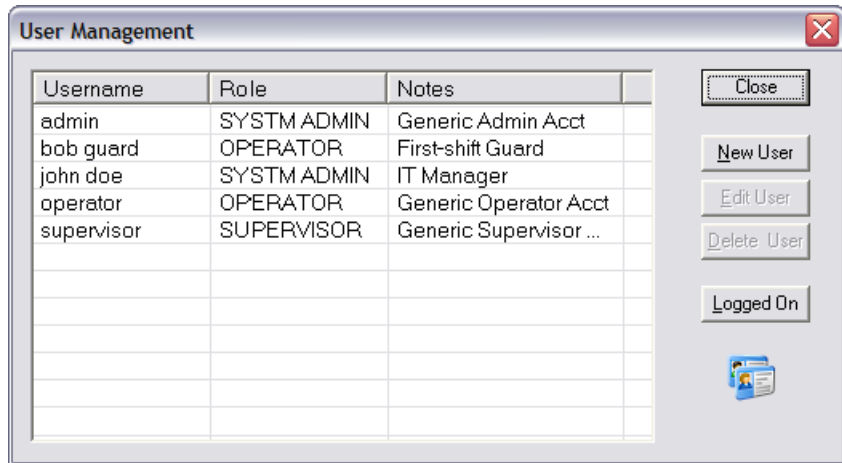

Figure 49 - User Management Window with Clients

By clicking the “Logged On” button, a “Logged On Users” dialog box will appear where individual clients can be selected to “Shut Down.”

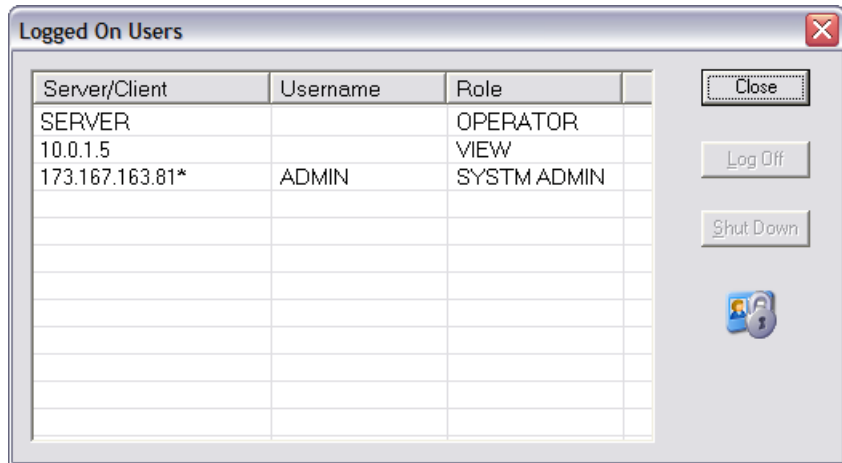

Figure 50 - Logged on Users

The active users and current security level for each session is shown for the Server (identified by “SERVER”) and each of the clients. By clicking on the line of the logged on user, buttons to the right will be enabled to show which functions can be performed on that session. An asterisk will appear beside the session of the PC on which you are currently accessing the system. If enabled, a client can have the “Log Off” function applied to them which will log them off to the lowest security level for

which they are set – either View or Operator. It will not shut down the session. Additionally, a session can be “Shut Down” completely. If “Shut Down” is attempted for the Server, a warning screen will appear because if the Server is shut down, it will typically require going physically to the server PC to restart it. Do NOT shut down the Server unless you are certain that is what you want. All network connections from all clients will also be lost if the Server is shut down. Shutting down the Server stops all network activity and all clients.

The only way to shut down the software for the PC on which you are operating is to close the program by click the “X” in the upper right-hand corner of the program window or by accessing the File menu and selecting the Exit choice.

### Thinking Security

Each facility will vary based on its layout and the establishment of its own policies and procedures, but a few recommendations for considerations are given below.

1. Place the WMS II server in a secure location.

In single PC systems, the WMS II server is typically placed in the guard station to provide the simplest configuration and to parallel hardware to the location of the people who will be using it most frequently. That generally works well, but the client-server capability provides other options for leveraging the system to cope with a situation where control of the guard station may be compromised. In such a situation, it may even be desirable to disable the PC in the guard station. Client-server makes that possible.

2. Use a WMS II client at the guard station.

In most facilities, the control station where most of the system operation will occur is not the most secure location. With the client-server capability where there can be more than one point of PC access to the system, the WMS II server can be placed away from the typical control station in a highly secure location, and the system could be operated via a client PC placed in the guard station. This provides the opportunity to place the essential elements of a WMS II system, the PC, the network, and the controllers in highly secure areas. All other elements become less essential and can be disabled if necessary and control performed either from the WMS II server or establish from other points in other areas where a client connection could be made. If you can foresee a situation in which you would desire to make the control access non-functional in the guard station and yet have the system working, use a client PC. In addition, if you can foresee a situation in which you would desire to access the system from another location, place a client PC at that location. Anywhere you can place an accessible node on your computer network is a place a WMS II client could potentially be placed. With client-server technology, you no longer have to place the most critical elements of the system on a single PC in the guard station or main control room.

### 3. Have a plan.

Generally, the more surprising a compromise of a system is, the less likely people will have the presence of mind to respond appropriately to it; so creation of a plan and practice of the plan is a major part of being able to utilize the security features of the system to the fullest in the event of an unexpected breach of security. Imagine worst case scenarios and determine and document the steps to be taken in that scenario by leveraging the capabilities of WMS II.

## WMS API Integration Clients Option

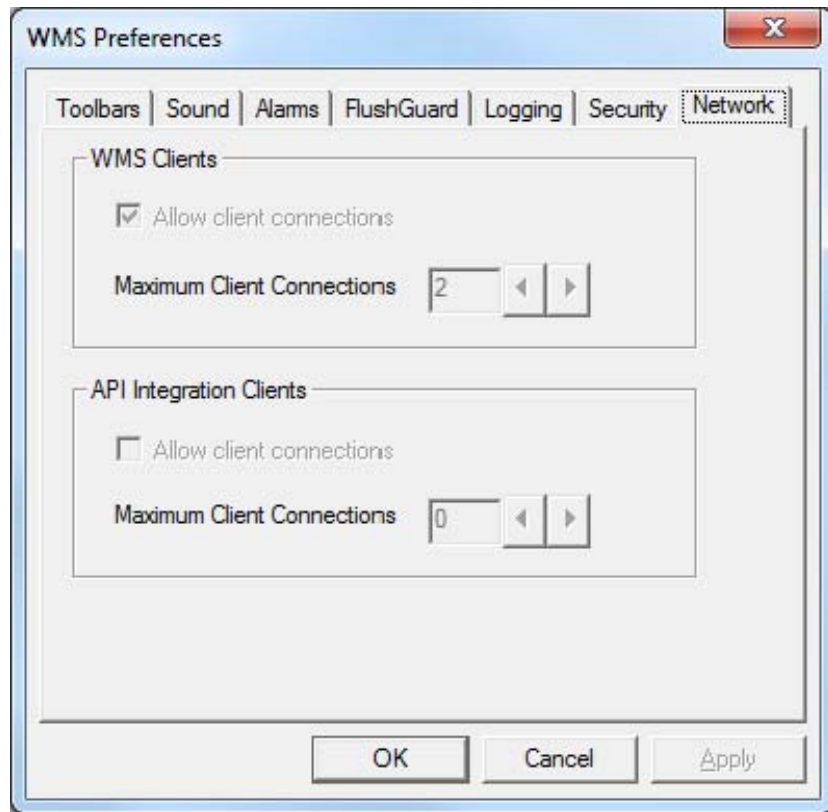

Figure 51 - Network Preferences – API Integration Clients

This option is beyond the scope of this manual except to indicate that an option is also available for the WMS II Server to be integrated into third-party security systems that can control multiple systems (doors, lights, HVAC, etc.) in addition to plumbing from a central operator interface. The Preference | Network dialogue box will indicate if the feature is enabled on a system. Support for the final integration is provided by the third-party system integrator. Contact the factory for details on this option and for references to vendors of central security electronics systems that either have integrated or are willing to integrate WMS II into a larger facility control system.

# Index

## A

About .....	58
active .....	56
active plumbing valves.....	26
Add.....	49
Administrator (Security Level) .....	68
alarm .....	38
alarm light .....	34, 38
alarm list .....	39
alarm window.....	35
alarms.....	34
Alt+F4 .....	41
AM.....	50
Auto Actuation.....	46
AutoSave.....	31, 41

## B

Build Toolbar .....	23, 30, 57
Builder (Security Level).....	68

## C

CAN bus .....	9, 13
Cancel .....	61
Cell Valve Controller (CVC)	
communication light .....	12
description.....	9
diagnostic light, green.....	10
diagnostic light, red.....	10
diagnostic lights .....	12
diagnostic pushbuttons.....	10
DIP switches .....	13
heart beat light.....	12
input light.....	12
output lights .....	12
overflow reset.....	13
Plumbing fixture connections .....	9
power light .....	12
RS-485 connections .....	13
Central Computer.....	19
icon.....	20
start.....	20
Change .....	50
clear.....	38
Clear All.....	55
client.....	74
client access .....	72

Client Access.....	72
client connection .....	71
Client-server .....	71
close alarm window.....	40
cold water .....	44
combination unit.....	9, 25
Control Toolbar .....	22, 58
Ctrl+A .....	53
Ctrl+F .....	53
Ctrl+G .....	46
Ctrl+I.....	52
Ctrl+K .....	48
Ctrl+L.....	48
Ctrl+P .....	51
Ctrl+R.....	48
Ctrl+S .....	40
Ctrl+T.....	43
Ctrl+U .....	45

## D

day of the week .....	50
disabled .....	10, 39
Display CVC's .....	57
Display Fixture ID.....	57
dragging.....	29

## E

Edit	
Preferences .....	29, 42
Elapsed Lockout .....	51
end time .....	50
exhaust fan .....	25
Exit .....	41

## F

F2 .....	29, 42
F3 .....	57
F4 .....	57
F5 .....	54
F7 .....	54
F8 .....	43
firmware revision .....	60
fixture icon .....	23
Fixture Properties .....	58
flush.....	44, 53
flush overflow .....	26
FlushGuard.....	36, 53

<b>H</b>	
hot water .....	44
hours.....	50
<b>I</b>	
icon.....	20
initiate delay.....	10, 26, 45
Integration.....	75
<b>J</b>	
jump .....	39
<b>L</b>	
Level 1 .....	24
Level 2 .....	23
locked.....	10
Lockout .....	48
Log File.....	54
<b>M</b>	
Main Toolbar .....	30, 57
manual lockout.....	27
Menu .....	23, 30
minutes.....	50
mode	
networked.....	7
stand-alone .....	7, 9
Modified.....	40
mouse .....	60
<b>N</b>	
non-use.....	45
<b>O</b>	
Operator (Security Level) .....	67
overflow Reset .....	13
overflow sensor.....	39
Overuse .....	27
<b>P</b>	
Parent Layout.....	54
passwords.....	69
PgUp .....	54
PM.....	50
popup .....	38
pop-up menu .....	60
preferences .....	29
Preferences .....	42
<b>R</b>	
refresh .....	55
Refresh .....	54
reinitiate delay .....	10, 26, 45
Remote Activate.....	52
Remote Off.....	51
Remove .....	50
reset .....	39
Reset.....	48
reset fixture.....	39
right mouse button.....	61
<b>S</b>	
Save .....	40
scheduled lockout.....	27, 48, 49
Scheduled Permit.....	27, 48, 49
Scheduled Permit times .....	49
Security .....	74
Security Levels.....	67
Select All.....	29, 53
selected state.....	28
serial number .....	60
server .....	72, 74
shower .....	9, 25
silence alarm.....	39
simultaneous flushes .....	36
Single Pane.....	56
sound .....	33, 39
Split Combi .....	31, 32
Split Horizontal .....	56
Split Vertical .....	56
start time.....	50
status.....	26
Status Bar .....	21, 30
Clock Pane .....	22
Coordinate Pane .....	22
Information Pane .....	21
Level Pane .....	22
Manage Pane .....	22
Modified Pane .....	21
Supervisor (Security Level).....	67
<b>T</b>	
Time Outs (User Level).....	70
Toilet Overflow .....	39
toolbars.....	30
touch screen.....	24, 28, 29
<b>U</b>	
User levels.....	67
Users.....	43
<b>V</b>	
Valve Overuset.....	45
Valve Timing.....	43
View (Security Level) .....	67

**W**

water fountain.....25  
Water Overuse.....38

